

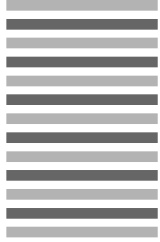



The specifications on each item can be amended without any prenotice to improve aperformance.  
The specifications on each item can be different form actual specification.

YPC



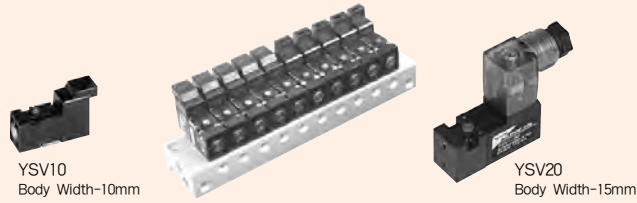

Products Item List  
**CONTENTS**

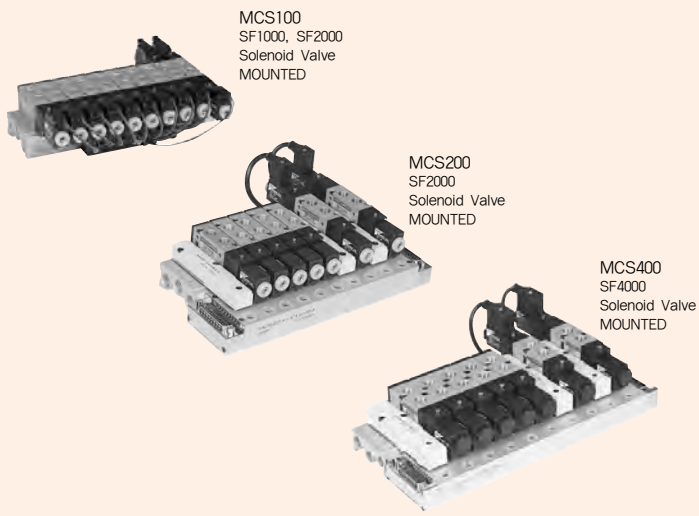
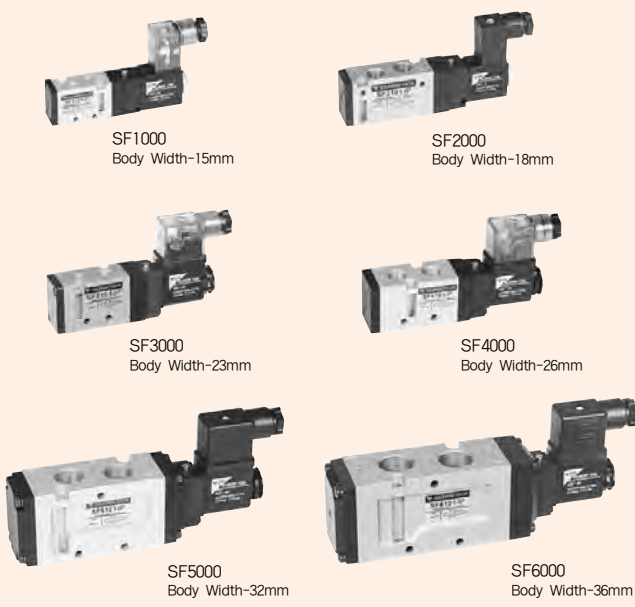
CHAPTER 01

ITEM	SERIES	MODEL	PORT SIZE	PAGE
<b>YSV Series</b> 3/2 10mm Pico V/V 3/2 15mm Micro V/V	 <p>YSV10 Body Width-10mm</p> <p>YSV20 Body Width-15mm</p>	YSV10	P = 0.6 R = 0.8	10
		YSV20	P = 1.1 R = 1.5	12
<b>YSV Series</b> 3/2-NC, NO Staking Body Valve	 <p>YSV200 Thread/M5 × 0.8</p> <p>YSV300 Thread/1/8</p>	YSV200	M5	14
		YSV300	1/8	16
<b>MCS Series</b> Multi Connector System	 <p>MCS100 SF1000, SF2000 Solenoid Valve MOUNTED</p> <p>MCS200 SF2000 Solenoid Valve MOUNTED</p> <p>MCS400 SF4000 Solenoid Valve MOUNTED</p>	MCS100	SF1000,2000 Solenoid Valve MOUNTED	20
		MCS200	SF2000 Solenoid Valve MOUNTED	22
		MCS400	SF4000 Solenoid Valve MOUNTED	24
<b>SF (FLEXIBLE) Series</b> 5/2, 5/3, 3/2 Solenoid, Pneumatic Valve	 <p>SF1000 Body Width-15mm</p> <p>SF2000 Body Width-18mm</p> <p>SF3000 Body Width-23mm</p> <p>SF4000 Body Width-26mm</p> <p>SF5000 Body Width-32mm</p> <p>SF6000 Body Width-36mm</p>	SF1000	M5 × 0.8	28
		SF2000	1/8	30
		SF3000	1/8	32
		SF4000	1/4	34
		SF5000	3/8	36
		SF6000	1/2	38

CHAPTER 02

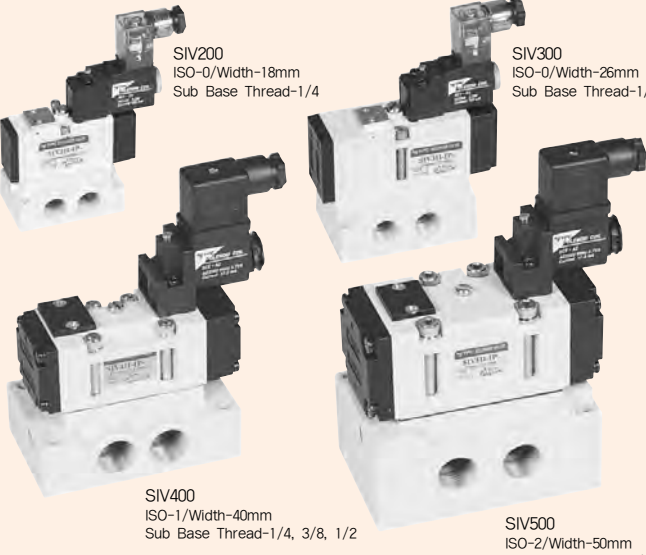
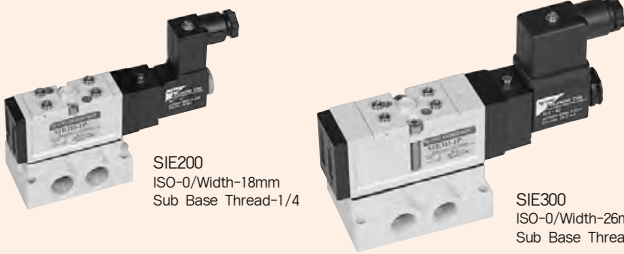
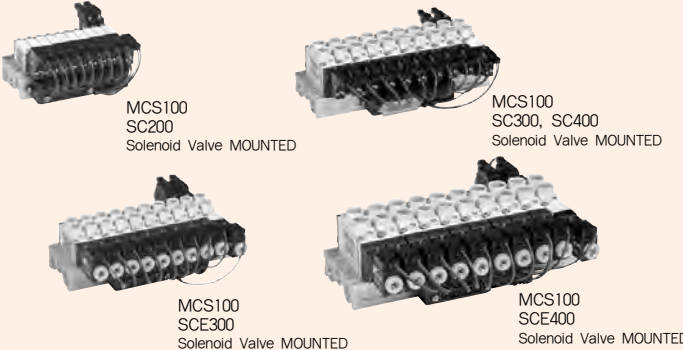
CHAPTER 03

ITEM	SERIES	MODEL	PORT SIZE	PAGE
<b>SIV (ISO) Series</b> 5/2, 5/3 Solenoid, Pneumatic Valve	 <p>SIV200 ISO-0/Width-18mm Sub Base Thread-1/4</p> <p>SIV300 ISO-0/Width-26mm Sub Base Thread-1/4</p> <p>SIV400 ISO-1/Width-40mm Sub Base Thread-1/4, 3/8, 1/2</p> <p>SIV500 ISO-2/Width-50mm Sub Base Thread-1/2, 3/4</p>	SIV200	ISO-0-18 Sub Base Thread -1/4	42
		SIV300	ISO-0-26 Sub Base Thread -1/4	44
		SIV400	ISO-1 Sub Base Thread -1/4, 3/8, 1/2	46
		SIV500	ISO-2 Sub Base Thread -1/2, 3/4	48
<b>SIE (ECONOMY) Series</b> 5/2, 5/3 Solenoid Pneumatic Valve	 <p>SIE200 ISO-0/Width-18mm Sub Base Thread-1/4</p> <p>SIE300 ISO-0/Width-26mm Sub Base Thread-1/4</p>	SIE200	ISO-0-18 Sub Base Thread -1/4	50
		SIE300	ISO-0-26 Sub Base Thread -1/4	52
<b>MCS Series</b> Multi Connector System	 <p>MCS100 SC200 Solenoid Valve MOUNTED</p> <p>MCS100 SC300, SC400 Solenoid Valve MOUNTED</p> <p>MCS100 SCE300 Solenoid Valve MOUNTED</p> <p>MCS100 SCE400 Solenoid Valve MOUNTED</p>	MCS100	SC200,300,400 Solenoid Valve MOUNTED	56
			SCE300,400 Solenoid Valve MOUNTED	58
<b>SC (COMPACT) Series</b> 5/2, 5/3, 3/2 Solenoid, Pneumatic Valve	 <p>SC200 Body Width-10mm</p> <p>SC300 Body Width-15mm</p> <p>SC400 Body Width-18mm</p> <p>SC260 Body Width-10mm</p> <p>SC360 Body Width-15mm</p> <p>SC460 Body Width-18mm</p>	SC200	M5, M3	62
		SC300	1/8, M5	64
		SC400	1/4, 1/8	66

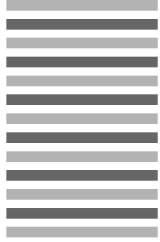

Products Item List  
**CONTENTS**





ITEM	SERIES	MODEL	PORT SIZE	PAGE
<b>SCE            (ECONOMY)            Series</b> 5/2, 5/3, 3/2 Solenoid, Pneumatic Valve	<p>SCE300 Body Width-15mm</p> <p>SCE400 Body Width-18mm</p> <p>SCE500 Body Width-26mm</p> <p>SCE360 Body Width-15mm</p> <p>SCE460 Body Width-18mm</p>	SCE300	M5, 1/8	68
		SCE400	1/8, 1/4	70
		SCE500	3/8	72
<b>SN Series</b> 5/2, 5/3 Namur Solenoid, Pneumatic Valve	<p>SN3000 Body Width-23mm</p> <p>SN4000 Body Width-30mm</p>	SN3000	1/4	76
		SN4000	1/4	78
<b>SOLENOID            Coil</b>	Width 15mm <p>SC1 SG1 SD1 SL1 SM1</p> Width 22mm <p>SC2 SG2 SD2</p>	SC1-A2, A1, D4 (AC220V, 110V, DC24V)	Width-15mm Width-22mm	80
		SC2-A2, A1, D4 (AC220V, 110V, DC24V)		
<b>DIN            CONNECTOR</b>	<p>CN1 CD1 CZ1 CN2 CD2 CZ2</p>	CN1 CN2	Width-15mm Width-22mm	82

CHAPTER 06

CHAPTER 07

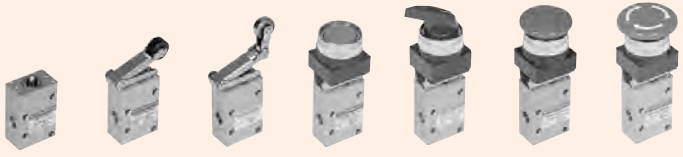
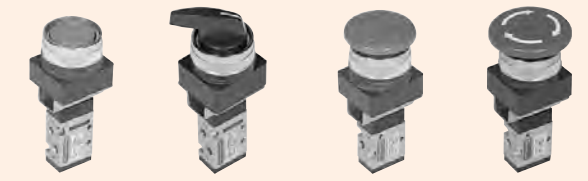
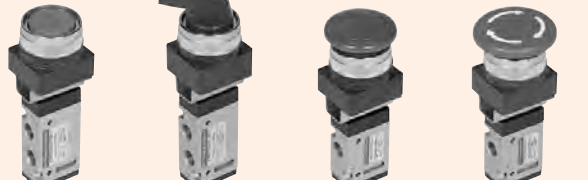
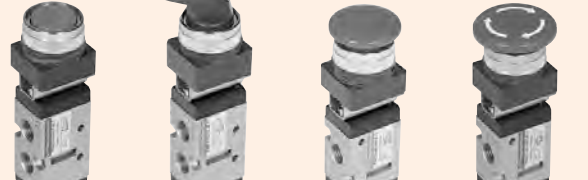

CHAPTER 08



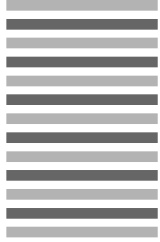

ITEM	SERIES	MODEL	PORT SIZE	PAGE
<b>YMV Series</b> 3/2 Mechanically Valve	 <p>                         YMV310-PU   YMV310-1RP   YMV310-2RB   YMV310-FP   YMV310-SL   YMV310-MS   YMV310-MT                     </p>	YMV310	1/8	86
		YMV410	1/4	
<b>PMEV (ECONOMY) Series</b> 5/2, 3/2 Panel Mounted Manually Valve	 <p>                         PMEV110-FP Body width-15mm Panel Hole-<math>\varnothing</math>25   PMEV110-SL   PMEV160-MS   PMEV160-MT                     </p>	PMEV110 PMEV160	M5×0.8	88
	 <p>                         PMEV210-FP Body width-18mm Panel Hole-<math>\varnothing</math>30   PMEV210-SL   PMEV260-MS   PMEV260-MT                     </p>	PMEV210 PMEV260	1/8	
	 <p>                         PMEV410-FP Body width-26mm Panel Hole-<math>\varnothing</math>30   PMEV410-SL   PMEV460-MS   PMEV460-MT                     </p>	PMEV410 PMEV460	1/4	
<b>RLV Series</b> 5/2, 3/2 Roller Lever Mechanical Valve	 <p>                         RLV110-PU Body width-15mm   RLV110-1RP   RLV160-PU   RLV160-2RB                     </p>	RLV110 RLV160	M5×0.8	90
	 <p>                         RLV210-PU Body width-18mm   RLV210-1RB   RLV260-PU   RLV260-2RP                     </p>	RLV210 RLV260	1/8	
	 <p>                         RLV410-PU Body width-26mm   RLV410-1RB   RLV460-PU   RLV460-2RP                     </p>	RLV410 RLV460	1/4	

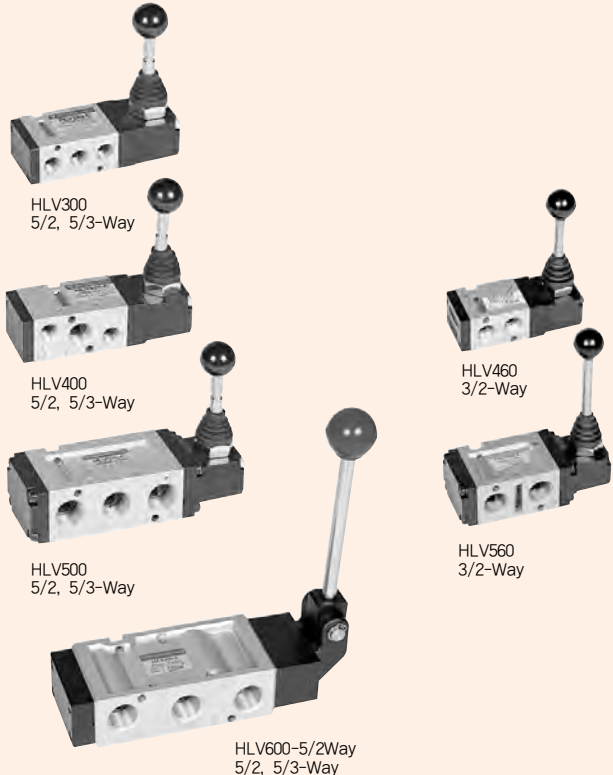

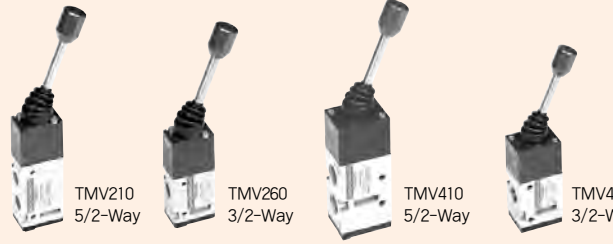
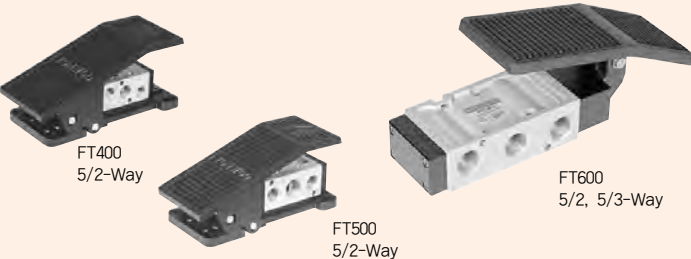
Products Item List  
**CONTENTS**

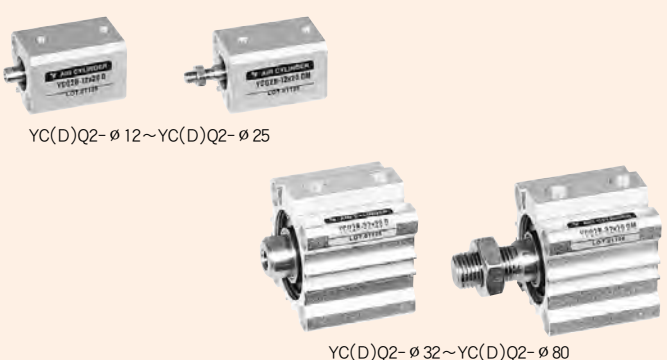
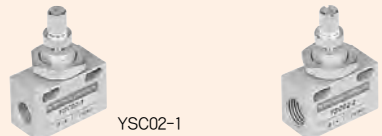
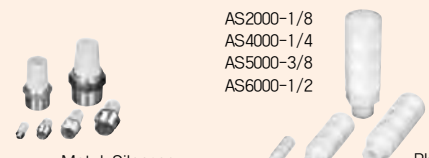
ITEM	SERIES	MODEL	PORT SIZE	PAGE
<b>HLV Series</b> 5/2, 5/3, 3/2 Hand Lever Manually Valve	 <p>HLV300 5/2, 5/3-Way</p> <p>HLV400 5/2, 5/3-Way</p> <p>HLV500 5/2, 5/3-Way</p> <p>HLV600-5/2Way 5/2, 5/3-Way</p> <p>HLV460 3/2-Way</p> <p>HLV560 3/2-Way</p>	HLV310-S HLV320-D HLV330-S,D HLV340-S,D HLV350-S,D HLV410-S HLV420-D HLV430-S,D HLV440-S,D HLV450-S,D HLV460-S,D HLV510-S HLV520-D HLV530-S,D HLV540-S,D HLV550-S,D HLV560-S,D HLV610-S HLV620-D HLV630-S,D HLV640-S,D HLV650-S,D	1/8 1/4 3/8 1/2	92
<b>KMV Series</b> 5/2, 3/2 Knob Push/Pull Manually Valve	 <p>KMV310 5/2-Way</p> <p>KMV410 5/2-Way</p> <p>KMV460 3/2-Way</p>	KMV310-S KMV310-D KMV310-DA KMV410-S,D,DA KMV460-S,D,DA	1/8 1/4	94
<b>TMV Series</b> 5/2, 3/2 Knob Push/Pull Manually Valve	 <p>TMV210 5/2-Way</p> <p>TMV260 3/2-Way</p> <p>TMV410 5/2-Way</p> <p>TMV460 3/2-Way</p>	TMV210 TMV260 TMV410 TMV460	1/8 1/4	96
<b>FT Series</b> 5/2, 5/3 Foot Treadle Manually Valve	 <p>FT400 5/2-Way</p> <p>FT500 5/2-Way</p> <p>FT600 5/2, 5/3-Way</p>	FT410-S FT510-S FT610-S FT620-D FT630-S,D FT640-S,D FT650-S,D	1/4 3/8 1/2	98

ITEM	SERIES	MODEL	PORT SIZE	PAGE
Compact Cylinder	 <p>YC(D)Q2-ø 12~YC(D)Q2-ø 25</p> <p>YC(D)Q2-ø 32~YC(D)Q2-ø 80</p>	YC[D]Q2-12	M5×0.8	102
		YC[D]Q2-16	M5×0.8	
		YC[D]Q2-20	M5×0.8	
		YC[D]Q2-25	M5×0.8	
		YC[D]Q2-32	1/8	
		YC[D]Q2-40	1/8	
		YC[D]Q2-50	1/4	
		YC[D]Q2-63	1/4	
	YC[D]Q2-80	3/8		
Speed Controller	 <p>YSC02-1</p> <p>YSC02-2</p>	YSC02-1	1/8	104
		YSC02-2	1/4	
Air Silencer	 <p>Metal Silencer</p> <p>Plastic Silencer</p>	ASS (Metal)	M5~PT1/2	106
		AS (Plastic)	PT1/8~PT1/2	
Air Hydro Converter	 <p>YCT63</p> <p>YCT100</p> <p>YCT160</p>	YCT63	Air Port-3/8 Oil Port-3/4	108
		YCT100	Air Port-1/2 Oil Port-1	
		YCT160	Air Port-3/4 Oil Port-1¼	
Booster Cylinder	 <p>YNBH3-40(11:1) YNBH3-60(25:1)</p> <p>YNPH3-40(11:1) YNPH3-60(25:1)</p>	YNBH3-40 (11:1) YNBH3-60 (25:1)	Air Port-3/8 Oil Port-1/2	110
		YNPH3-40 (11:1) YNPH3-60 (25:1)	Air Port-3/8 Oil Port-1/2	

# REFERENCE MATERIALS

The surface of earth is covered with air layer, which consists of nitrogen(78Vo 1%), oxygen(21Vo 1%) and small amount of CO<sub>2</sub>, AR, H<sub>2</sub>, Ne, Kt and Xe. To understand air movement and the law of nature, various physical terms as follow should be utilized. For better mutual understanding, scientist in most countries come to same unit system, called SI unit. Following are the relation between generally used engineering terms and new SI unit. In defining aerology, following term and words are required.

## BASIC UNITS

Unit	Sign	Eng. unit	SI unit
Length	l	m	m
Mass	m	$\frac{kp.s^2}{m}$	kg
Time	t	Sec.	Sec.
Temp.	T	Degress Celsius(°C)	Kelvin(K)
Electric current	I	Ampere(A)	Ampere(A)
Intensity light	I		Candela(cd)
	n		Mole(mol)

## DERIVED UNITS

Unit	Sign	Eng. unit	SI unit
Force	F	kP	Newton(N) $1N = \frac{1kg.m}{S^2}$
Area	A	m <sup>2</sup>	m <sup>2</sup>
Volume	V	m <sup>3</sup>	m <sup>3</sup>
Flux	V(Q)	m <sup>2</sup> /S	m <sup>2</sup> /S
Pressure	P	(Kp/cm <sup>2</sup> )	Pascal(Pa) Bar(bar) $1Pa = \frac{1N}{m^2}$ 1bar = 10 <sup>5</sup> Pa = 100kPa(10 <sup>2</sup> kPa) = 14.5psi

## CONVERSION TABLE OF PRESURE UNITS

No.	Pa	bar	kgf/cm <sup>2</sup>	atm	mmH <sub>2</sub> O	mmHg Torr	psi
1	1	1 × 10 <sup>-5</sup>	1.01972 × 10 <sup>-5</sup>	9.86923 × 10 <sup>-6</sup>	1.01972 × 10 <sup>-4</sup>	7.50062 × 10 <sup>-3</sup>	1.45038 × 10 <sup>-4</sup>
2	1 × 10 <sup>5</sup>	1	1.01972	9.86923 × 10 <sup>-4</sup>	1.01972 × 10 <sup>4</sup>	7.50062 × 10 <sup>2</sup>	1.45038 × 10 <sup>4</sup>
3	9.80665 × 10 <sup>4</sup>	9.80665 × 10 <sup>-4</sup>	1	9.67841 × 10 <sup>-4</sup>	1 × 10 <sup>4</sup>	7.3559 × 10 <sup>2</sup>	1.42234 × 10 <sup>4</sup>
4	1.01325 × 10 <sup>5</sup>	1.01325	1.03323	1	1.03323 × 10 <sup>4</sup>	7.60 × 10 <sup>2</sup>	1.46960 × 10 <sup>4</sup>
5	9.80665	9.80665 × 10 <sup>-5</sup>	1 × 10 <sup>-4</sup>	9.67841 × 10 <sup>-5</sup>	1	7.3559 × 10 <sup>-2</sup>	1.42234 × 10 <sup>-3</sup>
6	1.33322 × 10 <sup>2</sup>	1.33322 × 10 <sup>-3</sup>	1.35951 × 10 <sup>-3</sup>	1.31579 × 10 <sup>-3</sup>	1.35951 × 10	1	1.93368 × 10 <sup>-2</sup>
7	6.89473 × 10 <sup>3</sup>	6.89473 × 10 <sup>-2</sup>	7.03065 × 10 <sup>-2</sup>	6.80457 × 10 <sup>-2</sup>	7.03067 × 10 <sup>2</sup>	5.17147 × 10	1

## DIAGRAM FOR THE LAW OF Ω

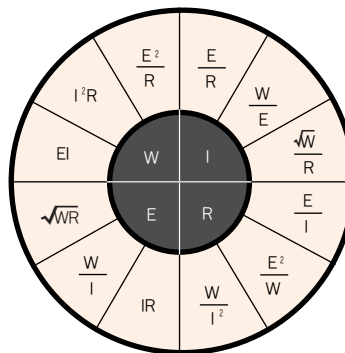

- I = Electric Current (A)
- E = Voltage (V)
- R = Resistance (Ω)
- W = Power consumption (w)

## ALLOWABLE TEMPERATURE ACCORDING TO THE TYPE OF INSULATOR

Insulation Type	Temperature rising value (°C)	Max, allowable temperature (°C)
Y Type *	below 50	above 90
A Type	below 65	above 105
E Type	below 80	above 120
B Type	below 90	above 130
F Type	below 115	above 155
H Type	below 140	above 180
C Type *	below 140	above 180

\* Theoretical Specifications

## CONSUMPTION ELECTRIC POWER

### AC Solenoid

electric power(VA) = Voltage(V) × electric current(A)

Consumption electric power(W) =

Voltage(V) × electric current(A) × COS θ

### DC Solenoid

Consumption electric power(W) = Voltage(V) × electric current (A)

# GUIDELINES FOR SAFELY USING SOLENOID VALVES

※Please carefully read prior to using the valves.



## DANGER

Failure to follow may result in death or serious personal injury.



## WARNING

Failure to follow may result in personal injury.



## CAUTION

Failure to follow may result in personal injury or machinery equipment damage.

### WARNING

#### Design, specification, and usage of the compressed air system

- Only the qualified personnel should design, specify, and handle the compressed air system.
- Recommended working condition for each and every product shown in the catalog varies. Implement only the most suitable working condition prior to specifying the system for each product.
- Proper safety features should be installed and secured prior to operating any machinery equipment. The source of disassembling any machinery to avoid any personal injury.

### CAUTION

#### Preparatory factors to consider prior to using the valves

- Verify the accuracy of the specifications of the valves prior to the usage.
- Verify and check that the specifications of the valves are consistent with the requested or ordered specifications.
- Use compressed air to clean any metallic residues, cutting oil, or dust inside of the piping system.
- Distance between the actuator and the valve should be as minimal as possible. The piping distance longer than the minimal leads to inefficiency, waste of compressed air, and slower response time of the valve.
- Use zinc-plated steel tube when steel tubing is required.
- Select and connect the proper ports for accurate piping.  
P(1) : Compressed air input connection ports  
B(2), A(4) : Actuator connection ports  
R2(3), R1(5) : Residual air exhaust ports
- Any and all foreign materials of impurity must be removed at the points of connection or from the inside of valve prior to piping.
- When connecting fittings to the ports, apply Teflon tape to the fitting threads. The first 2 threads of fitting should be free of any Teflon tape. Any fragment or portion of Teflon tape entering the inside of valve will result in the improper operations of the valve.

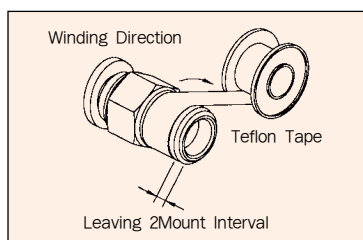

### WARNING

#### Installation environment for the valves

- Avoid any location where explosive, vibration, and impact factors are present.
- Maintain a sufficient space for a proper ventilation and for any needed repair work when installing valves.
- Use the valves within the allowable range of 5°C ~60°C of the ambient temperature and of the fluid material. In the valves when used under the low temperature working conditions.

### CAUTION

#### Usage conditions for valves

- Installing air filter and oiler prior to piping of valves leads to the extension of the product life.
- Use the purified and dried air only. The source of the compressed air that contains any chemicals, organic raw materials, salt, corrosive materials will render the valves defective and non-operational.
- Excessive air leakage from the compressed air system may reduce the product life of valve.

- Proper filtering system must be installed to prevent any substance of impurity from entering valves. Periodical monitoring or replacement of filters is strongly suggested.
- Use turbine oil type or class 2 (ISO VG #32) oil in order to extend the product life. Non-graded oil may be used.
- Use only the recommended oil type. Using non-recommended oil type may reduce the product life of valves due to damage caused by the shrinkage or enlargement of the valve packing. (Do not use spindle oil, machine oil, hydraulic oil, cooking oil, or anti-corrosion oil)
- Do not use the valves in the dusty working condition. If the dusty working condition is unavoidable, place a protective cover over the control unit and place the noise muffler or silencer at the exhaust ports of R2(3) and R1(5).
- Do not allow the valves to be on the stand-by or pause mode for an extended period of time. The stand-by or pause mode of valves should be used briefly and momentarily.
- Solenoid valves are not designed to be suddenly interrupted, stopped, or shut off. Consider and prepare other safety measurements before using the solenoid valves.

### WARNING

#### Electrical factors for the valves

- Allowable range of voltage variation should be within 10% of the recommended voltage for the proper operation of the valves. Any voltage exceeding more than 10% of the recommended voltage will result in the coil damage and the malfunctioning of the valves.
- Turning on or off of Alternate Current (AC) may result in surge current that may have problematic effect to the magnetic circuitry. It is recommended that an alternate plan is implemented to avoid such problematic effect.
- Continuous supply of electricity to the solenoid coil may result in increase of the surface temperature of the coil. In order to avoid the damage to the coil, please verify circuitry design before piping.
- Even if the source of electricity is completely disconnected, the operation of the valves may not come a complete stop due to a residual current in the magnetic circuitry. Reduce the magnitude of the leakage current on both sides by 20% of the rated voltage for AC supply current and by 10% of the rated voltage for DC supply current.

### CAUTION

#### Applicable torque force when piping valves

- Applying excessive torque force will damage the fitting threads when connection to the valves. Use the following guideline of torque force for each applicable port size.

Port size	Applicable Torque N.m(kgf/cm)
M5	2(20)
PT1/8	15(150)
PT1/4	20(200)
PT3/8	25(250)
PT1/2	34(340)
PT3/4	51(510)
PT1	69(690)
PT1 1/4	80(800)
PT1 1/2	85(850)
PT2	120(1200)

# YSV10

Direct Actuated  
10mm Pico Solenoid Valves

- 3/2- Direct Operation Type
- Manifold Mounting Type
- Orifice  $\varnothing$ 0.6mm

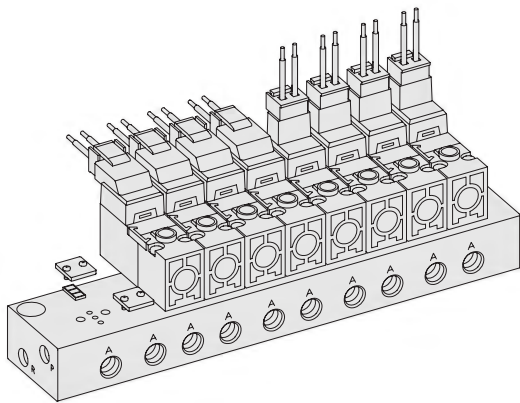
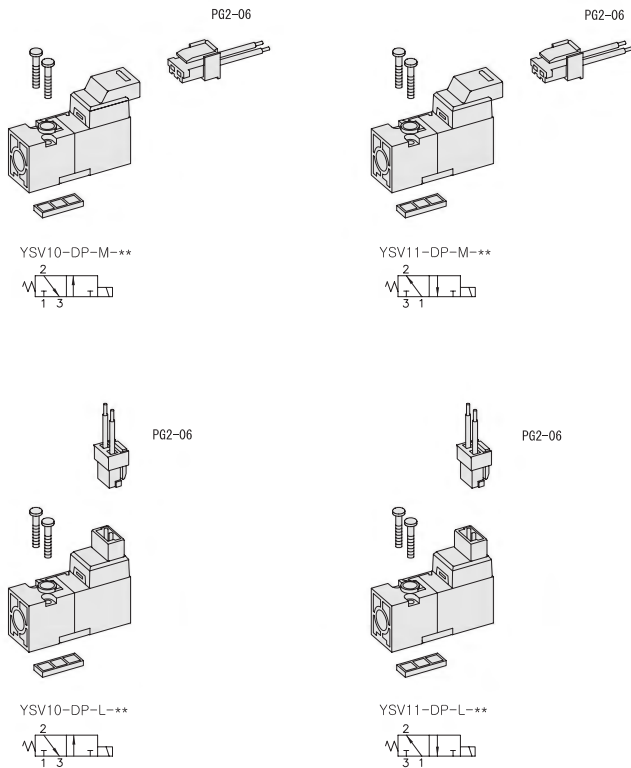

\*\* : Voltage Selection

## SPECIFICATION

ITEM	SERIES	YSV10	YSV11
FUNCTION		3/2-N.C	3/2-N.O
Fluids	Compressed Air & Inert Gases		
Pressure(bar)	1~8.0		
Orifice(mm)	P = $\varnothing$ 0.6, R = $\varnothing$ 0.7		
Ambient & Fluid Temp.	5~60°C (41~140°F)		
Response Time(5bar)	10ms or Less		
Max. Working Frequency	30c/sec		
Lubrication	Not Required(Use ISO VG32#)		
Manual Override	Push Button		
Coil Insulation Class	F-Class or Equivalent		
Permissible Voltage Variation	$\pm$ 10% of Rated Voltage		
Off Min. Residual Voltage	10% of Rated Voltage		
Power Consumption	0.65W(24V : 27.0mA / 12V : 54.0mA)		

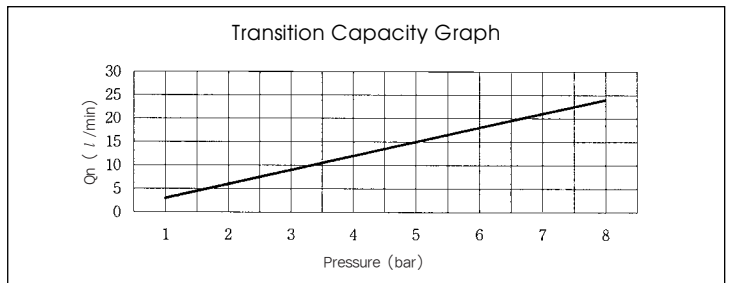

- The Material of Parts
- Pilot Parts : Glass Filled Nylon
  - Spring : Stainless
  - Seals : NBR
  - Armature : Stainless Steel
  - Indicator Cap : Polycarbonate

<p style="text-align: center;">Plug Connector With Clip</p> <p style="text-align: center;"><b>Ordering Code</b> PG2-06 ( L : 600mm) PG2-10 ( L : 1,000mm)</p>	<p style="text-align: center;">Blanking Plate (Material : STS304)</p> <p style="text-align: center;"><b>Ordering Code</b> YMF10 - BLK</p>
---	---

※ The specification on each item can be amended without any prenotice to improve a performance.  
※ The specification on each item can be different from actual specification.

## ORDERING NO.

**YSV1 0 - D P - L - D4**

Valve Series	Function	Pilot Source	Manual Operator	Solenoid Coil Type	Voltage
YSV1 : Solenoid Valve	0   3/2 Normally Closed Spring Return 1   3/2 Normally Open Spring Return	D   Direct Operated	P   Push Non-Locking	L   90 Degree Plug-in Wire Assembly With LED M   180 Degree Plug-in Wire Assembly With LED	D4   DC 24V D2   DC 12V

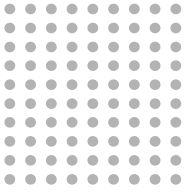

# Direct Solenoid Actuated Valves

# 10mm Pico

YSV10-DP-M-\*\*\*  
Normally Closed Type

YSV11-DP-M-\*\*\*  
Normally Open Type

YSV10-DP-L-\*\*\*  
Normally Closed Type

YSV11-DP-L-\*\*\*  
Normally Open Type

YMF10-M04

(Sealing Area)

### Manifold Block Ordering Code

YMF 10		-		2	
Symbol	Manifold Station				
YMF10	3 Way	02	2-Station		
		04	4-Station		
		06	6-Station		
		08	8-Station		
		10	10-Station		
		12	12-Station		
		14	14-Station		

### Blanking Plate Ordering Code

YMF10-BLK

Blanking Plate.  
(Material: STS304)

Manifold Gasket.  
(Material: NBR)

## YMF10 MANIFOLD BLOCK

(YSV10 Solenoid Valve Use)

3-PORT MANIFOLD BLOCK DIMENSION		n=STATION													
ITEM	n	2	3	4	5	6	7	8	9	10	11	12	13	14	
B		32.5	43.0	53.5	64.0	74.5	85.0	95.5	106.0	116.5	127.0	137.5	148.0	158.5	
A		40.5	51.0	61.5	72.0	82.5	93.0	103.5	114.0	124.5	135.0	145.5	156.0	166.5	

Normally Closed Type

Normally Open Type



# YSV20

Direct Actuated  
15mm Micro Solenoid Valves

- 3/2- Direct Operation Type
- Manifold Mounting Type
- Orifice  $\varnothing 1.1\text{mm}$

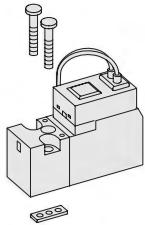

YSV20-DP-SD-\*\*\*  
M 1 2 3

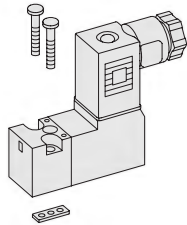

YSV20-DP-SC-CN1-\*\*\*  
M 1 2 3

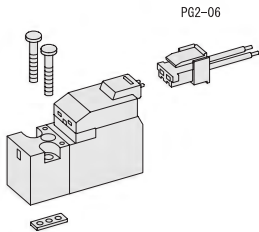

YSV20-DP-SM-\*\*\*  
M 1 2 3

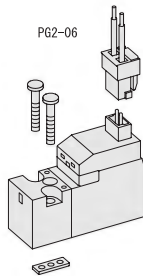

YSV20-DP-SL-\*\*\*  
M 1 2 3

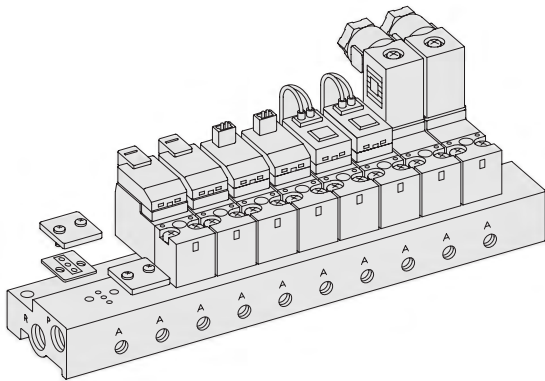

\*\* : Voltage Selection

## SPECIFICATION

ITEM	SERIES	FUNCTION
	YSV20	3/2-N.C
Fluids	Compressed Air & Inert Gases	
Pressure(bar)	0~8.0	
Orifice(mm)	P = $\varnothing 1.1$ , R = $\varnothing 1.5$	
Ambient & Fluid Temp.	5~60°C (41~140°F)	
Response Time(5bar)	20ms or Less	
Max. Working Frequency	10c/sec	
Lubrication	Not Required(Use ISO VG32 #)	
Manual Override	Push Button	
Coil Insulation Class	F-Class or Equivalent	
Permissible Voltage Variation	$\pm 10\%$ of Rated Voltage	
Off Min. Residual Voltage	AC:20% or Less / DC:10% or Less	
Power Consumption	AC:3.5VA(60Hz) / DC:2.5W	

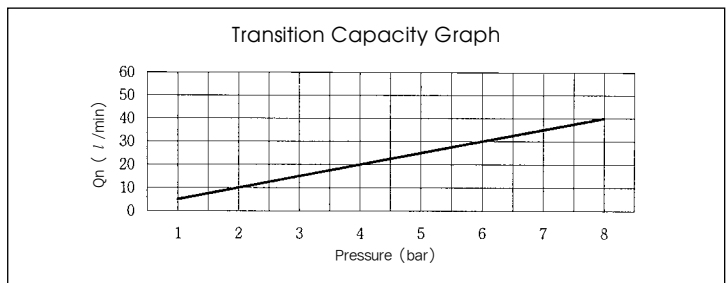

- The Material of Parts
- Pilot Parts : Glass Filled Nylon
  - Spring : Stainless
  - Seals : NBR
  - Armature : Stainless Steel
  - Indicator Cap : Polycarbonate
  - Lead Wire : AWG-no.24
  - Lead Wire Packing : Viton

Plug Connector With Clip

**Ordering Code**  
PG2-06 ( L : 600mm)  
PG2-10 ( L : 1,000mm)

Blanking Plate (Material : STS304)

**Ordering Code**  
YMF20 - BLK

\* The specification on each item can be amended without any prenotice to improve a performance.  
\* The specification on each item can be different from actual specification.

## ORDERING NO.

**YSV2 0 - D P - SC - CN1 - D4**

Valve Series	Function		Pilot Source		Manual Operator		Solenoid Coil Type		Connector Type		Voltage	
YSV2 : Solenoid Valve	0	3/2 Normally Closed Spring Return	D	Direct Operated	P	Push Non-Locking	0	None	CN1	Normal Connector	0	None
							SC	3 Pin Connector Coil	CD1	Connector With LED	A2	AC 220V
							SG	Grommet /Flying Leads	CZ1	Connector With LED & Surge Suppressor	A1	AC 110V
							SD	Grommet /Flying Leads With LED			D4	DC 24V
							SL	90 Degree Plug-in Wire Assembly with LED			D2	DC 12V
							SM	180 Degree Plug-in Wire Assembly with LED				

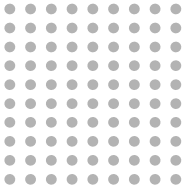

# Direct Solenoid Actuated Valves

# 15mm Micro

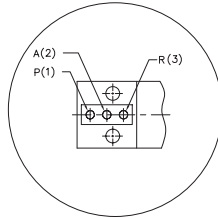
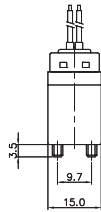
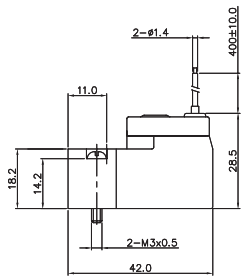
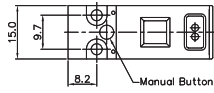

Normally Closed Type

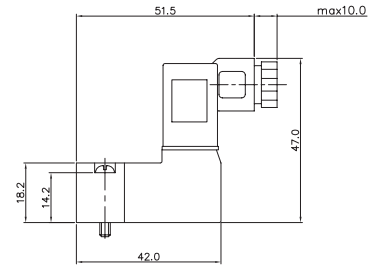

YSV20-DP-SC-CN1-\*\*\*  
Normally Closed

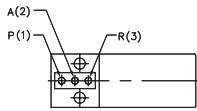
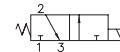

YSV20-DP-SD-\*\*\*  
Normally Closed

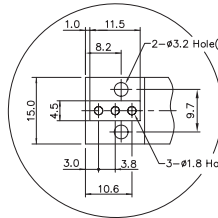
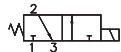

Sealing Area

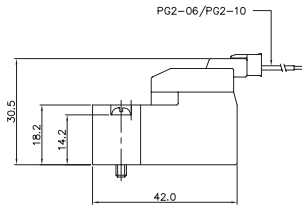

YSV20-DP-SM-\*\*\*  
Normally Closed

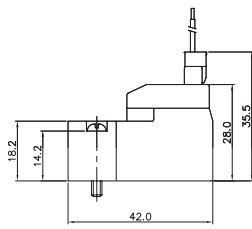
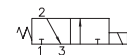

YSV20-DP-SL-\*\*\*  
Normally Closed

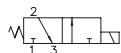

### Manifold Block Ordering Code

YMF 20		-	2
Symbol	Manifold Station		
YMF20	3 Way	02	2-Station
		04	4-Station
		06	6-Station
		08	8-Station
		10	10-Station
		12	12-Station
		14	14-Station

### Blanking Plate Ordering Code

YMF20-BLK

Blanking Plate.  
(Material: STS304)

Manifold Plate.  
(Material: STS304)

Manifold Gasket.  
(Material: NBR)

## YMF20 MANIFOLD BLOCK

(YSV20 Solenoid Valve Use)

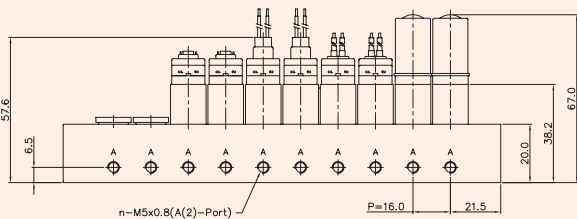
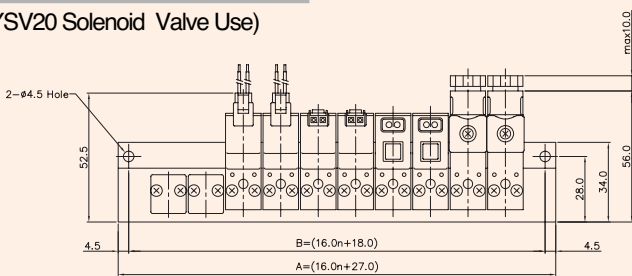

3-PORT MANIFOLD BLOCK DIMENSION		n=STATION					
ITEM	2	4	6	8	10	12	14
B	50.0	82.0	114.0	146.0	178.0	210.0	242.0
A	59.0	91.0	123.0	155.0	187.0	219.0	251.0

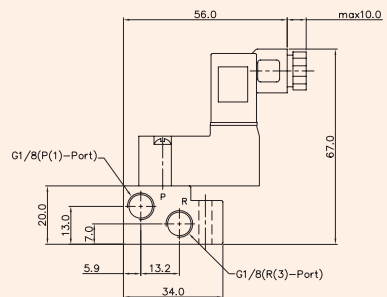

# YSV200. M5

Direct Actuated  
Staking Body Valves

- 3/2- Direct Operation Type
- High Durability
- Orifice  $\varnothing$  1.1mm

## SPECIFICATION

ITEM	FUNCTION	YSV211	YSV221
		3/2-N.C	3/2-N.O
Fluids		Compressed Air & Inert Gases	
Pressure(bar)		0~8.0	
Orifice(mm)		P = $\varnothing$ 1.1, R = $\varnothing$ 1.2	P = $\varnothing$ 1.2, R = $\varnothing$ 1.1
Ambient & Fluid Temp.		5~60°C (41~140°F)	
Response Time(5bar)		20ms or Less	
Max. Working Frequency		8c/sec	
Lubrication		Not Required(Use ISO VG32 #)	
Manual Override		Push Button(Standard), Lever Lock(Optional)	
Coil Insulation Class		F-Class or Equivalent	
Permissible Voltage Variation		$\pm$ 10% of Rated Voltage	
Off Min. Residual Voltage		AC:20% or Less / DC:10% or Less	
Power Consumption		AC:3.5VA(60Hz) / DC:2.5W	

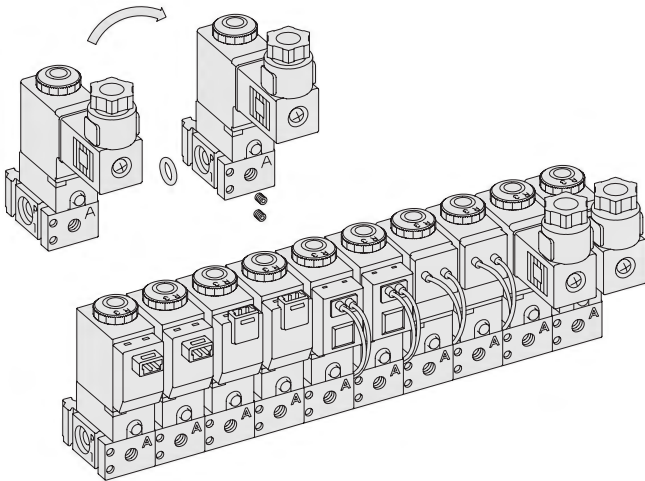
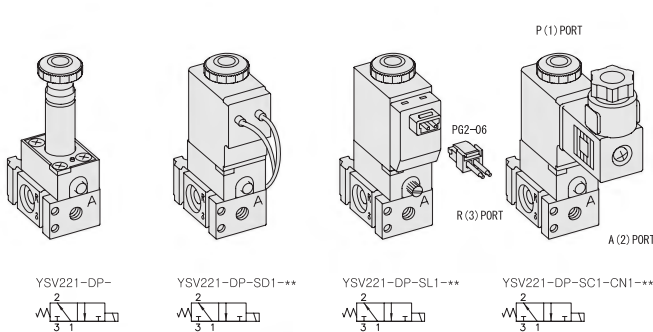
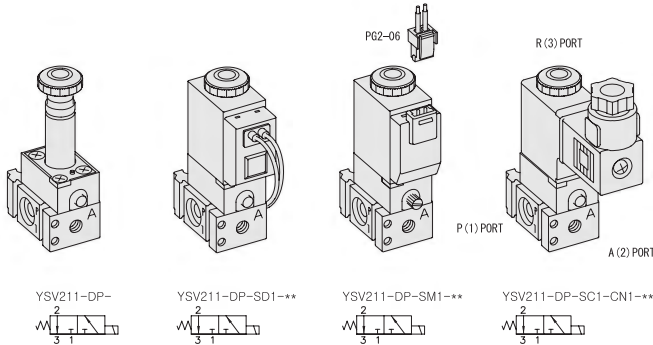

\*\* : Voltage Selection (see page 80)

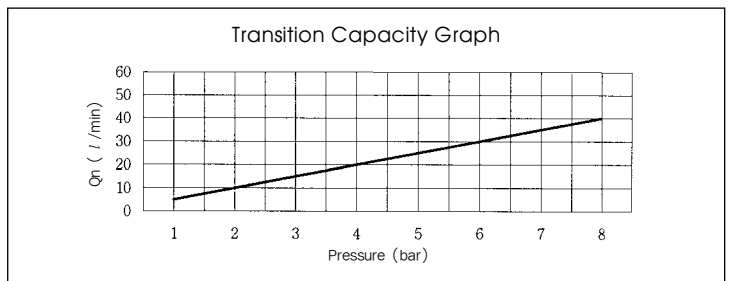

### The Material of Parts

- Valve Body : Aluminium
- Pilot Parts : Glass Filled Nylon
- Pilot Plate : Zinc Pressure Die-Cast
- Spring : Stainless
- Seals : NBR
- Armature : Stainless Steel
- Armature Seals : Viton

### Plug Connector With Clip

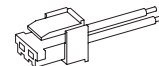

#### Ordering Code

PG2-06 ( L : 600mm)  
PG2-10 ( L : 1,000mm)

\* The specification on each item can be amended without any prenotice to improve a performance.  
\* The specification on each item can be different from actual specification.

## ORDERING NO.

**YSV2 1 1 - D P - SC1 - CN1 - A2**

Valve Series	Function	Port Size & Thread	Pilot Source	Manual Operator	Solenoid Coil Type	Connector Type	Voltage
YSV2 : Solenoid Valve	1	3/2 Normally Closed Spring Return	1 M5x0.8	D Direct Operated	P Push Non-Locking Override	0 None	0 None
	2	3/2 Normally Open Spring Return	2 10-32 UNF	L LeverLocking Override	SC1 3 Pin Connector Coil SG1 Grommet/Flying Leads SD1 Grommet/Flying Leads With LED SL1 90 Degree Plug-in Wire Assembly with LED SM1 180 Degree Plug-in Wire Assembly with LED	CN1 Normal Connector CD1 Connector With LED CZ1 Connector With LED & Surge Suppressor	A2 AC 220V A1 AC 110V A4 AC 24V D4 DC 24V D2 DC 12V

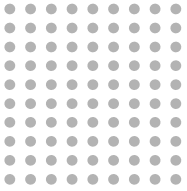

# Direct Solenoid Actuated Valves

Port Thread **M5 × 0.8**

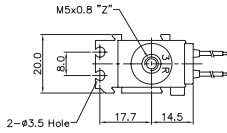

PORT	TYPE	N.C	N.O
X	P(1)	R(3)	
Y	A(2)	A(2)	
Z	R(3)	P(1)	

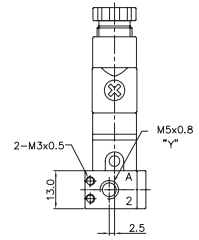
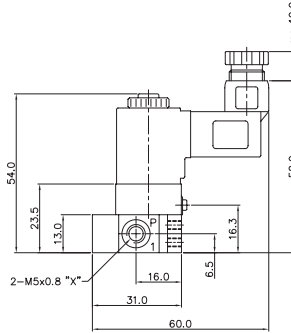
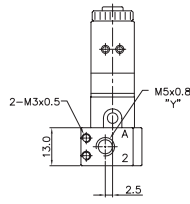
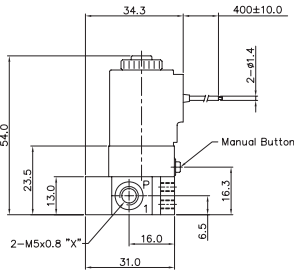
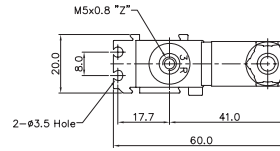

YSV211-DP-SG1-\*\*\*  
Normally Closed

YSV221-DP-SG1-\*\*\*  
Normally Open

YSV211-DP-SC1-CN1-\*\*\*  
Normally Closed

YSV221-DP-SC1-CN1-\*\*\*  
Normally Open

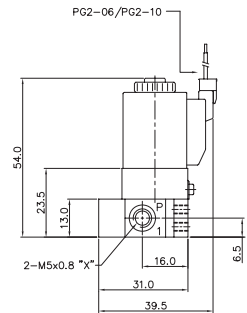
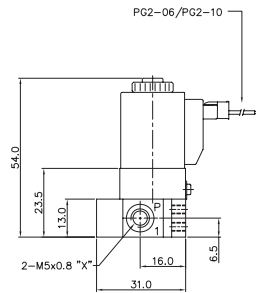
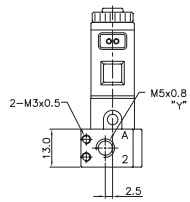
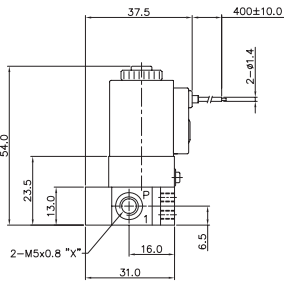
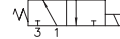
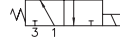
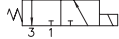

YSV211-DP-SD1-\*\*\*  
Normally Closed

YSV221-DP-SD1-\*\*\*  
Normally Open

YSV211-DP-SL1-\*\*\*  
Normally Closed

YSV221-DP-SL1-\*\*\*  
Normally Open

YSV211-DP-SM1-\*\*\*  
Normally Closed

YSV221-DP-SM1-\*\*\*  
Normally Open

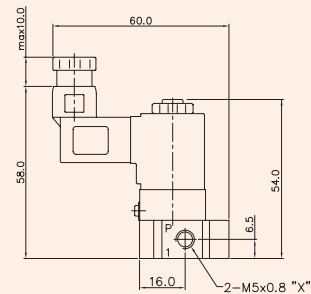
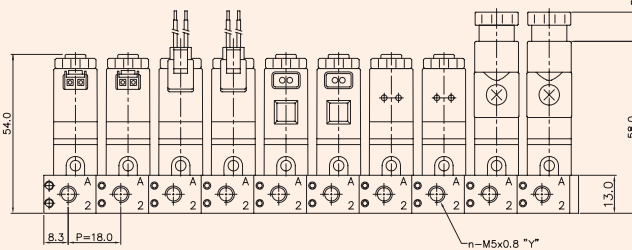
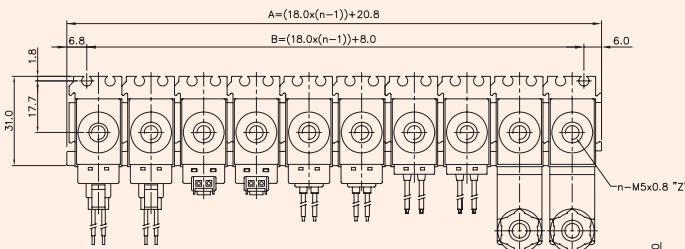
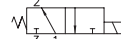
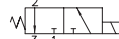
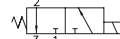
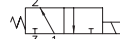
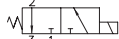

**A, B = DIMENSIONS**

n = STATION

ITEM	n	2	3	4	5	6	7	8	9	10
A		38.8	56.8	74.8	92.8	110.8	128.8	146.8	164.8	182.8
B		26.0	44.0	62.0	80.0	98.0	116.0	134.0	152.0	170.0

# YSV300. 1/8

Direct Actuated  
Staking Body Valves

- 3/2- Direct Operation Type
- High Durability
- Orifice  $\varnothing$  1.5mm

## SPECIFICATION

ITEM	SERIES	YSV311	YSV321
	FUNCTION	3/2-N.C	3/2-N.O
Fluids	Compressed Air & Inert Gases		
Pressure(bar)	0~8.0		
Orifice(mm)	P = $\varnothing$ 1.5, R = $\varnothing$ 1.5		P = $\varnothing$ 1.5, R = $\varnothing$ 1.5
Ambient & Fluid Temp.	5~60°C (41~140°F)		
Response Time(5bar)	20ms or Less		
Max. Working Frequency	8c/sec		
Lubrication	Not Required(Use ISO VG32 #)		
Manual Override	Push Button(Standard), Lever Lock(Optional)		
Coil Insulation Class	F-Class or Equivalent		
Permissible Voltage Variation	$\pm$ 10% of Rated Voltage		
Off Min. Residual Voltage	AC:20% or Less / DC:10% or Less		
Power Consumption	AC:3.5VA(60Hz) / DC:2.5W		

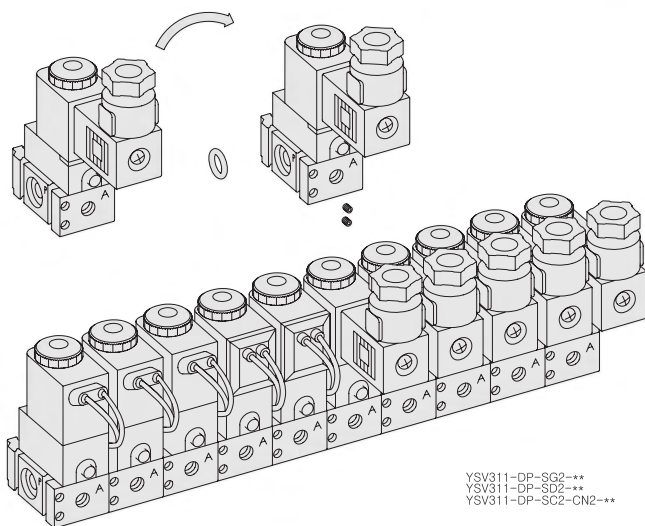
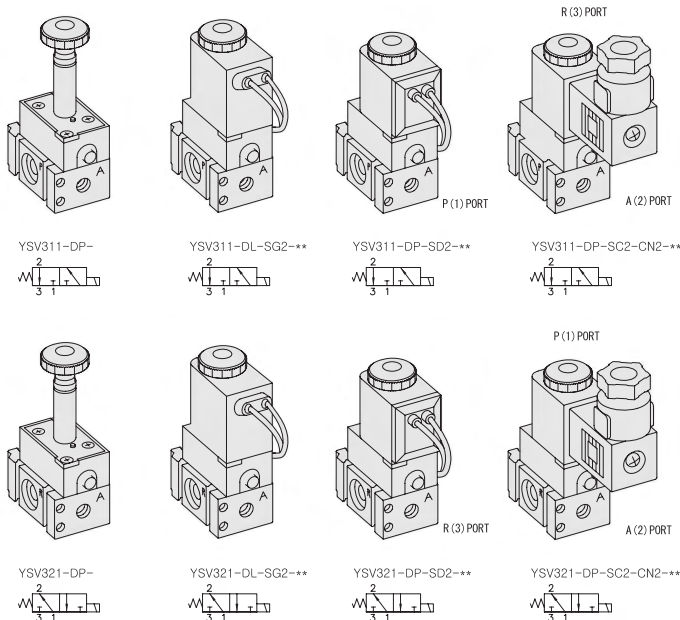

\*\* : Voltage Selection (see page 80)

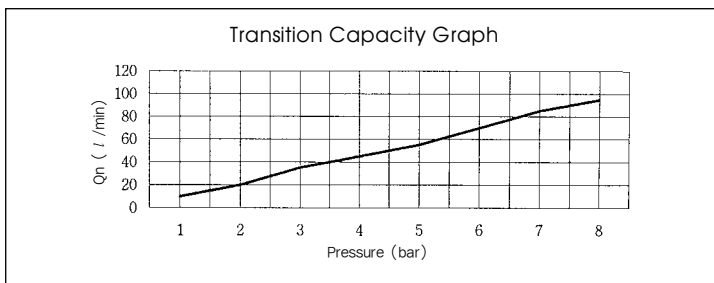

### The Material of Parts

■ Valve Body : Aluminium	■ Armature : Stainless Steel
■ Pilot Parts : Glass Filled Nylon	■ Armature Seals : Viton
■ Pilot Plate : Zinc Pressure Die-Cast	
■ Spring : Stainless	
■ Seals : NBR	

\* The specification on each item can be amended without any prenotice to improve a performance.  
\* The specification on each item can be different from actual specification.

## ORDERING NO.

**YSV3 1 1 - D P - SC2 - CN2 - A2**

Valve Series	Function	Port Size & Thread	Pilot Source	Manual Operator	Solenoid Coil Type	Connector Type	Voltage
YSV3 : Solenoid Valve	1	1 G 1/8	D Direct Operated	P Push Non-Locking Override	0 None	0 None	0 None
	2	2 NPT 1/8		L Lever Locking Override	SC2 3 Pin Connector Coil	CN2 Normal Connector	A2 AC 220V
					SG2 Grommet/Flying Leads	CD2 Connector With LED	A1 AC 110V
					SD2 Grommet/Flying Leads With LED	CZ2 Connector With LED & Surge Suppressor	A4 AC 24V D4 DC 24V D2 DC 12V

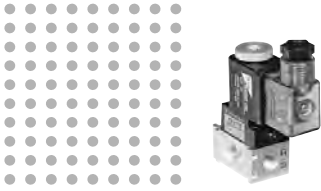

# Direct Solenoid Actuated Valves

Port Thread **1/8**

PORT	TYPE	N.C	N.O
X	P(1)	R(3)	
Y	A(2)	A(2)	
Z	R(3)	P(1)	

**YSV310-DP-SD2-\*\*\***  
 Normally Closed

**YSV320-DP-SD2-\*\*\***  
 Normally Open

**YSV310-DP-SG2-\*\*\***  
 Normally Closed

**YSV320-DP-SG2-\*\*\***  
 Normally Open

**YSV310-DP-SC2-CN2-\*\*\***  
 Normally Closed

**YSV320-DP-SC2-CN2-\*\*\***  
 Normally Open

$A = (24.8n + 4.0)$   
 $B = (24.8n - 11.2)$

$n = \text{STATION}$

ITEM	n	2	3	4	5	6	7	8	9	10
A		53.6	78.4	103.2	128.0	152.8	177.6	202.4	227.2	252.0
B		38.4	63.2	88.0	112.8	137.6	162.4	187.2	212.0	236.8





# MCS Series

## Multi Connector System (SF Series Solenoid Valve Mounted)

### CHAPTER 02



MCS100  
SF1000, SF2000  
Solenoid Valve  
MOUNTED

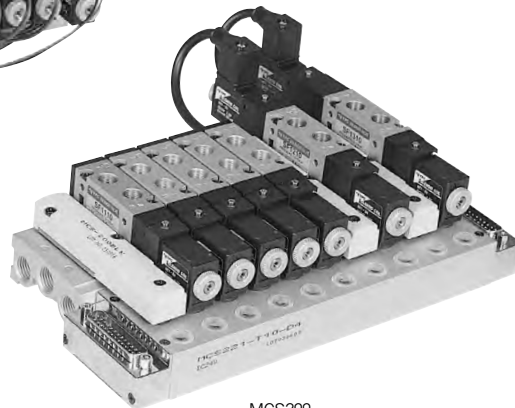

MCS200  
SF2000  
Solenoid Valve  
MOUNTED

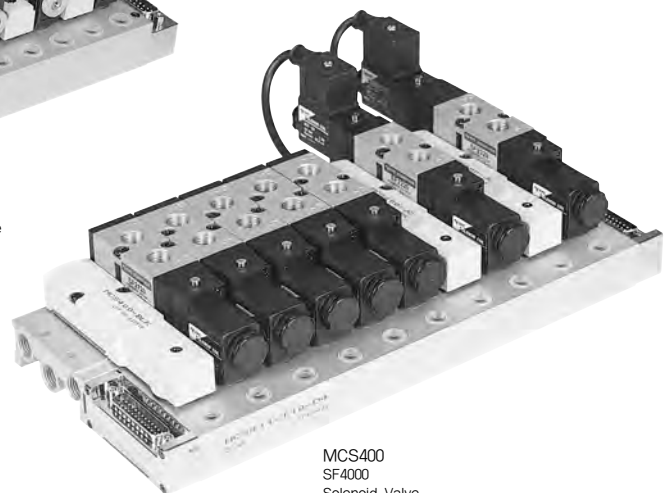

MCS400  
SF4000  
Solenoid Valve  
MOUNTED

- MCS100
- MCS200
- MCS400

# MCS100

Multi Connector System

SF1000, SF2000 Solenoid Valve MOUNTED

- DC 24V/ DC 12V
- 25Pin D-Sub Connector
- Simple Electric Wire System

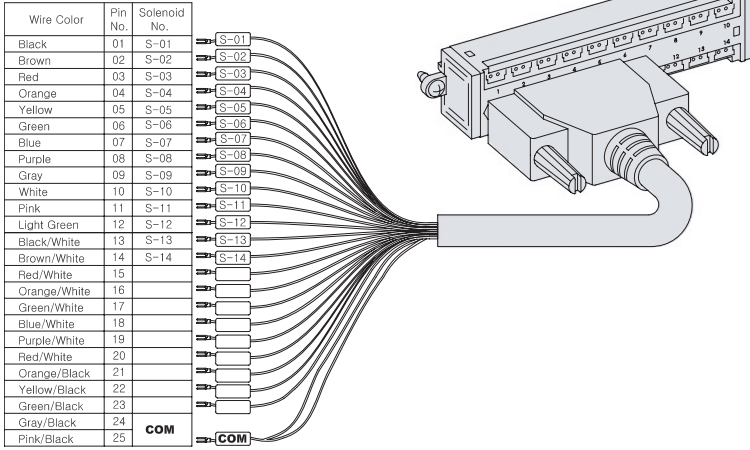

Terminal Box  
MCS100-T14-D4

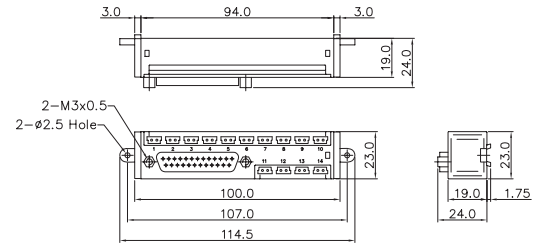

D-Sub Connector Pin No.

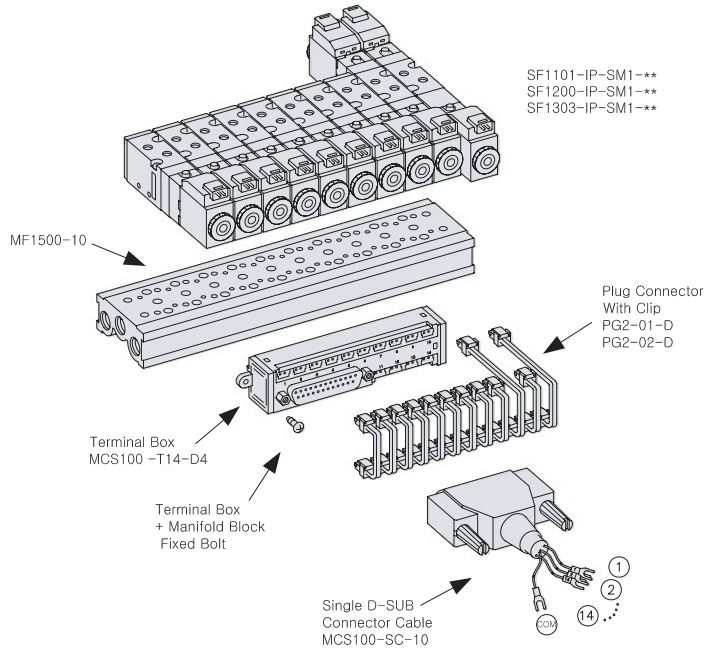
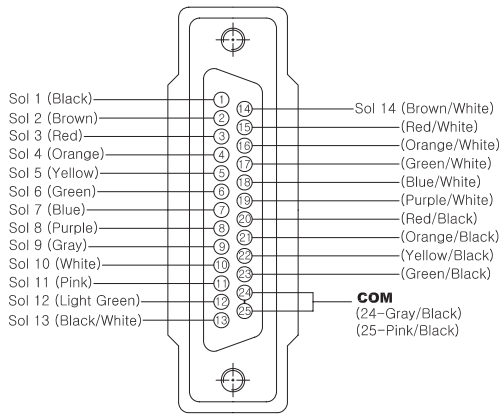

<p>Terminal Box</p> <p>Ordering Code MCS100-T14-**</p>	<p>Plug Connector With Clip</p> <p>Ordering Code PG2-01-D (100mm)</p>	<p>Single D-Sub Connector Cable IP40</p> <p>Ordering Code MCS100-SC-10 (1m)</p>
--	---	---

## ORDERING NO.

**MCS1 0 0 - T14 - D4**

Series	Function	D-Sub Connector	Multipole Wireway Box	Voltage
MCS1 : Multi Connector Solenoid Valve Mounted	0   Single Module	0   25 Pin D-Sub Connector	T14   14 Station	0   None D4   DC 24V D2   DC 12V

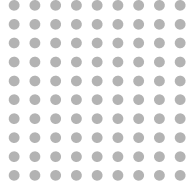

# Multi Connector System

# Solenoid Valve Mounted

## SF1000 Series Mounted

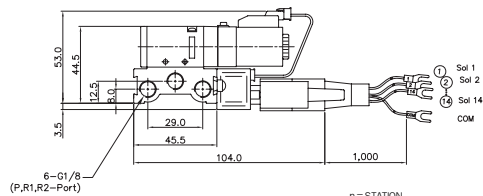
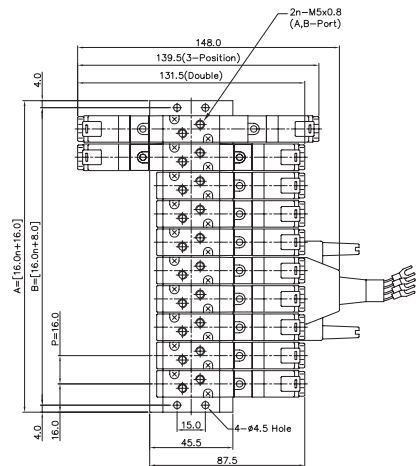

n = STATION

ITEM	n	8	10	12	14
B		136.0	168.0	200.0	232.0
A		144.0	176.0	208.0	240.0

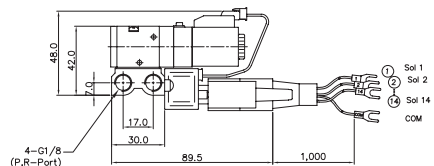
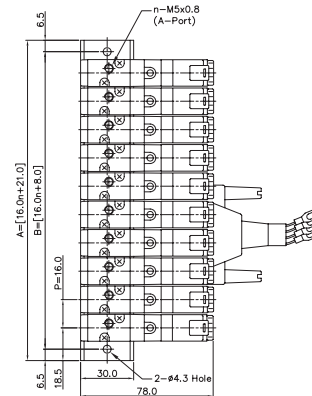

n = STATION

ITEM	n	8	10	12	14
B		136.0	168.0	200.0	232.0
A		149.0	181.0	213.0	245.0

## SF2000 Series Mounted

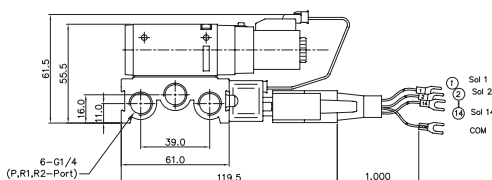
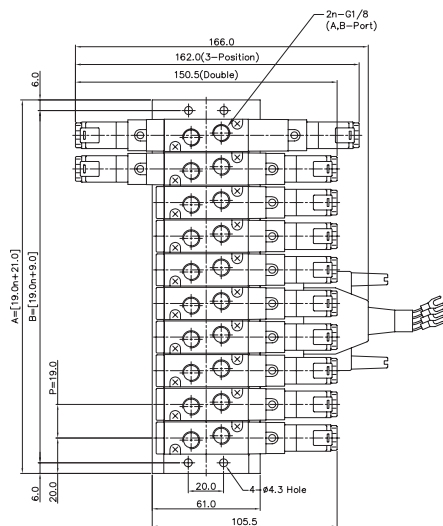

n = STATION

ITEM	n	8	10	12	14
B		161.0	199.0	237.0	275.0
A		173.0	211.0	249.0	287.0

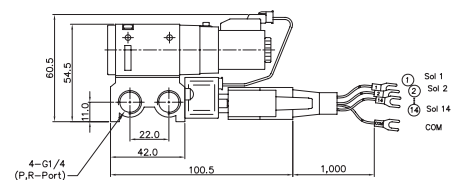
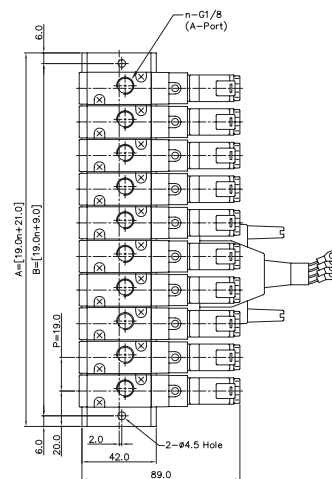

n = STATION

ITEM	n	8	10	12	14
B		161.0	199.0	237.0	275.0
A		173.0	211.0	249.0	287.0

# MCS200

Multi Connector System  
SF2000 Solenoid Valve MOUNTED

- DC 24V / DC 12V
- 25Pin D-Sub Connector
- Simple Electric Wire System

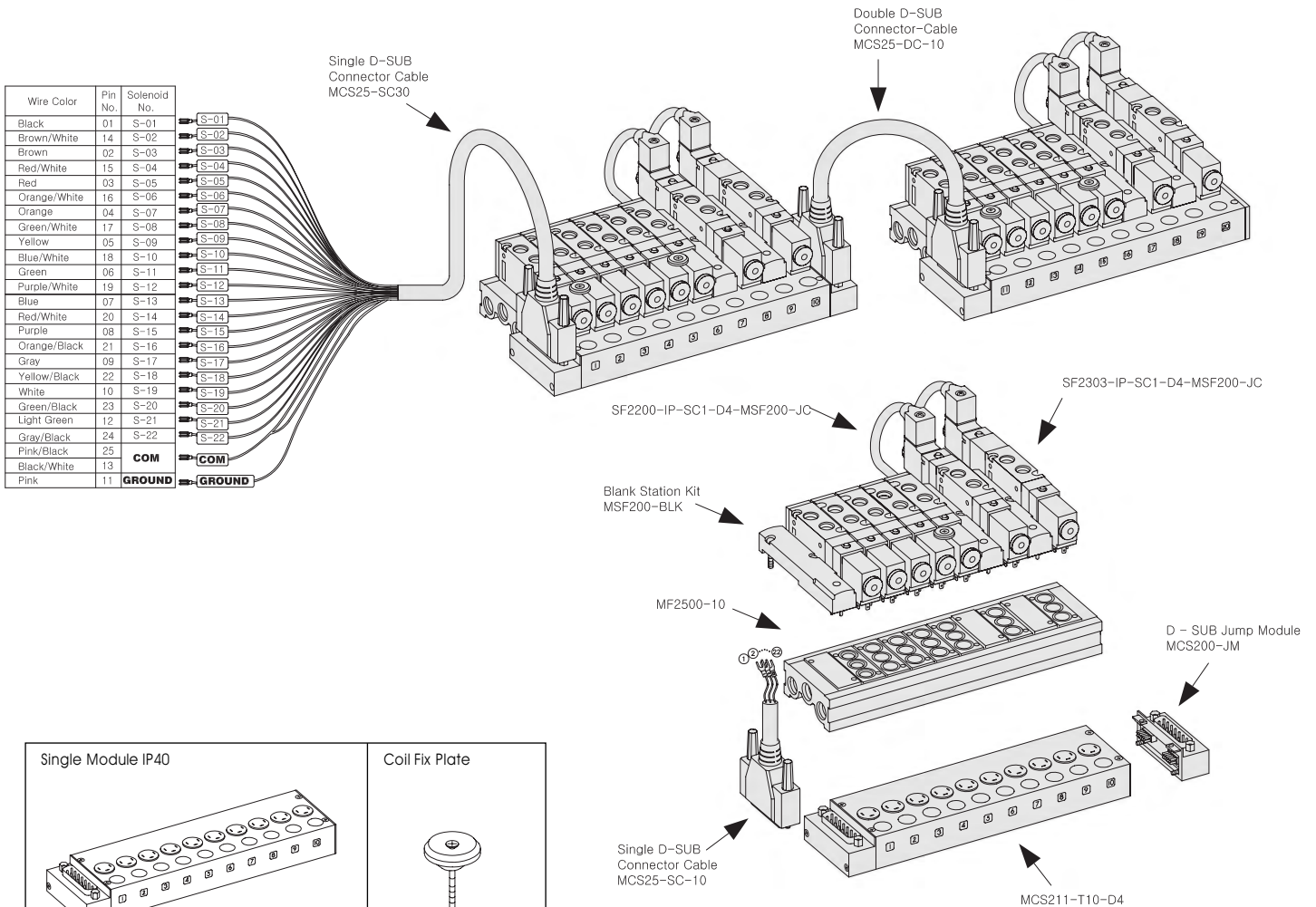

<p>Single Module IP40</p> <p>Ordering Code MCS211-T10-D4</p>	<p>Coil Fix Plate</p> <p>Ordering Code MCS200-CP</p>				
<p>Double Module IP40</p> <p>Ordering Code MCS221-T10-D4</p>	<p>D-Sub Jump Module IP40 (Material : Zinc)</p> <p>Ordering Code MCS200-JM</p>	<p>Single D-Sub Connector Cable IP40</p> <p>Ordering Code MCS25-SC-10 (1m) MCS25-SC-30 (3m) MCS25-SC-50 (5m) MCS25-SC-100 (10m)</p>	<p>Double D-Sub Connector Cable IP40</p> <p>Ordering Code MCS25-DC-05 (0.5m) MCS25-DC-10 (10m)</p>	<p>Blank Station Kit (Material : Zinc)</p> <p>Ordering Code MSF200-BLK</p>	<p>Jump Connector Kit IP40</p> <p>Ordering Code MSF200-JC</p>

## ORDERING NO.

**MCS2 1 1 - T04 - D4**

Series	Function	D-Sub Connector	Multipole Wireway Box	Voltage																														
MCS2 : SF2000-1/8-5Port Solenoid Valve Ass'y	<table border="1"> <tr><td>0</td><td>None</td></tr> <tr><td>1</td><td>Single Module</td></tr> <tr><td>2</td><td>Double Module</td></tr> </table>	0	None	1	Single Module	2	Double Module	<table border="1"> <tr><td>0</td><td>None</td></tr> <tr><td>1</td><td>25 Pin D-Sub Connector</td></tr> </table>	0	None	1	25 Pin D-Sub Connector	<table border="1"> <tr><td>0</td><td>None</td></tr> <tr><td>T04</td><td>4 Station</td></tr> <tr><td>T06</td><td>6 Station</td></tr> <tr><td>T08</td><td>8 Station</td></tr> <tr><td>T10</td><td>10 Station</td></tr> <tr><td>T12</td><td>12 Station</td></tr> <tr><td>T14</td><td>14 Station</td></tr> </table>	0	None	T04	4 Station	T06	6 Station	T08	8 Station	T10	10 Station	T12	12 Station	T14	14 Station	<table border="1"> <tr><td>0</td><td>None</td></tr> <tr><td>D4</td><td>DC 24V</td></tr> <tr><td>D2</td><td>DC 12V</td></tr> </table>	0	None	D4	DC 24V	D2	DC 12V
0	None																																	
1	Single Module																																	
2	Double Module																																	
0	None																																	
1	25 Pin D-Sub Connector																																	
0	None																																	
T04	4 Station																																	
T06	6 Station																																	
T08	8 Station																																	
T10	10 Station																																	
T12	12 Station																																	
T14	14 Station																																	
0	None																																	
D4	DC 24V																																	
D2	DC 12V																																	

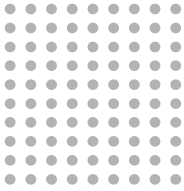

### MCS211-T10-D4

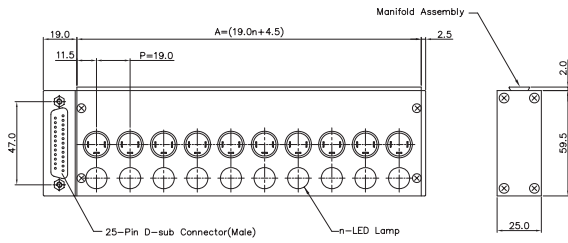

### MCS221-T10-D4

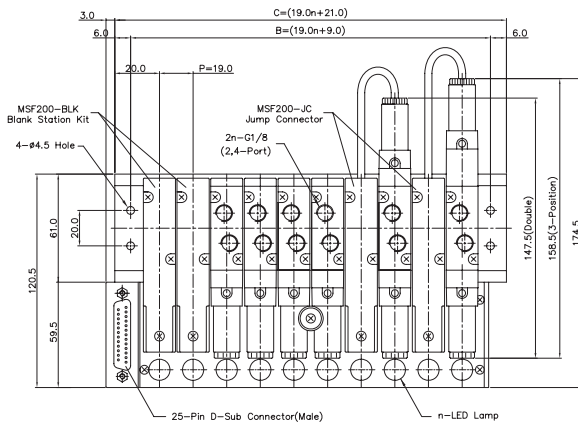
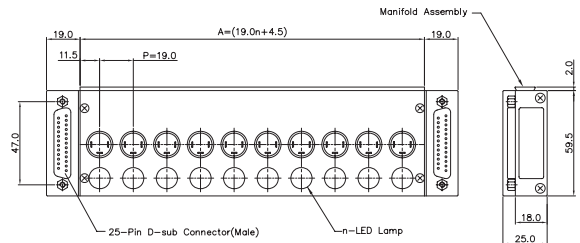

n = STATION

ITEM	n	4	6	8	10	12	14
A		80.5	118.5	156.5	194.5	232.5	270.5
B		85.0	123.0	161.0	199.0	237.0	275.0
C		97.0	135.0	173.0	211.0	249.0	287.0

### D-Sub Connector Pin No.

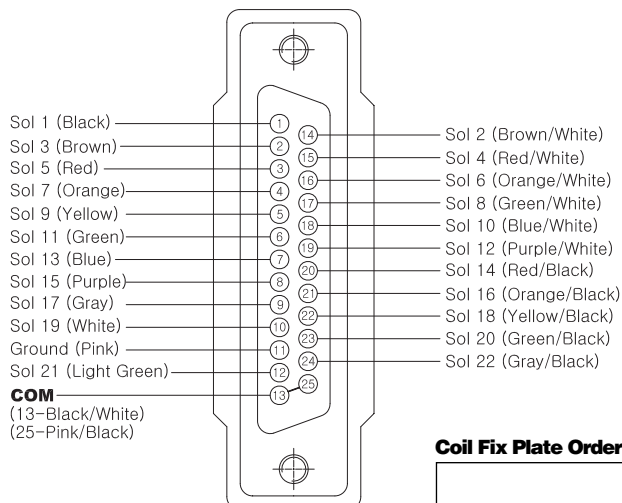

### Coil Fix Plate Ordering Code

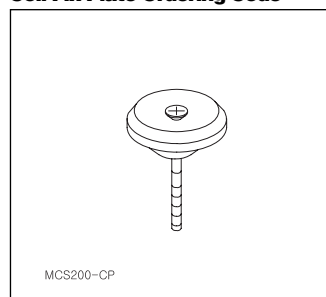

### Blank Station Kit Ordering Code

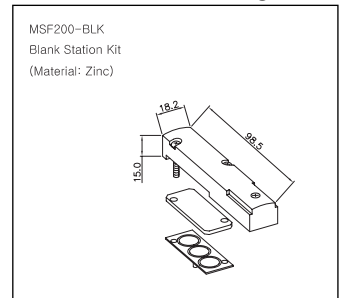

### Jump Connector Cable Ordering Code

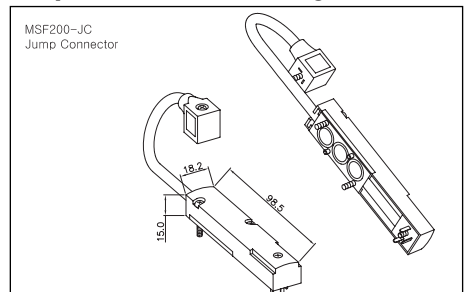

### Single D-Sub Connector Cable Ordering Code

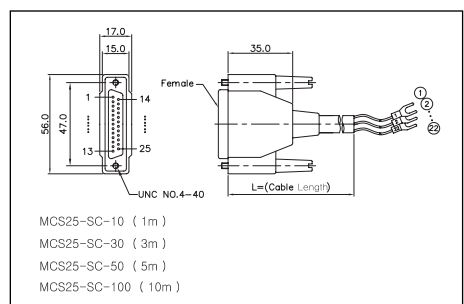

### Double D-Sub Connector Cable Ordering Code

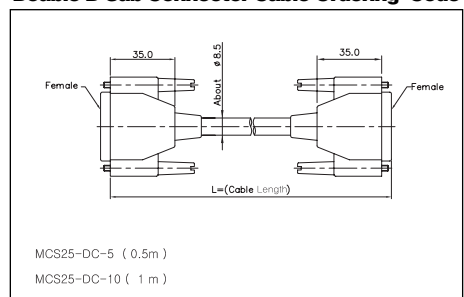



# MCS400

Multi Connector System  
SF4000 Solenoid Valve MOUNTED

- DC 24V / DC 12V
- 25Pin D-Sub Connector
- Simple Electric Wire System

Wire Color	Pin No.	Solenoid No.	
Black	01	S-01	S-01
Brown/White	14	S-02	S-02
Brown	02	S-03	S-03
Red/White	15	S-04	S-04
Red	03	S-05	S-05
Orange/White	16	S-06	S-06
Orange	04	S-07	S-07
Green/White	17	S-08	S-08
Yellow	05	S-09	S-09
Blue/White	18	S-10	S-10
Green	06	S-11	S-11
Purple/White	19	S-12	S-12
Blue	07	S-13	S-13
Red/White	20	S-14	S-14
Purple	08	S-15	S-15
Orange/Black	21	S-16	S-16
Gray	09	S-17	S-17
Yellow/Black	22	S-18	S-18
White	10	S-19	S-19
Green/Black	23	S-20	S-20
Light Green	12	S-21	S-21
Gray/Black	24	S-22	S-22
Pink/Black	25	COM	COM
Black/White	13	COM	COM
Pink	11	GROUND	GROUND

Single D-SUB Connector Cable MCS25-SC-30

Double D-SUB Connector Cable MCS25-DC-10

SF4200-IP-SC2-D4-MSF400-JC

SF4303-IP-SC2-D4-MSF400-JC

Blank Station Kit MSF400-BLK

MF4500-10

D - SUB Jump Module MCS400-JM

MCS411-T10-D4

Single D-SUB Connector Cable MCS25-SC-10

Single Module IP40

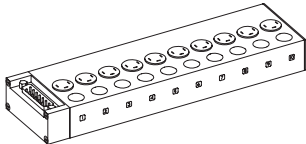

Ordering Code  
MCS411-T10-D4

Coil Fix Plate



Ordering Code  
MCS200-CP

Double Module IP40

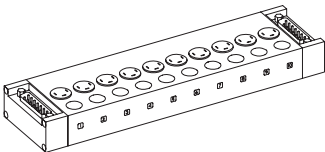

Ordering Code  
MCS421-T10-D4

D-Sub Jump Module IP40 (Material : Zinc)



Ordering Code  
MCS400-JM

Single D-Sub Connector Cable IP40

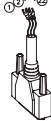

Ordering Code  
MCS25-SC-10 (1m)  
MCS25-SC-30 (3m)  
MCS25-SC-50 (5m)  
MCS25-SC-100 (10m)

Double D-Sub Connector Cable IP40

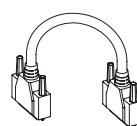

Ordering Code  
MCS25-DC-05 (0.5m)  
MCS25-DC-10 (1m)

Blank Station Kit (Material : Zinc)

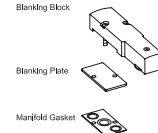

Ordering Code  
MSF400-BLK

Jump Connector Kit IP40

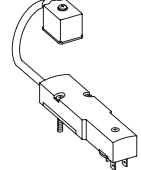

Ordering Code  
MSF400-JC

## ORDERING NO.

**MCS4 1 1 - T04 - D4**

Series

MCS4 :  
SF4000-1/4-5Port  
Solenoid Valve Ass'y

Function

0	None
1	Single Module
2	Double Module

D-Sub Connector

0	None
1	25 Pin D-Sub Connector

Multipole Wireway Box

0	None
T04	4 Station
T06	6 Station
T08	8 Station
T10	10 Station
T12	12 Station
T14	14 Station

Voltage

0	None
D4	DC 24V
D2	DC 12V

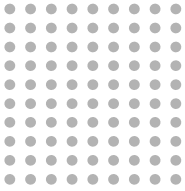

### MCS411-T10-D4

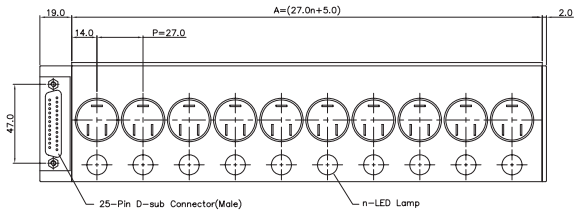

### MCS421-T10-D4

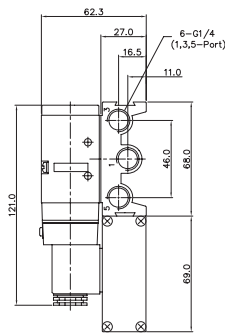
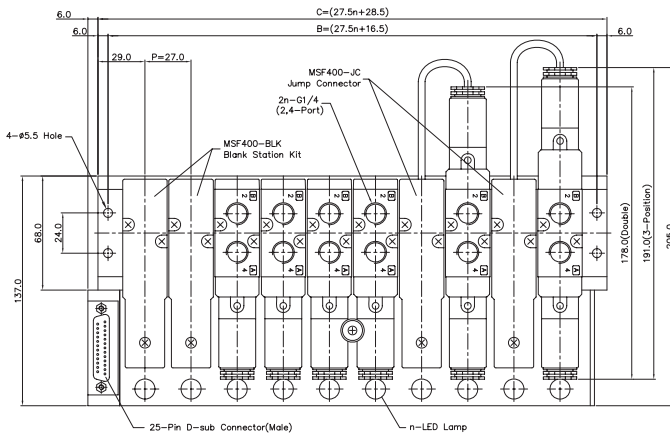
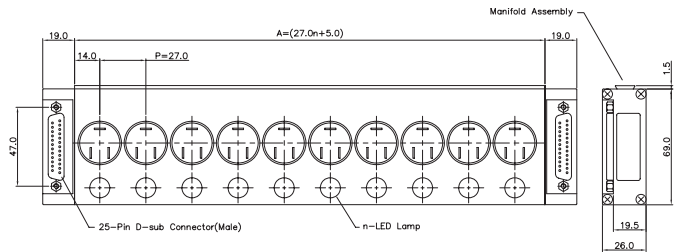

### Blank Station Kit Ordering Code

MSF400-BLK  
Blank Station Kit  
(Material: Zinc)

		n = STATION					
ITEM	n	4	6	8	10	12	14
A		113.0	167.0	221.0	275.0	329.0	383.0
B		126.5	181.5	236.5	291.5	346.5	401.5
C		138.5	193.5	248.5	303.5	358.5	413.5

### D-Sub Connector Pin No.

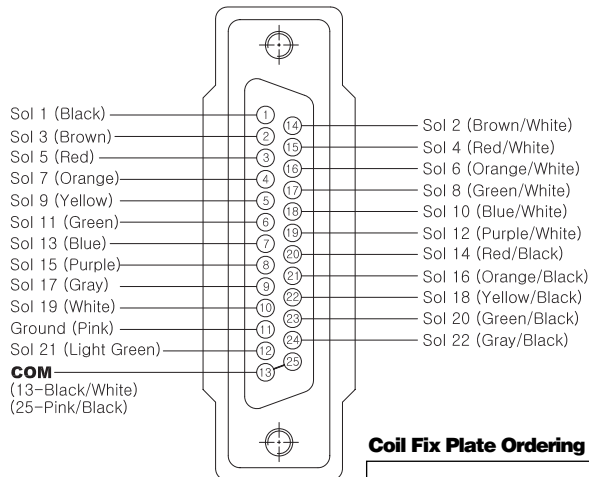

### Coil Fix Plate Ordering Code

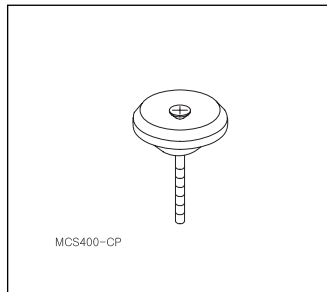

### Jump Connector Cable Ordering Code

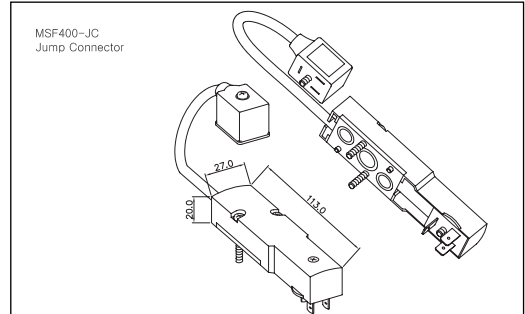

### Single D-Sub Connector Cable Ordering Code

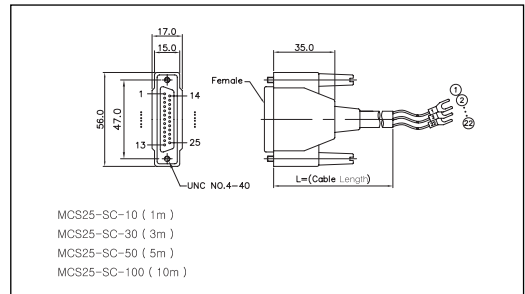

### Double D-Sub Connector Cable Ordering Code

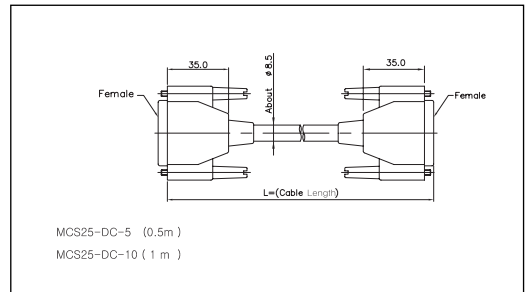





# SF (FLEXIBLE) Series

## 5/2, 5/3, 3/2 Solenoid, Pneumatic Valve

### CHAPTER 03



SF1000  
Body Width-15mm  
Thread-M5



SF2000  
Body Width-18mm  
Thread-1/8



SF3000  
Body Width-23mm  
Thread-1/8



SF4000  
Body Width-26mm  
Thread-1/4



SF5000  
Body Width-32mm  
Thread-3/8



SF6000  
Body Width-36mm  
Thread-1/2

- SF1000
- SF2000
- SF3000
- SF4000
- SF5000
- SF6000

# SF1000. M5

"F" FLEXIBLE Series  
Solenoid / Pneumatic Valves

- 5/2, 5/3, 3/2 - M5
- 15mm Body Width
- Transition Flow 200ℓ/min (5bar)

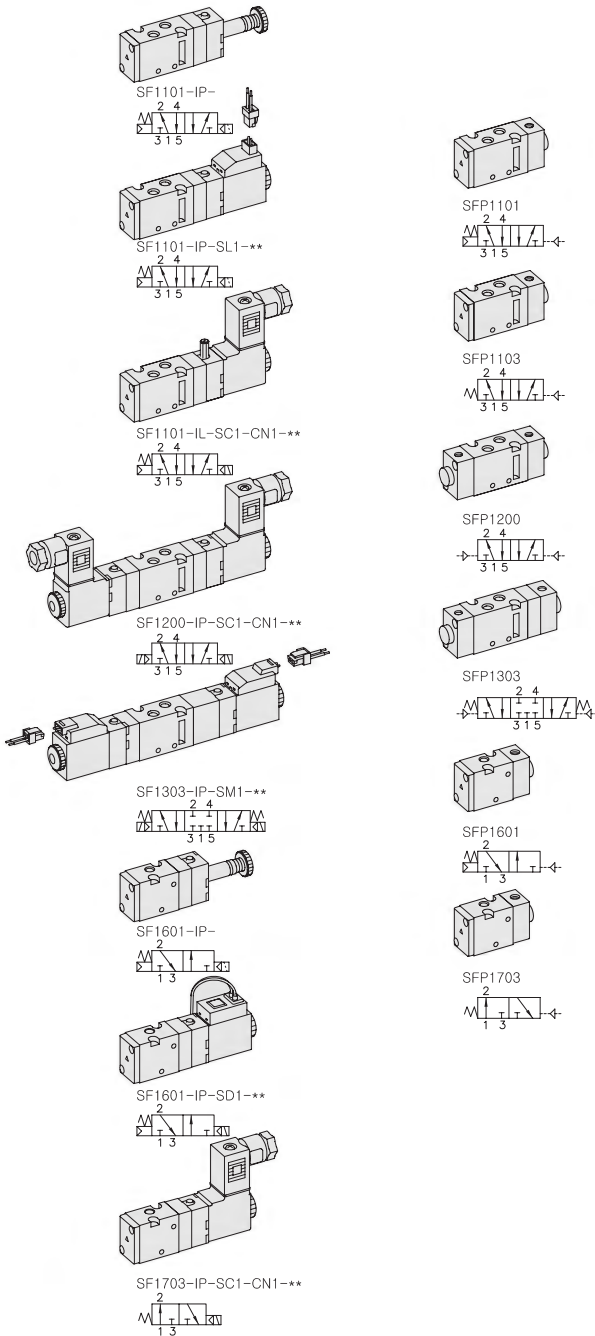

\*\* : Voltage Selection (see page 80)

## SPECIFICATION

ITEM	SERIES	SOLENOID, PNEUMATIC	
		FUNCTION	
		5, 3 Port 2 Position	5 Port 3 Position
Fluids		Compressed Air & Inert Gases	
Pressure(bar)		1.5~10.0	2.0~10.0
Eff. Section Area(mm <sup>2</sup> )-5bar		3.6	3.0
Ambient & Fluid Temp.		5~60°C (41~140°F)	
Response Time(5bar)		25ms or Less	35ms or Less
Max. Working Frequency		5c/sec	3c/sec
Lubrication		Not Required(Use ISO VG32 #)	
Manual Override		Push Button(Standard), Lever Lock(Option)	
Coil Insulation Class		F-Class or Equivalent	
Permissible Voltage Variation		±10% of Rated Voltage	
Off Min. Residual Voltage		AC:20% or Less / DC:10% or Less	
Power Consumption		Holding-AC:3.5VA(60Hz) / DC:2.5W	

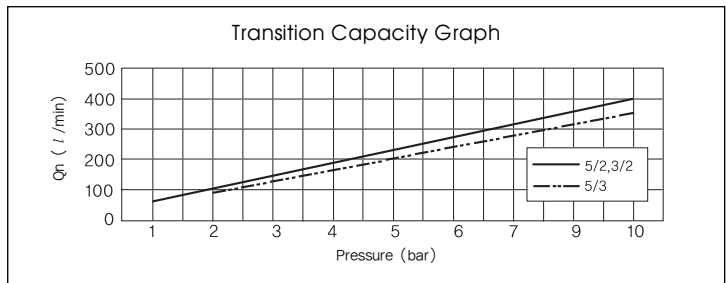

- ### The Material of Parts
- Valve Body : Die-Cast Aluminium
  - Spool : Aluminium
  - Seals : NBR
  - Spring : Stainless
  - Cap : Zinc Pressure Die-Cast
  - Pilot Parts : Glass Filled Nylon
  - Armature : Stainless Steel
  - Armature Seals : Viton

### Plug Connector With Clip

**Ordering Code**  
PG2-06 ( L : 600mm)  
PG2-10 ( L : 1,000mm)

\* The specification on each item can be amended without any prenotice to improve a performance.  
\* The specification on each item can be different from actual specification.

## ORDERING NO.

**SF1 1 0 1 - I P - SC1 - CN1 - A2**

Valve Series	Function	Port Size & Thread	Return Method	Int/Ext. Pilot	Manual Operator	Solenoid Coil Type	Connector Type	Voltage
SF1 : Solenoid Valve	1 5/2 Single	0 M5×0.8	0 None	I Internal Pilot	0 None	0 None	0 None	0 None
	2 5/2 Double	1 10-32 UNF	1 Air + Spring		P Push Non-Locking	SC1 3 Pin Connector Coil	CN1 Normal Connector	A2 AC 220V
	3 5/3 Closed Center		2 Air		L Lever Locking	SG1 Grommet/Flying Leads	CD1 Connector With LED	A1 AC 110V
SFP1 : Pneumatic Valve	4 5/3 Open Center		3 Spring			SD1 Grommet/Flying Leads With LED	CZ1 Connector With LED & Surge Suppressor	A4 AC 24V
	5 5/3 Pressure Center					SL1 90 Degree Plug-in Wire Assembly With LED		D4 DC 24V
	6 3/2 Normally Closed					SM1 180 Degree Plug-in Wire Assembly With LED		D2 DC 12V
	7 3/2 Normally Open							

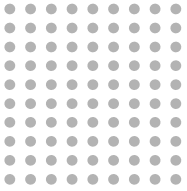

# Solenoid & Pilot Actuated Spool Valves

Port Thread **M5 × 0.8**

## 5Port 2Position Solenoid Valve

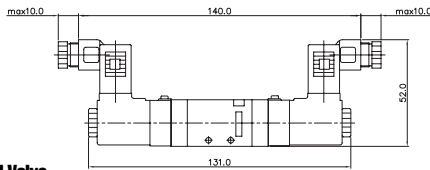
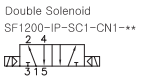
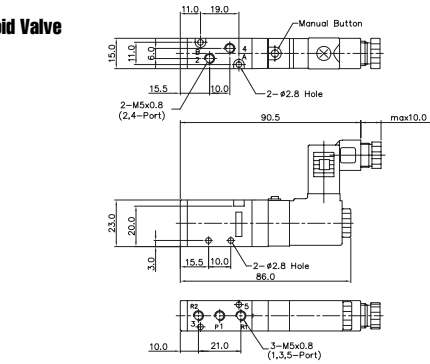
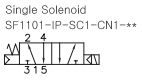

## 5Port 3Position Solenoid Valve

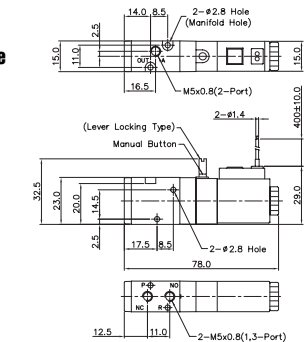
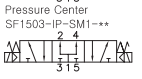
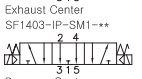
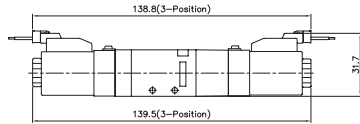
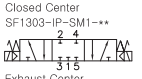

## 3Port 2Position Solenoid Valve

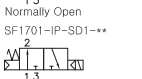
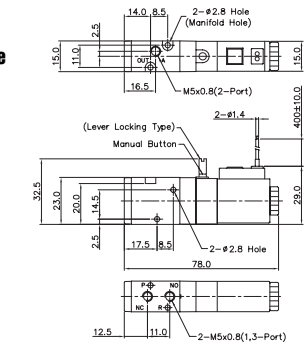
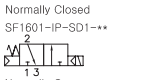

## 5Port 2Position Pneumatic Valve

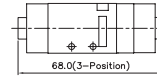
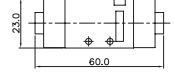
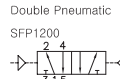
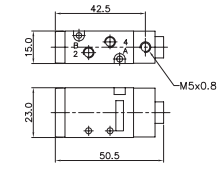
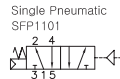

## 5Port 3Position Pneumatic Valve

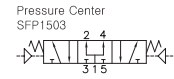
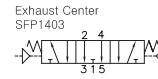
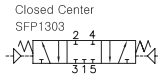

## 3Port 2Position Pneumatic Valve

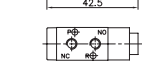
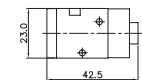
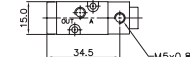
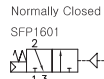

# MF1000 MANIFOLD BLOCK

(SF1000 Solenoid & Pneumatic Valve Use)

## 5-Port Manifold Block

MF1500-4

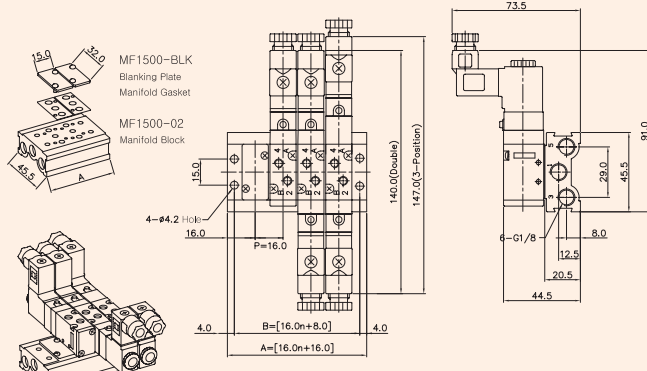

SPORT MANIFOLD BLOCK DIMENSION		n-STATION				
ITEM	n	2	4	6	8	10
B		40.0	72.0	104.0	136.0	168.0
A		48.0	80.0	112.0	144.0	176.0

## Manifold Block Ordering Code

MF 1500 - 2		
Series	Manifold Station	
MF1500	5 Way	
MF1300	3 Way	
	02	2-Station
	04	4-Station
	06	6-Station
	08	8-Station
	10	10-Station

## Blanking Plate Ordering Code

MF1500-BLK	
Blanking Plate. (Material : SCP1)	
Manifold Gasket. (Material : NBR)	
MF1300-BLK	
Blanking Plate. (Material : SCP1)	
Manifold Gasket. (Material : NBR)	

## 3-Port Manifold Block

MF1300-4

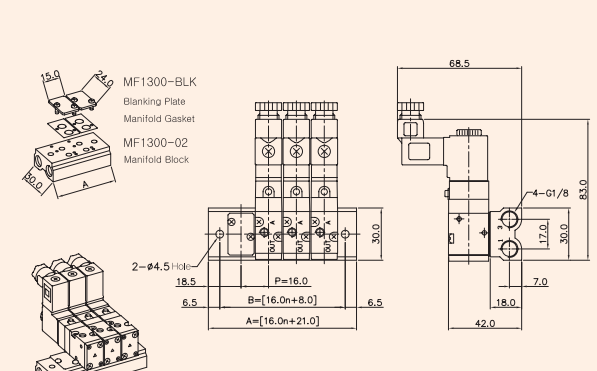

3PORT MANIFOLD BLOCK DIMENSION		n-STATION				
ITEM	n	2	4	6	8	10
B		40.0	72.0	104.0	136.0	168.0
A		53.0	85.0	117.0	149.0	181.0

# SF2000. 1/8

"F" FLEXIBLE Series  
Solenoid / Pneumatic Valves

- 5/2, 5/3, 3/2 - 1/8
- 18mm Body Width
- Transition Flow 700ℓ/min (5bar)

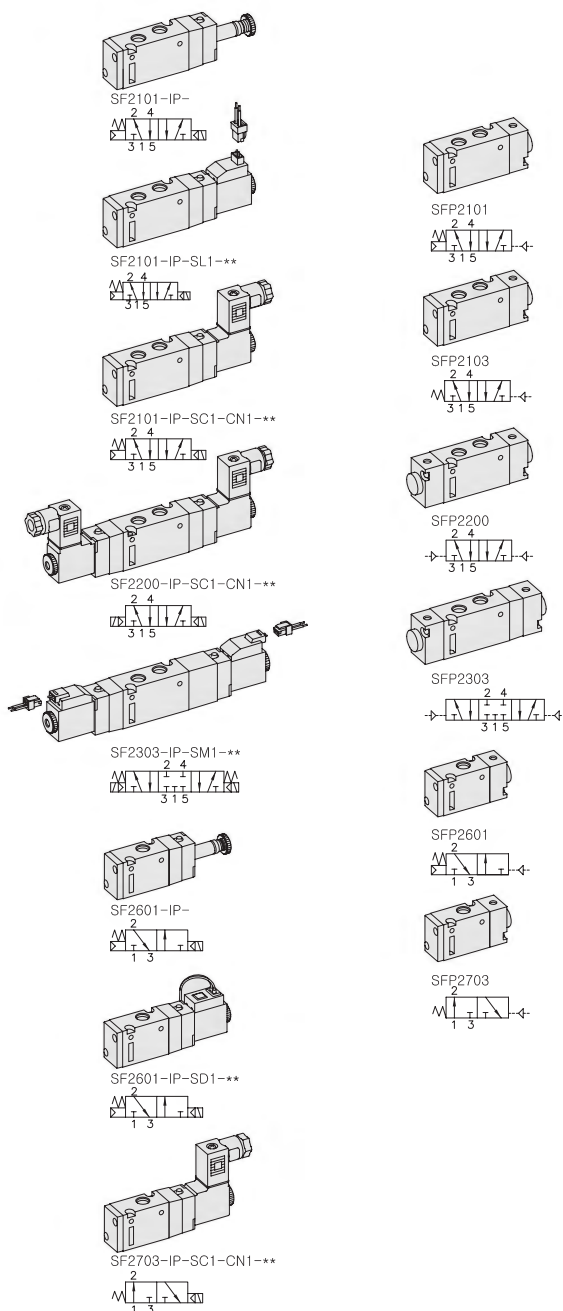

\*\* : Voltage Selection (see page 80)

## SPECIFICATION

ITEM	SERIES	SOLENOID, PNEUMATIC	
		FUNCTION	
		5, 3 Port 2 Position	5 Port 3 Position
Fluids		Compressed Air & Inert Gases	
Pressure(bar)		1.5~10.0	2.0~10.0
Eff. Section Area(mm <sup>2</sup> )-5bar		12.6	9.0
Ambient & Fluid Temp.		5~60°C (41~140°F)	
Response Time(5bar)		25ms or Less	35ms or Less
Max. Working Frequency		5c/sec	3c/sec
Lubrication		Not Required(Use ISO VG32 #)	
Manual Override		Push Button(Standard), Lever Lock(Optional)	
Coil Insulation Class		F-Class or Equivalent	
Permissible Voltage Variation		±10% of Rated Voltage	
Off Min. Residual Voltage		AC:20% or Less / DC:10% or Less	
Power Consumption		Holding-AC:3.5VA(60Hz) / DC:2.5W	

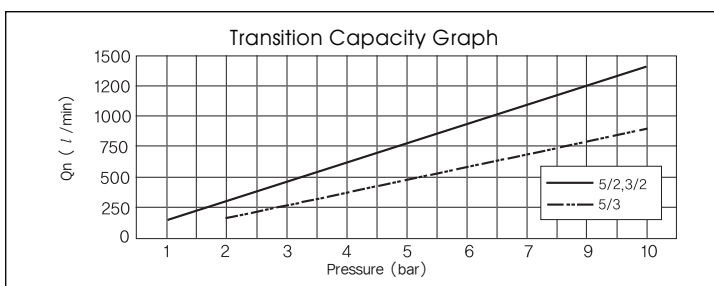

- ### The Material of Parts
- Valve Body : Die-Cast Aluminium
  - Spool : Aluminium
  - Seals : NBR
  - Spring : Stainless
  - Cap : Zinc Pressure Die-Cast
  - Pilot Parts : Glass Filled Nylon
  - Armature : Stainless Steel
  - Armature Seals : Viton

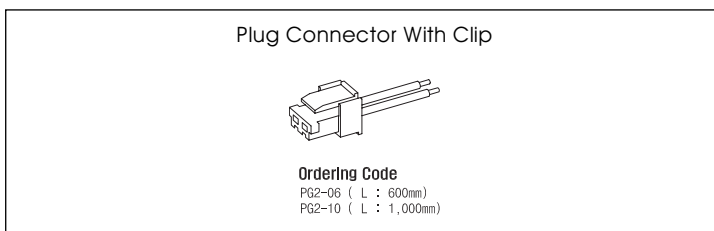

\* The specification on each item can be amended without any prenotice to improve a performance.  
\* The specification on each item can be different from actual specification.

## ORDERING NO.

**SF2 1 0 1 - I P - SC1 - CN1 - A2**

Valve Series	Function	Port Size & Thread	Return Method	Int/Ext. Pilot	Manual Operator	Solenoid Coil Type	Connector Type	Voltage
SF2 : Solenoid Valve	1 5/2 Single	0 G 1/8	0 None	I Internal Pilot	0 None	0 None	0 None	0 None
	2 5/2 Double	1 NPT 1/8	1 Air + Spring		P Push Non-Locking	SC1 3 Pin Connector Coil	CN1 Normal Connector	A2 AC 220V
	3 5/3 Closed Center		2 Air		L Lever Locking	SG1 Grommet/Flying Leads	CD1 Connector With LED	A1 AC 110V
SFP2 : Pneumatic Valve	4 5/3 Open Center		3 Spring			SD1 Grommet/Flying Leads With LED	CZ1 Connector With LED & Surge Suppressor	A4 AC 24V
	5 5/3 Pressure Center					SL1 90 Degree Plug-in Wire Assembly With LED		D4 DC 24V
	6 3/2 Normally Closed					SM1 180 Degree Plug-in Wire Assembly With LED		D2 DC 12V
	7 3/2 Normally Open							



# SF3000. 1/8

"F" FLEXIBLE Series  
Solenoid / Pneumatic Valves

- 5/2, 5/3 - 1/8
- 23mm Body Width
- Transition Flow 760ℓ/min (5bar)

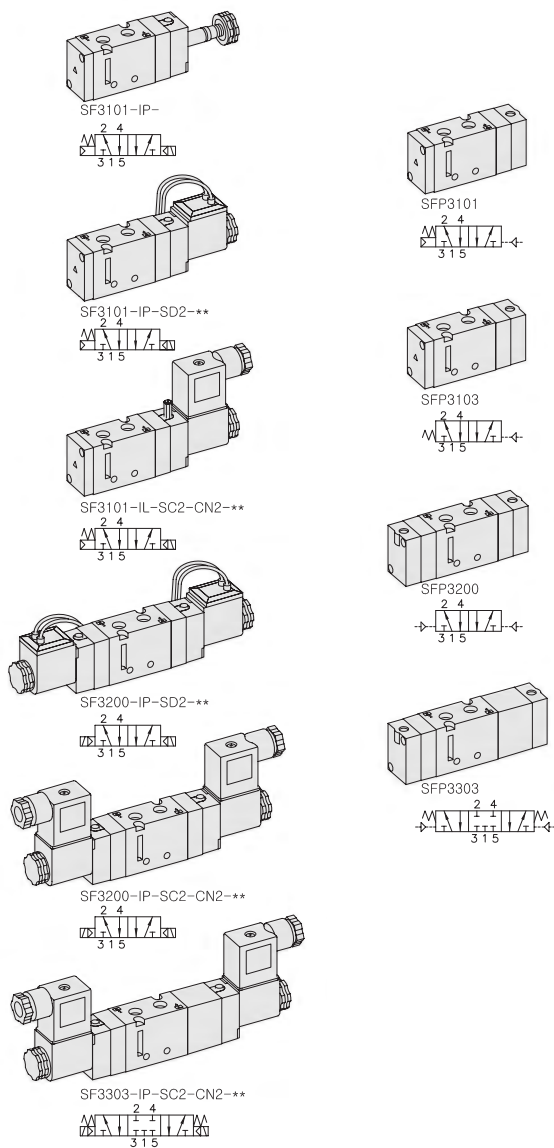

\*\* : Voltage Selection (see page 80)

## SPECIFICATION

ITEM	SERIES	SOLENOID, PNEUMATIC	
		5 Port 2 Position	5 Port 3 Position
Fluids		Compressed Air & Inert Gases	
Pressure(bar)		1.5~10.0	2.0~10.0
Eff. Section Area(mm <sup>2</sup> )-5bar		13.5	11.0
Ambient & Fluid Temp.		5~60°C (41~140°F)	
Response Time(5bar)		25ms or Less	35ms or Less
Max. Working Frequency		5c/sec	3c/sec
Lubrication		Not Required(Use ISO VG32 #)	
Manual Override		Push Button(Standard), Lever Lock(Option)	
Coil Insulation Class		F-Class or Equivalent	
Permissible Voltage Variation		±10% of Rated Voltage	
Off Min. Residual Voltage		AC:20% or Less / DC:10% or Less	
Power Consumption		Holding-AC:5.5VA(60Hz) / DC:2.5W	

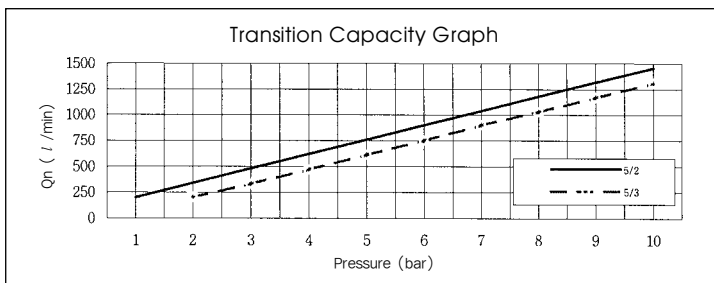

### The Material of Parts

- Valve Body : Die-Cast Aluminium
- Spool : Aluminium
- Seals : NBR
- Spring : Stainless
- Cap : Zinc Pressure Die-Cast
- Pilot Parts : Glass Filled Nylon
- Armature : Stainless Steel
- Armature Seals : Viton

\* The specification on each item can be amended without any prenotice to improve a performance.  
\* The specification on each item can be different from actual specification.

## ORDERING NO.

**SF3 1 0 1 - I P - SC2 - CN2 - A2**

Valve Series	Function	Port Size & Thread	Return Method	Int/Ext. Pilot	Manual Operator	Solenoid Coil Type	Connector Type	Voltage
SF3 : Solenoid Valve	1 5/2 Single	0 G 1/8	0 None	I Internal Pilot	O None	O None	O None	O None
	2 5/2 Double	1 NPT 1/8	1 Air + Spring		P Push	SC2 3 Pin Connector Coil	CN2 Normal Connector	A2 AC 220V
	3 5/3 Closed Center		2 Air			SG2 Grommet/Flying Leads	CD2 Connector With LED	A1 AC 110V
	4 5/3 Open Center		3 Spring		L Lever Locking	SD2 Grommet/Flying Leads With LED	C22 Connector With LED & Surge Suppressor	A4 AC 24V D4 DC 24V D2 DC 12V
SFP3 : Pneumatic Valve	5 5/3 Pressure Center							



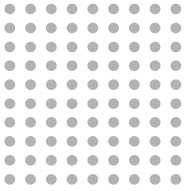

# Solenoid & Pilot Actuated Spool Valves

Port Thread 1/8

## 5Port 2Position Solenoid Valve

Single Solenoid  
SF3101-IP-SD2-\*\*\*

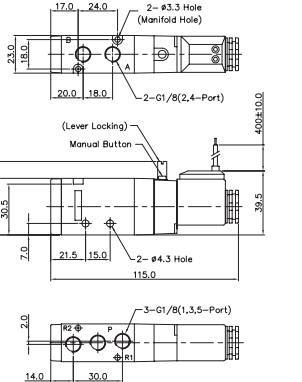

SF3101-IP-SC2-CN2-\*\*\*

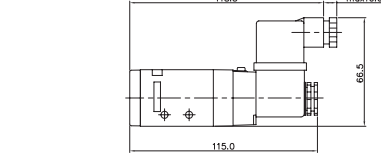

Double Solenoid  
SF3200-IP-SC2-CN2-\*\*\*

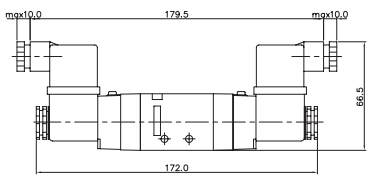

## 5Port 3Position Solenoid Valve

Closed Center  
SF3303-IP-SC2-CN2-\*\*\*

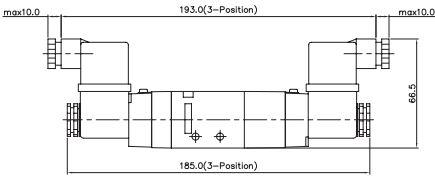
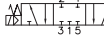

Exhaust Center  
SF3403-IP-SC2-CN2-\*\*\*

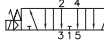

Pressure Center  
SF3503-IP-SC2-CN2-\*\*\*

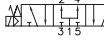

## 5Port 2Position Pneumatic Valve

Single Pneumatic  
SFP3101

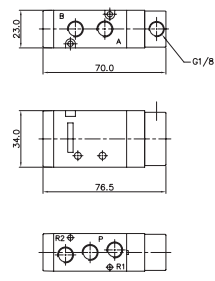
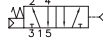

Double Pneumatic  
SFP3200

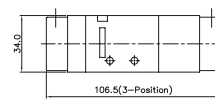
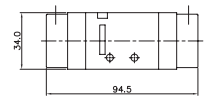
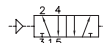

## 5Port 3Position Pneumatic Valve

Closed Center  
SFP3303



Exhaust Center  
SFP3403



Pressure Center  
SFP3503



# MF3000 MANIFOLD BLOCK

(SF3000 Solenoid & Pneumatic Valve Use)

### Manifold Block Ordering Code

**MF 3500 - 2**

Series	Manifold Station
MF3500 5 Way	02 2-Station
	04 4-Station
	06 6-Station
	08 8-Station
	10 10-Station

### Blanking Plate Ordering Code

MF3500-BLK

Blanking Plate.  
(Material: SCP1)

Manifold Gasket.  
(Material: NBR)

## 5-Port Manifold Block

MF3500-4

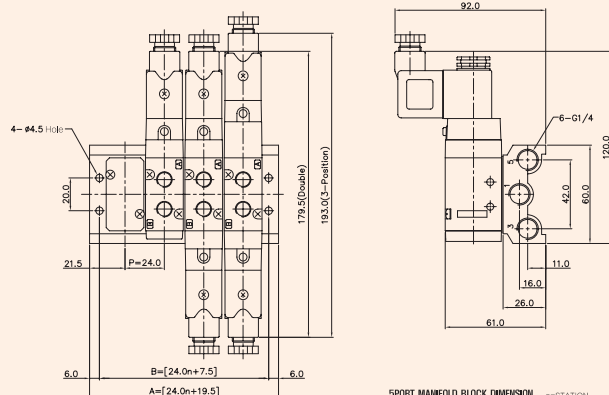
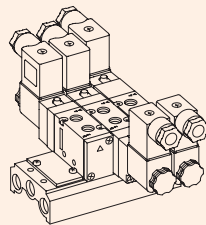
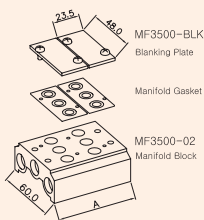

SPORT MANIFOLD BLOCK DIMENSION						n=STATION
ITEM	2	4	6	8	10	
B	55.5	103.5	151.5	199.5	247.5	
A	67.5	115.5	163.5	211.5	259.5	

# SF4000. 1/4

"F" FLEXIBLE Series  
Solenoid / Pneumatic Valves

- 5/2, 5/3, 3/2 - 1/4
- 26mm Body Width
- Transition Flow 1000ℓ/min (5bar)

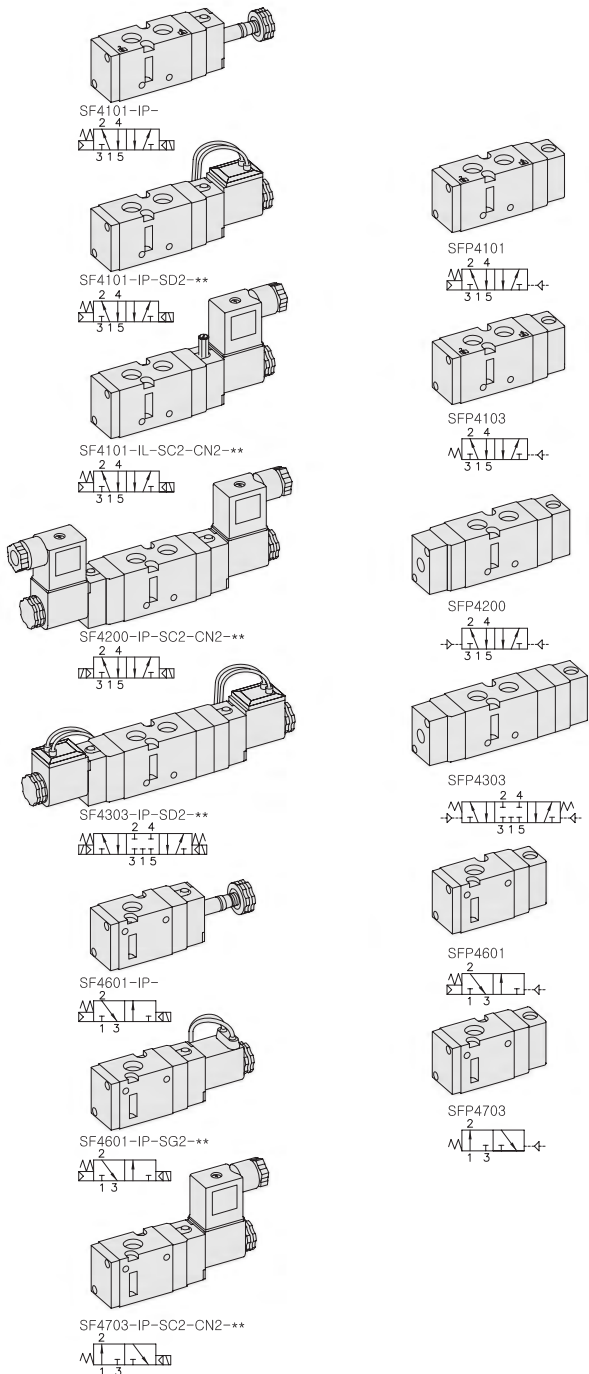

\*\* : Voltage Selection (see page 80)

## SPECIFICATION

ITEM	SERIES	SOLENOID, PNEUMATIC	
		FUNCTION	
		5, 3 Port 2 Position	5 Port 3 Position
Fluids		Compressed Air & Inert Gases	
Pressure(bar)		1.5~10.0	2.0~10.0
Eff. Section Area(mm <sup>2</sup> )-5bar		19.0	11.5
Ambient & Fluid Temp.		5~60°C (41~140°F)	
Response Time(5bar)		25ms or Less	35ms or Less
Max. Working Frequency		5c/sec	3c/sec
Lubrication		Not Required(Use ISO VG32 #)	
Manual Override		Push Button(Standard), Lever Lock(Option)	
Coil Insulation Class		F-Class or Equivalent	
Permissible Voltage Variation		±10% of Rated Voltage	
Off Min. Residual Voltage		AC:20% or Less / DC:10% or Less	
Power Consumption		Holding-AC:5.5VA(60Hz) / DC:2.5W	

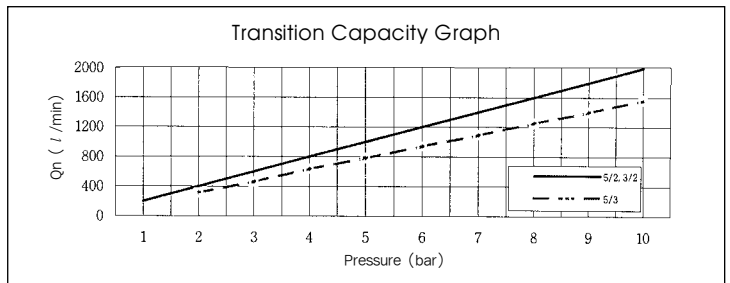

### The Material of Parts

■ Valve Body : Die-Cast Aluminium	■ Pilot Parts : Glass Filled Nylon
■ Spool : Aluminium	■ Armature : Stainless Steel
■ Seals : NBR	■ Armature Seals : Viton
■ Spring : Stainless	
■ Cap : Zinc Pressure Die-Cast	

\* The specification on each item can be amended without any prenotice to improve a performance.  
\* The specification on each item can be different from actual specification.

## ORDERING NO.

**SF4 1 0 1 - I P - SC2 - CN2 - A2**

Valve Series	Function	Port Size & Thread	Return Method	Int/Ext. Pilot	Manual Operator	Solenoid Coil Type	Connector Type	Voltage
SF4 : Solenoid Valve	1 5/2 Single	0 G 1/4	0 None	I Internal Pilot	0 None	0 None	0 None	0 None
	2 5/2 Double	1 NPT 1/4	1 Air + Spring		P Push Non-Locking	SC2 3 Pin Connector Coil	CN2 Normal Connector	A2 AC 220V
	3 5/3 Closed Center		2 Air		L Lever Locking	SG2 Grommet/Flying Leads	CD2 Connector With LED	A1 AC 110V
	4 5/3 Open Center		3 Spring			SD2 Grommet/Flying Leads With LED	CZ2 Connector With LED & Surge Suppressor	A4 AC 24V
SFP4 : Pneumatic Valve	5 5/3 Pressure Center							A4 AC 24V
	6 3/2 Normally Closed							D4 DC 24V
	7 3/2 Normally Open							D2 DC 12V

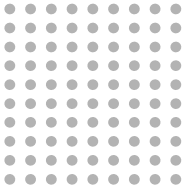

# Solenoid & Pilot Actuated Spool Valves

Port Thread 1/4

## 5Port 2Position Solenoid Valve

Single Solenoid  
SF4101-IP-SC2-CN2-\*

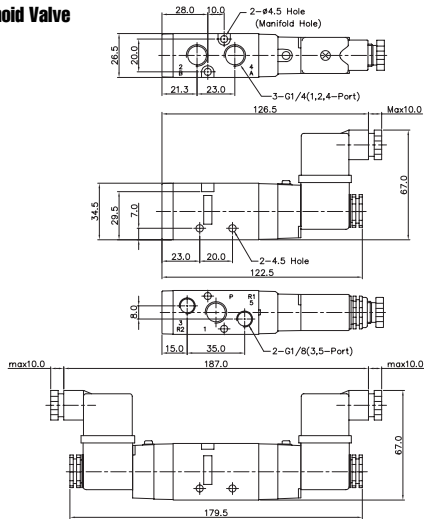
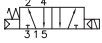

Double Solenoid  
SF4200-IP-SD2-\*

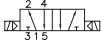

## 5Port 3Position Solenoid Valve

Closed Center  
SF4303-IP-SC2-CN2-\*

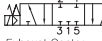

Exhaust Center  
SF4403-IP-SC2-CN2-\*

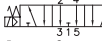

Pressure Center  
SF4503-IP-SC2-CN2-\*

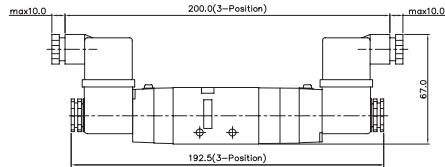
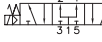

## 3Port 2Position Solenoid Valve

Normally Closed  
SF4601-IP-SD2-\*

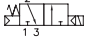

Normally Open  
SF4701-IP-SD2-\*

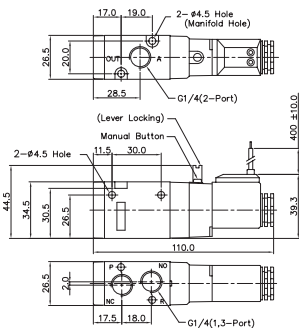
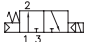

## 5Port 2Position Pneumatic Valve

Single Pneumatic  
SFP4101



Double Pneumatic  
SFP4200

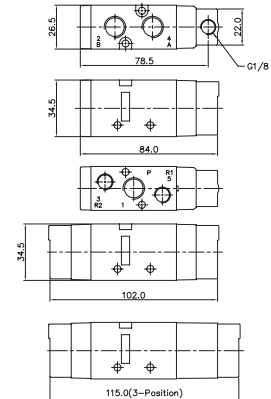
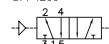

## 5Port 3Position Pneumatic Valve

Closed Center  
SFP4303



Exhaust Center  
SFP4403



Pressure Center  
SFP4503



## 3Port 2Position Pneumatic Valve

Normally Closed  
SFP4601



Normally Open  
SFP4701

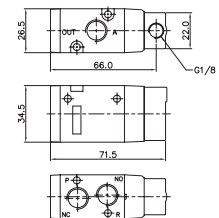

# MF4000 MANIFOLD BLOCK

(SF4000 Solenoid & Pneumatic Valve Use)

## Manifold Block Ordering Code

MF 4500		-		2	
Series	Manifold Station				
MF4500	5 Way	02	2-Station		
MF4300	3 Way	04	4-Station		
		06	6-Station		
		08	8-Station		
		10	10-Station		

## Blanking Plate Ordering Code

MF4500-BLK	Blanking Plate. (Material: SCP1)
MF4300-BLK	Blanking Plate. (Material: SCP1)
	Manifold Gasket. (Material: NBR)
	Manifold Gasket. (Material: NBR)

## 5-Port Manifold Block

MF4500-4

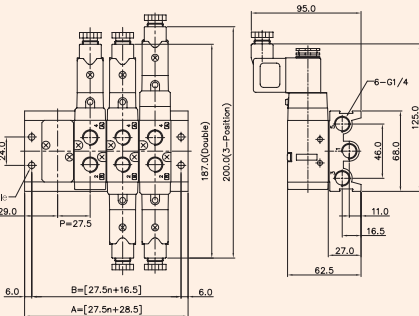
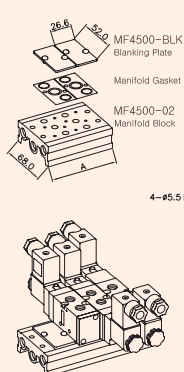

5PORT MANIFOLD BLOCK DIMENSION		n=STATION			
n	2	4	6	8	10
B	71.5	126.5	181.5	236.5	291.5
A	83.5	138.5	193.5	248.5	303.5

## 3-Port Manifold Block

MF4300-4

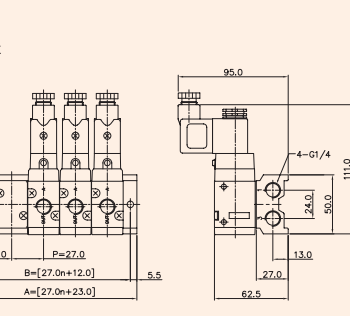
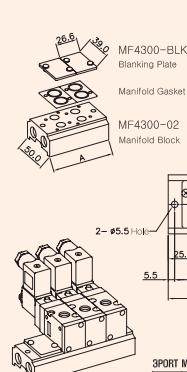

3PORT MANIFOLD BLOCK DIMENSION		n=STATION			
n	2	4	6	8	10
B	66.0	120.0	174.0	228.0	282.0
A	77.0	131.0	185.0	239.0	293.0

# SF5000. 3/8

"F" FLEXIBLE Series  
Solenoid / Pneumatic Valves

- 5/2, 5/3, 3/2 - 3/8
- 32mm Body Width
- Transition Flow 2000ℓ/min (5bar)

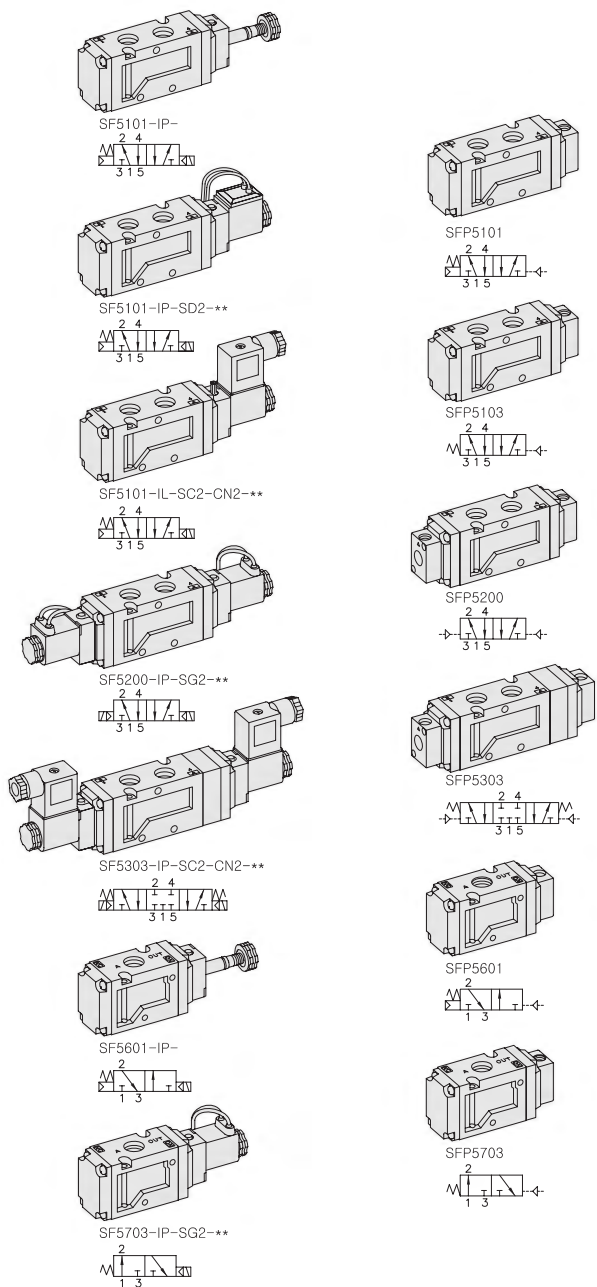

\*\*\*: Voltage Selection (see page 80)

## SPECIFICATION

ITEM	SERIES	SOLENOID, PNEUMATIC	
		FUNCTION	
		5, 3 Port 2 Position	5 Port 3 Position
Fluids		Compressed Air & Inert Gases	
Pressure(bar)		1.5~10.0	2.0~10.0
Eff. Section Area(mm <sup>2</sup> )-5bar		36.0	30.0
Ambient & Fluid Temp.		5~60°C (41~140°F)	
Response Time(5bar)		30ms or Less	40ms or Less
Max. Working Frequency		5c/sec	3c/sec
Lubrication		Not Required(Use ISO VG32 #)	
Manual Override		Push Button(Standard), Lever Lock(Option)	
Coil Insulation Class		F-Class or Equivalent	
Permissible Voltage Variation		±10% of Rated Voltage	
Off Min. Residual Voltage		AC:20% or Less / DC:10% or Less	
Power Consumption		Holding-AC:5.5VA(60Hz) / DC:2.5W	

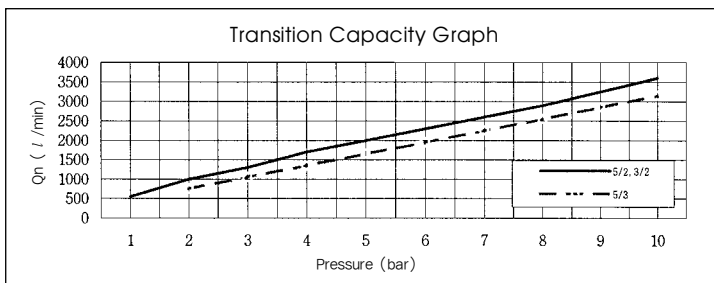

## The Material of Parts

- Valve Body : Die-Cast Aluminium
- Spool : Aluminium
- Seals : NBR
- Spring : Stainless
- Cap : Zinc Pressure Die-Cast
- Pilot Parts : Glass Filled Nylon
- Armature : Stainless Steel
- Armature Seals : Viton

\* The specification on each item can be amended without any prenotice to improve a performance.  
\* The specification on each item can be different from actual specification.

## ORDERING NO.

**SF5 1 0 1 - I P - SC2 - CN2 - A2**

Valve Series	Function	Port Size & Thread	Return Method	Int/Ext. Pilot	Manual Operator	Solenoid Coil Type	Connector Type	Voltage
SF5 : Solenoid Valve	1 5/2 Single	0 G 3/8	0 None	1 Internal Pilot	0 None	0 None	0 None	0 None
	2 5/2 Double	1 NPT 3/8	1 Air + Spring		P Push Non-Locking	SC2 3 Pin Connector Coil	CN2 Normal Connector	A2 AC 220V
	3 5/3 Closed Center		2 Air		L Lever Locking	SG2 Grommet/Flying Leads	CD2 Connector With LED	A1 AC 110V
	4 5/3 Open Center		3 Spring			SD2 Grommet/Flying Leads With LED	CZ2 Connector With LED & Surge Suppressor	A4 AC 24V D4 DC 24V D2 DC 12V
SFP5 : Pneumatic Valve	5 5/3 Pressure Center							
	6 3/2 Normally Closed							
	7 3/2 Normally Open							

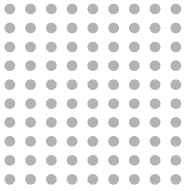

# Solenoid & Pilot Actuated Spool Valves

Port Thread 3/8

## 5Port 2Position Solenoid Valve

Single Solenoid  
SF5300-IP-SC2-CN2-\*\*\*  
22 44  
33 55

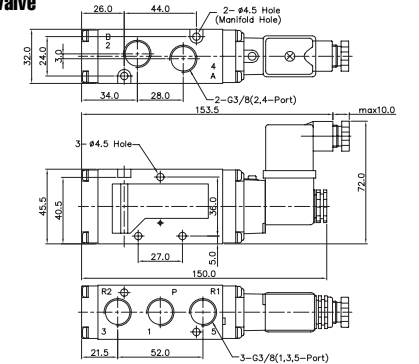

Double Solenoid  
SF5200-IP-SC2-CN2-\*\*\*  
22 44  
33 55

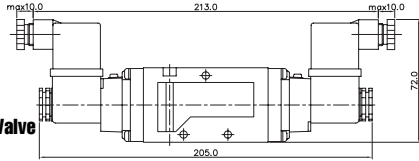

## 5Port 3Position Solenoid Valve

Exhaust Center  
SF5403-IP-SC2-CN2-\*\*\*  
2 4  
3 1 5

Pressure Center  
SF5503-IP-SC2-CN2-\*\*\*  
2 4  
3 1 5

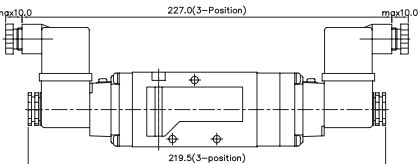

## 3Port 2Position Solenoid Valve

Normally Closed  
SF5601-IP-SD2-\*\*\*  
2  
1 3

Normally Closed  
SF5701-IP-SD2-\*\*\*  
2  
1 3

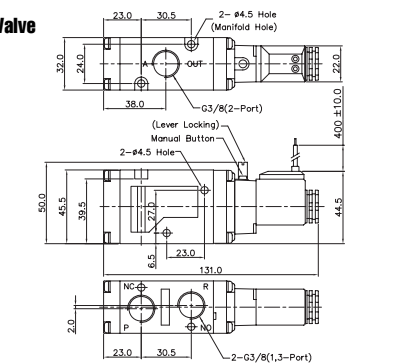

## 5Port 2Position Pneumatic Valve

Single Pneumatic  
SFP5101  
2 4  
3 1 5

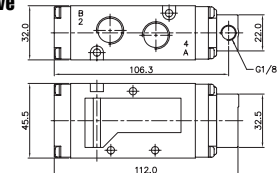

Double Pneumatic  
SFP5200  
2 4  
3 1 5

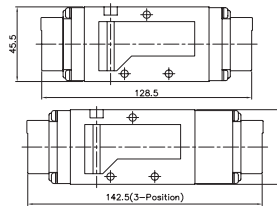

## 5Port 3Position Pneumatic Valve

Closed Center  
SFP5303  
2 4  
3 1 5

Exhaust Center  
SFP5403  
2 4  
3 1 5

Pressure Center  
SFP5503  
2 4  
3 1 5

## 3Port 2Position Pneumatic Valve

Single Pneumatic  
SFP5601  
2  
1 3

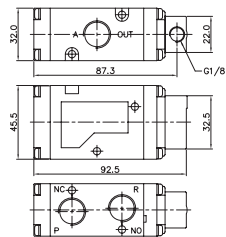

# MF5000 MANIFOLD BLOCK

(SF5000 Solenoid & Pneumatic Valve Use)

## Manifold Block Ordering Code

MF 5500 - 2

Series	Manifold Station
MF5500	5 Way
MF5300	3 Way

02	2-Station
04	4-Station
06	6-Station
08	8-Station
10	10-Station

## Blanking Plate Ordering Code

MF5500-BLK

Blanking Plate.  
(Material: SCP1)

Manifold Gasket.  
(Material: NBR)

MF5300-BLK

Blanking Plate.  
(Material: SCP1)

Manifold Gasket.  
(Material: NBR)

## 5-Port Manifold Block

MF5500-4

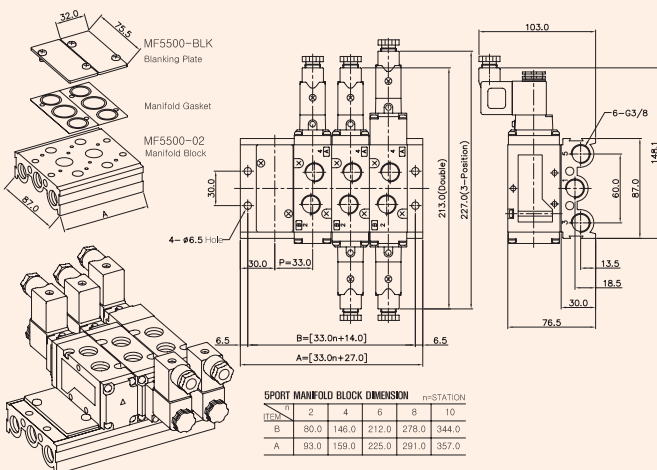

## 3-Port Manifold Block

MF5300-4

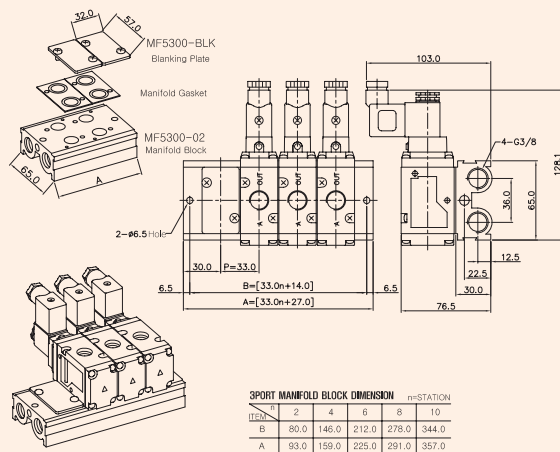

# SF6000. 1/2

"F" FLEXIBLE Series  
Solenoid / Pneumatic Valves

- 5/2, 5/3 - 1/2
- 36mm Body Width
- Transition Flow 3500ℓ/min (5bar)

## SPECIFICATION

ITEM	SERIES	SOLENOID, PNEUMATIC	
		5 Port 2 Position	5 Port 3 Position
Fluids		Compressed Air & Inert Gases	
Pressure(bar)		1.5~10.0	2.0~10.0
Eff. Section Area(mm <sup>2</sup> )-5bar		65.0	50.0
Ambient & Fluid Temp.		5~60°C (41~140°F)	
Response Time(5bar)		30ms or Less	40ms or Less
Max. Working Frequency		2c/sec	1c/sec
Lubrication		Not Required(Use ISO VG32 #)	
Manual Override		Push Button(Standard), Lever Lock(Option)	
Coil Insulation Class		F-Class or Equivalent	
Permissible Voltage Variation		±10% of Rated Voltage	
Off Min. Residual Voltage		AC:20% or Less / DC:10% or Less	
Power Consumption		Holding-AC:5.5VA(60Hz) / DC:2.5W	

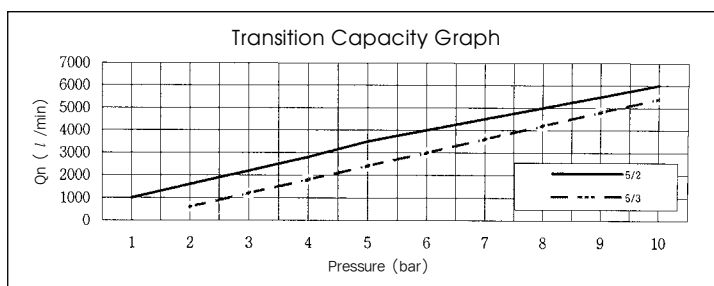

## The Material of Parts

- Valve Body : Die-Cast Aluminium
- Spool : Aluminium
- Seals : NBR
- Spring : Stainless
- Cap : Zinc Pressure Die-Cast
- Pilot Parts : Glass Filled Nylon
- Armature : Stainless Steel
- Armature Seals : Viton

\* The specification on each item can be amended without any prenotice to improve a performance.  
\* The specification on each item can be different from actual specification.

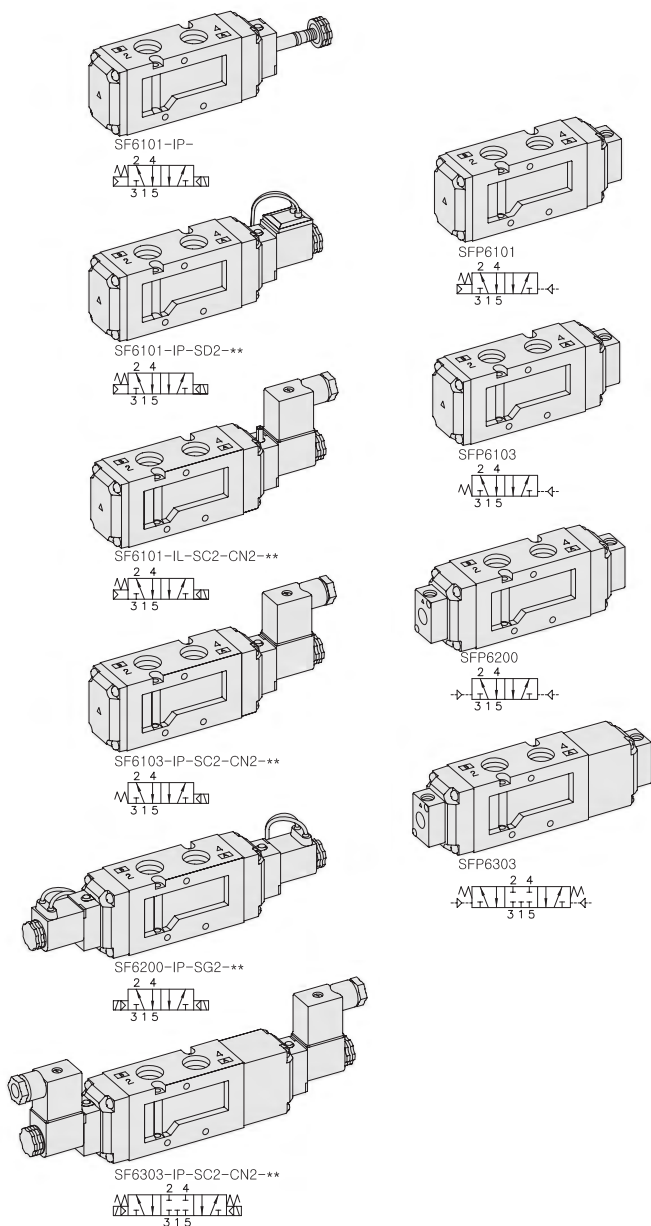

\*\* : Voltage Selection (see page 80)

## ORDERING NO.

**SF6 1 0 1 - I P - SC2 - CN2 - A2**

Valve Series	Function	Port Size & Thread	Return Method	Int/Ext. Pilot	Manual Operator	Solenoid Coil Type	Connector Type	Voltage
SF6 : Solenoid Valve	1 5/2 Single	0 G 1/2	0 None	1 Internal Pilot	0 None	0 None	0 None	0 None
	2 5/2 Double	1 NPT 1/2	1 Air + Spring		P Push Non-Locking	SC2 3 Pin Connector Coil	CN2 Normal Connector	A2 AC 220V
	3 5/3 Closed Center		2 Air		L Lever Locking	SG2 Grommet/Flying Leads	CD2 Connector With LED	A1 AC 110V
	4 5/3 Open Center		3 Spring			SD2 Grommet/Flying Leads With LED	C22 Connector With LED & Surge Suppressor	A4 AC 24V
SFP6 : Pneumatic Valve	5 5/3 Pressure Center						D4 DC 24V	D2 DC 12V



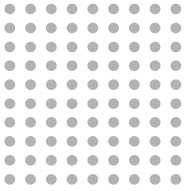

# Solenoid & Pilot Actuated Spool Valves

Port Thread 1/2

## 5Port 2Position Solenoid Valve

Single Solenoid  
SF6101-IP-SD2-\*

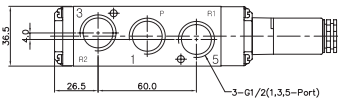
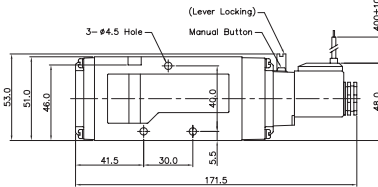
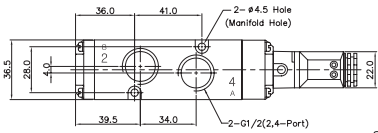
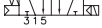

Double Solenoid  
SF6200-IP-SC2-CN2-\*

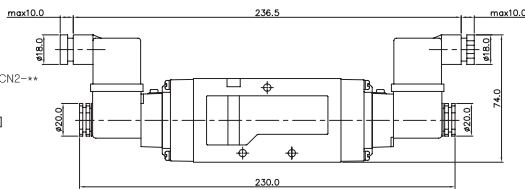

## 5Port 3Position Solenoid Valve

Closed Center

SF6303-IP-SC2-CN2-\*

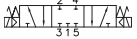

Exhaust Center

SF6403-IP-SC2-CN2-\*

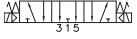

Pressure Center

SF6503-IP-SC2-CN2-\*

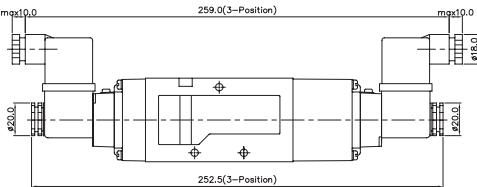
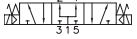

## 5Port 2Position Pneumatic Valve

Single Pneumatic  
SFP6101

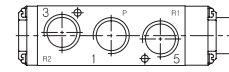
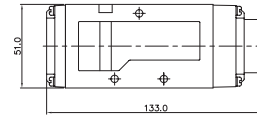
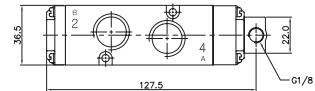
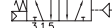

Double Pneumatic  
SFP6200

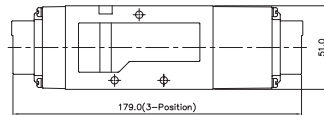
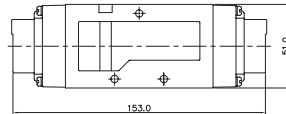
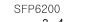

## 5Port 3Position Pneumatic Valve

Closed Center

SFP6303

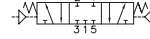

Exhaust Center

SFP6403

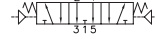

Pressure Center

SFP6503

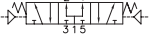

## Manifold Block Ordering Code

MF 6500		-		2	
Series	Manifold Station				
MF6500	5 Way	02	2-Station		
		04	4-Station		
		06	6-Station		
		08	8-Station		
		10	10-Station		

## Blanking Plate Ordering Code

MF6500-BLK

Blanking Plate.  
(Material: SCP1)

Gasket O-Ring  
(Material: NBR)

# MF6000 MANIFOLD BLOCK

(SF6000 Solenoid & Pneumatic Valve Use)

## 5-Port Manifold Block

MF6500-4

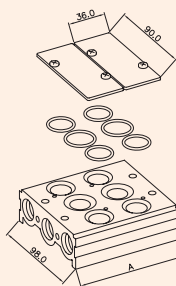

MF6500-BLK  
Blanking Plate  
Gasket O-Ring

MF6500-02  
Manifold Block

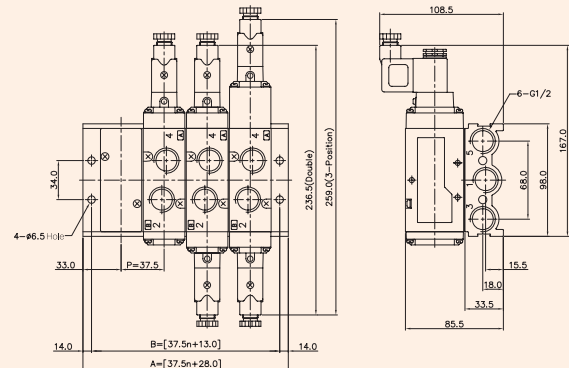
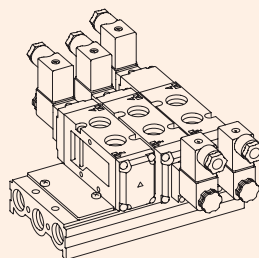

5PORT MANIFOLD BLOCK DIMENSION		n=STATION	
ITEM	2	4	6
B	88.0	163.0	238.0
A	103.0	178.0	253.0





# SIV·SIE (ISO) Series

## 5/2, 5/3 Solenoid, Pneumatic Valve

### CHAPTER 04

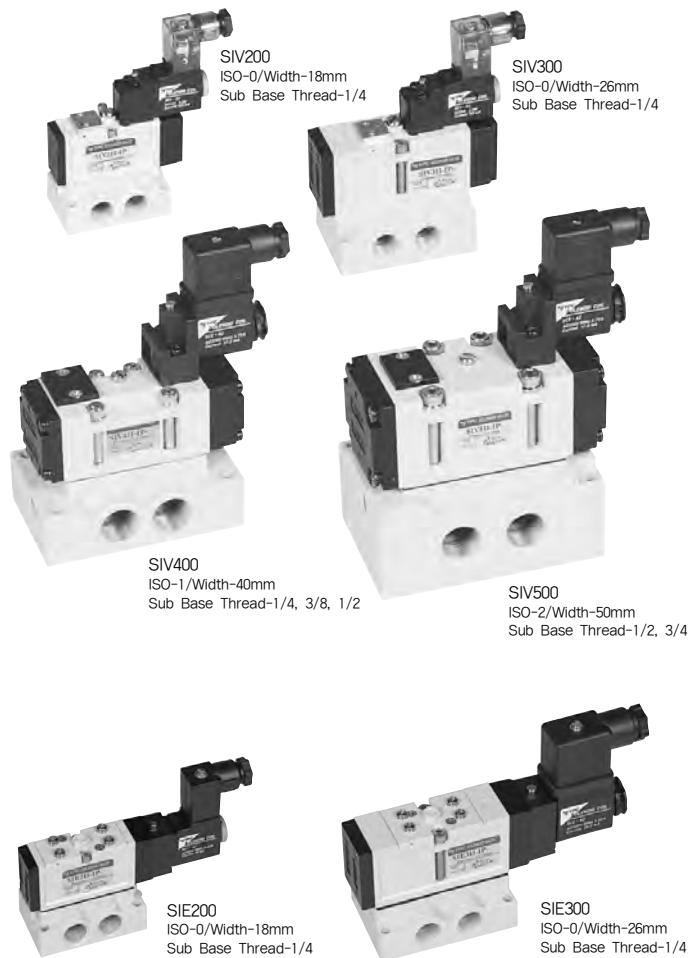

- SIV200
- SIV300
- SIV400
- SIV500

- SIE 200
- SIE 300

# SIV200

ISO-0 15407-1 / VDMA 24563  
Solenoid / Pneumatic Valves

- 5/2, 5/3
- 18mm Body Width
- Sub-Base or Manifold Mounting Type
- Transition Flow 700ℓ/min (5bar)

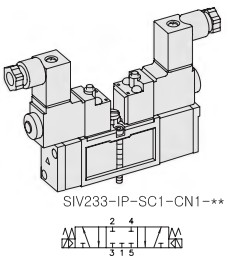
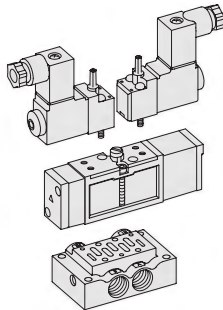
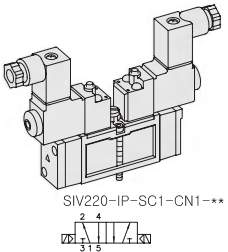
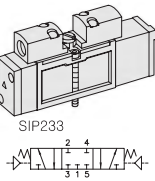
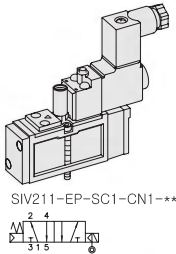
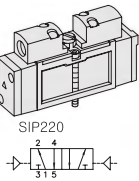
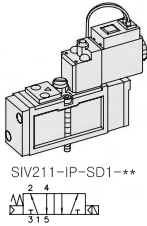
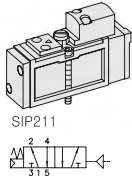
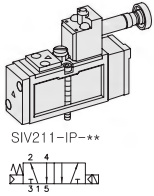

\*\* : Voltage Selection (see page 80)

## SPECIFICATION

ITEM	SERIES	SOLENOID, PNEUMATIC	
		5 Port 2 Position	5 Port 3 Position
Fluids		Compressed Air & Inert Gases	
Pressure(bar)		1.5~10.0	2.0~10.0
Eff. Section Area(mm <sup>2</sup> )-5bar		12.0	8.5
Ambient & Fluid Temp.		5~60°C (41~140°F)	
Response Time(5bar)		25ms or Less	35ms or Less
Max. Working Frequency		5c/sec	3c/sec
Lubrication		Not Required(Use ISO VG32 #)	
Manual Override		Push Button(Standard), Lever Lock(Option)	
Coil Insulation Class		F-Class or Equivalent	
Permissible Voltage Variation		±10% of Rated Voltage	
Off Min. Residual Voltage		AC:20% or Less / DC:10% or Less	
Power Consumption		Holding-AC:3.5VA(60Hz) / DC:2.5W	

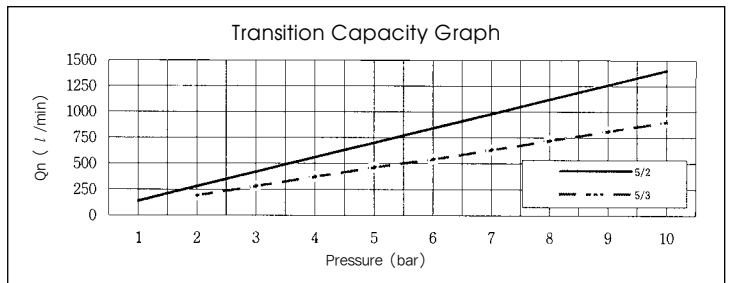

- ### The Material of Parts
- Valve Body : Die-Cast Aluminium
  - Spool : Aluminium
  - Seals : NBR
  - Spring : Stainless
  - Cap : Zinc Pressure Die-Cast
  - Pilot Parts : Glass Filled Nylon
  - Armature : Stainless Steel
  - Armature Seals : Viton

\* The specification on each item can be amended without any prenotice to improve a performance.  
\* The specification on each item can be different from actual specification.

## ORDERING NO.

**SIV2 1 1 - I P - SC1 - CN1 - A2**

Valve Series	Function	Return Method	Int/Ext. Pilot	Manual Operator	Solenoid Coil Type	Connector Type	Voltage
SIV2 : Solenoid Valve	1	5/2 Single	0 None	I Internal Pilot	0 None	0 None	0 None
	2	5/2 Double	1 Air + Spring	E External Pilot	P Push Non-Locking	CN1 Normal Connector	A2 AC 220V
	3	5/3 Closed Center	2 Air		L Lever Locking	SG1 Grommet/Flying Leads	A1 AC 110V
SIP2 : Pneumatic Valve	4	5/3 Open Center	3 Spring		SD1 Grommet/Flying Leads With LED	CZ1 Connector With LED & Surge Suppressor	A4 AC 24V
	5	5/3 Pressure Center			SL1 90 Degree Plug-in Wire Assembly With LED		D4 DC 24V
					SM1 180 Degree Plug-in Wire Assembly With LED		D2 DC 12V

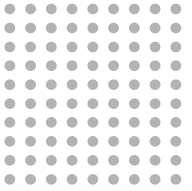

# Solenoid & Pilot Actuated Spool Valves

## 18mm Body Width

### 5Port 2Position Solenoid Valve

Single Solenoid  
SIV211-IP-SG1-\*\*\*



External Pilot  
SIV211-EP-SG1-\*\*\*

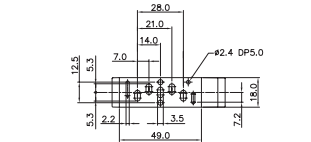
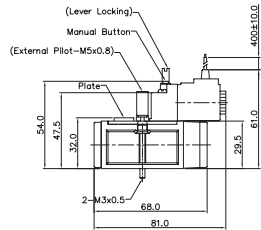
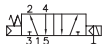

Double Solenoid  
SIV220-IP-SC1-CN1-\*\*\*

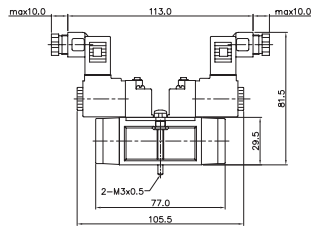
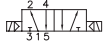

### 5Port 3Position Solenoid Valve

Closed Center  
SIV233-IP-SC1-CN1-\*\*\*

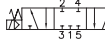

Exhaust Center  
SIV243-IP-SC1-CN1-\*\*\*

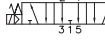

Pressure Center  
SIV253-IP-SC1-CN1-\*\*\*

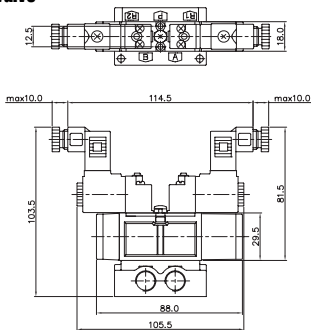

### 5Port 2Position Pneumatic Valve

Single Pneumatic  
SIP211

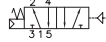

Double Pneumatic  
SIP220

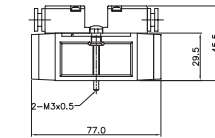
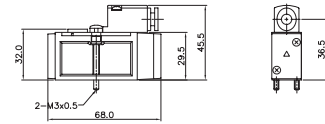
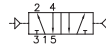

### 5Port 3Position Pneumatic Valve

Closed Center  
SIP233

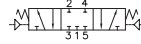

Exhaust Center  
SIP243

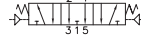

Pressure Center  
SIP253

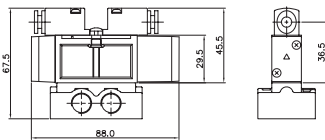
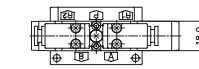
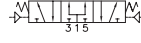

### Sub Base Ordering Code

SIB2 1 - S		
Base Series	Port & Thread	Function
SIB2	0 None	S Single Station Sub Base, 1/4 Port Without Pilot Ports
SIV200 Solenoid Valve	1 G	SP Single Station Sub Base, 1/4 Port With Pilot Ports
	2 NPT	DB Single Station Sub Base, 1/8 Port Without Pilot Ports
		DC6 Double Modular Sub Base, Ø6 One-Touch Fitting
		E End Cover, 1/8 Port
		EB End Blanking Cover

## SIB20 SINGLE, DOUBLE SUB BASE

(SIV200 Solenoid & Pneumatic Valve Use Sub Base)

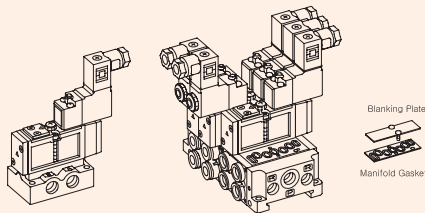

### Single Station Sub Base Dimension

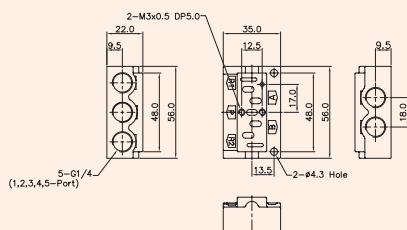

### Double Modular Sub Base Dimension

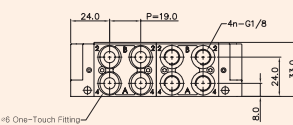
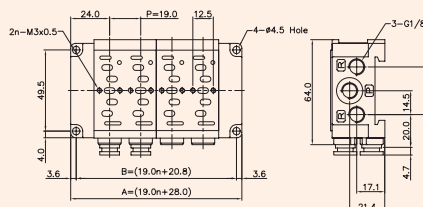

DOUBLE MODULAR SUB BASE DIMENSION		n-STATION			
ITEM	2	4	6	8	10
B	58.8	96.8	134.8	172.8	210.8
A	66.0	104.0	142.0	180.0	218.0

Ordering Code SIB20-BLK		Blanking Plate (Material: STS304)
		Manifold Gasket. (Material: NBR)
Ordering Code SIB21-E		End Cover, 1/8 (Material: AI)
Ordering Code SIB20-EB		End Blanking Cover (Material: AI)
Ordering Code SIB21-DB		Double Modular Sub Base, 1/8 (Material: AI)
Ordering Code SIB20-DC6		Double Modular Sub Base Ø6 one-touch fitting (Material: AI)

# SIV300

ISO-0 15407-1 / VDMA 24563  
Solenoid / Pneumatic Valves

- 5/2, 5/3
- 26mm Body Width
- Sub-Base or Manifold Mounting Type
- Transition Flow 1000ℓ/min (5bar)

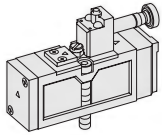

SIV311-IP-\*\*\*

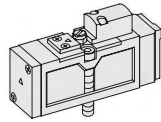

SIP311

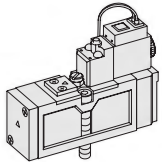

SIV311-IP-SD1-\*\*\*

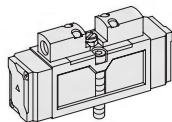

SIP320

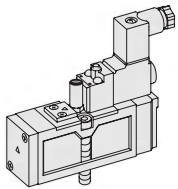

SIV311-EP-SC1-CN1-\*\*\*

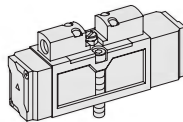

SIP333

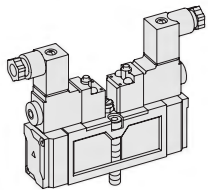
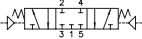

SIV320-IP-SC1-CN1-\*\*\*

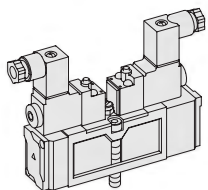
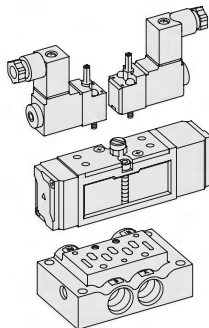

SIV333-IP-SC1-CN1-\*\*\*

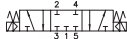

\*\* : Voltage Selection (see page 80)

## SPECIFICATION

ITEM	SERIES	SOLENOID, PNEUMATIC	
		5 Port 2 Position	5 Port 3 Position
Fluids		Compressed Air & Inert Gases	
Pressure(bar)		1.5~10.0	2.0~10.0
Eff. Section Area(mm <sup>2</sup> )-5bar		18.0	11.0
Ambient & Fluid Temp.		5~60°C (41~140°F)	
Response Time(5bar)		25ms or Less	35ms or Less
Max. Working Frequency		5c/sec	3c/sec
Lubrication		Not Required(Use ISO VG32 #)	
Manual Override		Push Button(Standard), Lever Lock(Option)	
Coil Insulation Class		F-Class or Equivalent	
Permissible Voltage Variation		±10% of Rated Voltage	
Off Min. Residual Voltage		AC:20% or Less / DC:10% or Less	
Power Consumption		Holding-AC:3.5VA(60Hz) / DC:2.5W	

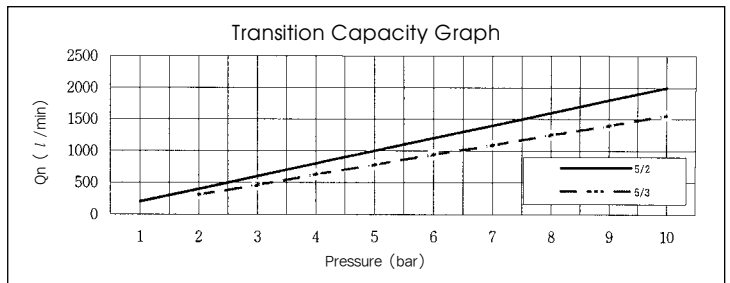

## The Material of Parts

- Valve Body : Die-Cast Aluminium
- Spool : Aluminium
- Seals : NBR
- Spring : Stainless
- Cap : Zinc Pressure Die-Cast
- Pilot Parts : Glass Filled Nylon
- Armature : Stainless Steel
- Armature Seals : Viton

※ The specification on each item can be amended without any prenotice to improve a performance.  
 ※ The specification on each item can be different from actual specification.

## ORDERING NO.

**SIV3 1 1 - I P - SC1 - CN1 - A2**

Valve Series	Function	Return Method	Int/Ext. Pilot	Manual Operator	Solenoid Coil Type	Connector Type	Voltage
SIV3 : Solenoid Valve	1	5/2 Single	0 None	I Internal Pilot	0 None	0 None	0 None
	2	5/2 Double	1 Air + Spring	E External Pilot	P Push Non-Locking	CN1 Normal Connector	A2 AC 220V
	3	5/3 Closed Center	2 Air		L Lever Locking	SG1 Grommet/Flying Leads	A1 AC 110V
SIP3 : Pneumatic Valve	4	5/3 Open Center	3 Spring		SD1 Grommet/Flying Leads With LED	CZ1 Connector With LED & Surge Suppressor	A4 AC 24V
	5	5/3 Pressure Center			SL1 90 Degree Plug-in Wire Assembly With LED		D4 DC 24V
					SM1 180 Degree Plug-in Wire Assembly With LED		D2 DC 12V

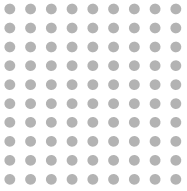

# Solenoid & Pilot Actuated Spool Valves

# 26mm Body Width

## 5Port 2Position Solenoid Valve

Single Solenoid  
SIV311-IP-SG1-\*\*\*



External Pilot  
SIV311-EP-SG1-\*\*\*

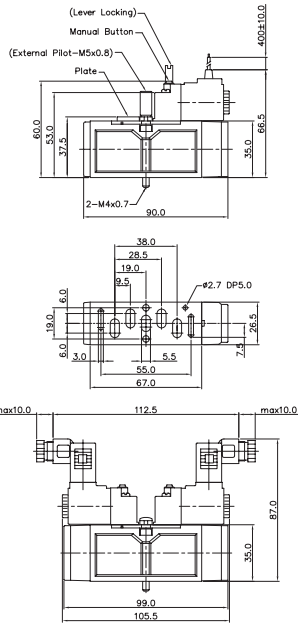
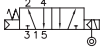

Double Solenoid  
SIV320-IP-SC1-CN1-\*\*\*

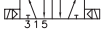

## 5Port 2Position Pneumatic Valve

Single Pneumatic  
SIP311



Double Pneumatic  
SIP320

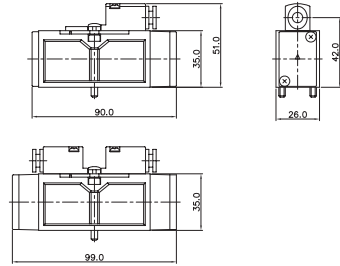

## 5Port 3Position Pneumatic Valve

Closed Center  
SIP333

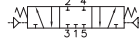

Exhaust Center  
SIP343

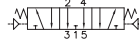

Pressure Center  
SIP353

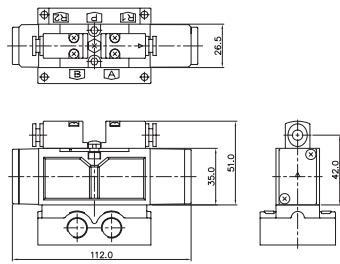
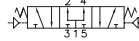

## 5Port 3Position Solenoid Valve

Closed Center  
SIV333-IP-SC1-CN1-\*\*\*

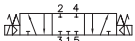

Exhaust Center  
SIV343-IP-SC1-CN1-\*\*\*



Pressure Center  
SIV353-IP-SC1-CN1-\*\*\*

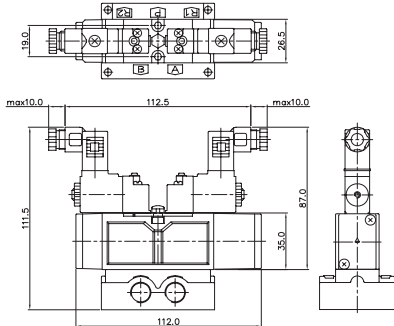
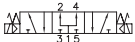

## Sub Base Ordering Code

SIB3			1		S	
Base Series	Port & Thread		Function			
SIB3	0	None	S	Single Station Sub Base, 1/4 Port Without Pilot Ports		
SIV300 Solenoid Valve	1	G	SP	Single Station Sub Base, 1/4 Port With Pilot Ports		
	2	NPT	DB	Double Modular Sub Base, 1/4 Port Without Pilot Ports		
			DC8	Double Modular Sub Base, Ø8 One-Touch Fitting		
			E	End Cover, 1/4 Port		
			EB	End Blanking Cover		

## SIB30 SINGLE, DOUBLE SUB BASE

(SIV300 Solenoid & Pneumatic Valve Use Sub Base)

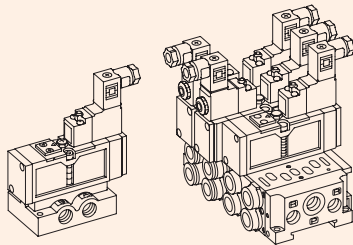

### Single Station Sub Base Dimension

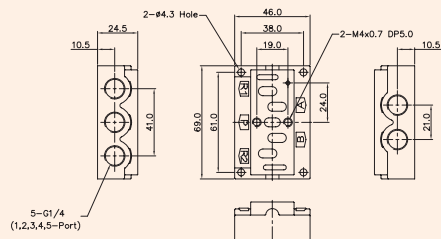

### Double Modular Sub Base Dimension

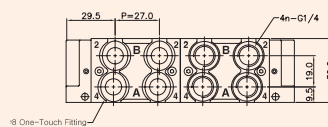
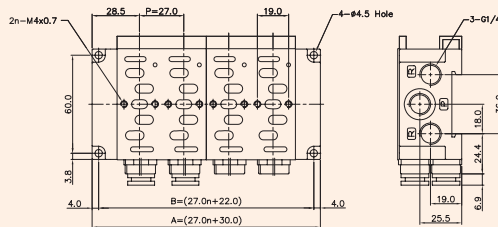

DOUBLE MODULAR SUB BASE DIMENSION					n*STATION
ITEM	2	4	6	8	
A	76.0	130.0	184.0	238.0	292.0
B	84.0	138.0	192.0	246.0	300.0

Ordering Code SIB30-BLK		Blanking Plate (Material: STS304)
Ordering Code SIB31-E		End Cover, 1/4 (Material: Al)
Ordering Code SIB30-EB		End Blanking Cover (Material: Al)
Ordering Code SIB31-DB		Double Modular Sub Base, 1/4 (Material: Al)
Ordering Code SIB30-DC8		Double Modular Sub Base Ø8 one-touch fitting (Material: Al)

# SIV400

ISO-1

Solenoid / Pneumatic Valves

- 5/2, 5/3
- 40mm Body Width
- 30mm CNOMO pilot
- Sub-Base Mounting Type
- Transition Flow 1600ℓ/min (5bar)

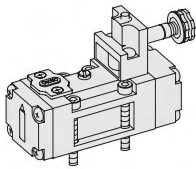

SIV411-IP-\*\*\*

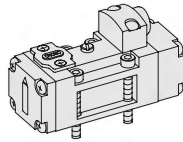

SIP411

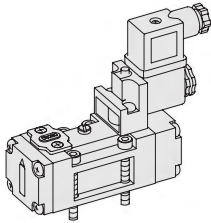

SIV411-EP-SC2-CN2-\*\*\*

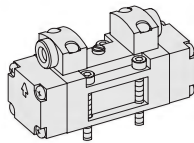

SIP420

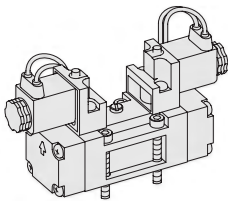

SIV420-IP-SG2-\*\*\*

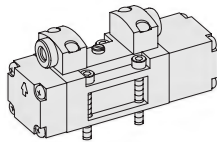

SIP433

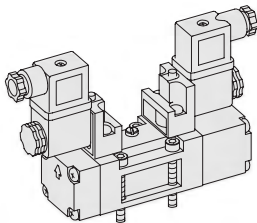

SIV433-IP-SC2-CN2-\*\*\*

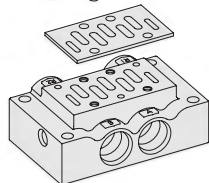
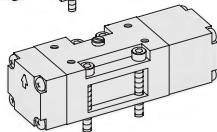
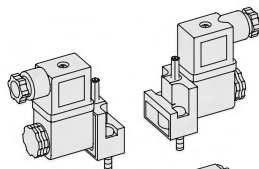

\*\*\*: Voltage Selection (see page 80)

## SPECIFICATION

ITEM	SERIES	SOLENOID, PNEUMATIC	
		FUNCTION	
		5 Port 2 Position	5 Port 3 Position
Fluids		Compressed Air & Inert Gases	
Pressure(bar)		1.5~10.0	2.0~10.0
Eff. Section Area(mm <sup>2</sup> )-5bar		30.0	25.0
Ambient & Fluid Temp.		5~60°C (41~140°F)	
Response Time(5bar)		30ms or Less	40ms or Less
Max. Working Frequency		3c/sec	1c/sec
Lubrication		Not Required(Use ISO VG32 #)	
Manual Override		Push Button(Standard), Lever Lock(Option)	
Coil Insulation Class		F-Class or Equivalent	
Permissible Voltage Variation		±10% of Rated Voltage	
Off Min. Residual Voltage		AC:20% or Less / DC:10% or Less	
Power Consumption		Holding-AC:5.5VA(60Hz) / DC:2.5W	

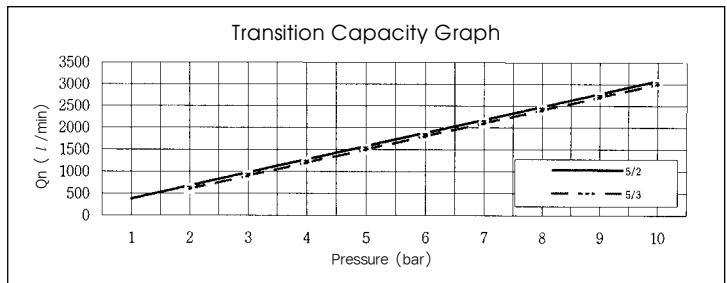

## The Material of Parts

- Valve Body : Die-Cast Aluminium
- Spool : Aluminium
- Seals : NBR
- Spring : Stainless
- Cap : Zinc Pressure Die-Cast
- Pilot Parts : Glass Filled Nylon
- Armature : Stainless Steel
- Armature Seals : Viton

\* The specification on each item can be amended without any prenotice to improve a performance.  
 \* The specification on each item can be different from actual specification.

## ORDERING NO.

**SIV4 1 1 - I P - SC2 - CN2 - A2**

Valve Series	Function	Return Method	Int/Ext. Pilot	Manual Operator	Solenoid Coil Type	Connector Type	Voltage
SIV4 : Solenoid Valve	1	5/2 Single	0 None	I Internal Pilot	0 None	0 None	0 None
	2	5/2 Double	1 Air + Spring	P Push Non-Locking	SC2 3 Pin Connector Coil	CN2 Normal Connector	A2 AC 220V
	3	5/3 Closed Center	2 Air	E External Pilot	L Lever Locking	SG2 Grommet/Flying Leads	CD2 Connector With LED
SIP4 : Pneumatic Valve	4	5/3 Open Center	3 Spring		SD2 Grommet/Flying Leads With LED	CZ2 Connector With LED & Surge Suppressor	A4 AC 24V
	5	5/3 Pressure Center					D4 DC 24V
							D2 DC 12V



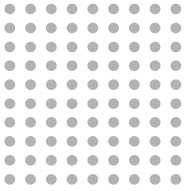

# Solenoid & Pilot Actuated Spool Valves

## 40mm Body Width

### 5Port 2Position Solenoid Valve

Single Solenoid  
SIV411-IP-SD2-\*\*\*

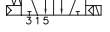

External Pilot  
SIV411-EP-SD2-\*\*\*

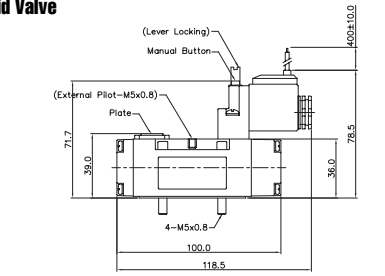
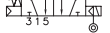

Double Solenoid  
SIV420-IP-SC2-CN2-\*\*\*

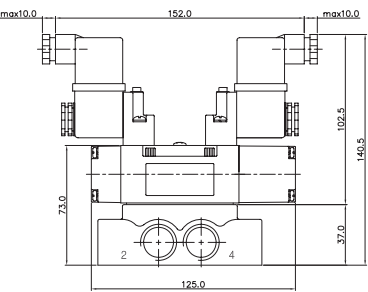
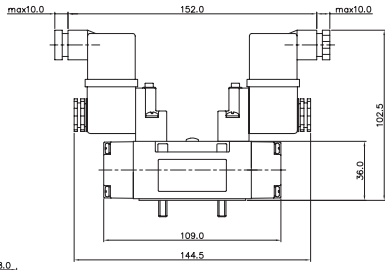
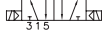

### 5Port 2Position Pneumatic Valve

Single Pneumatic  
SIP411

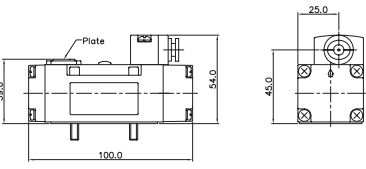

Double Pneumatic  
SIP420

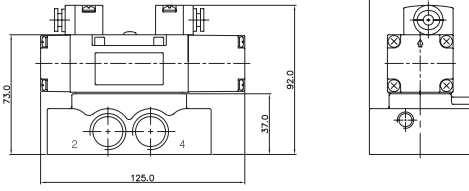
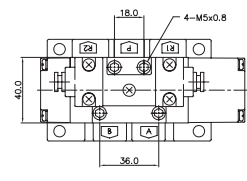
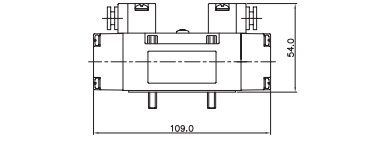
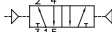

### 5Port 3Position Pneumatic Valve

Closed Center  
SIP433



Exhaust Center  
SIP443

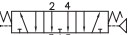

Pressure Center  
SIP453

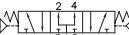

### 5Port 3Position Solenoid Valve

Closed Center  
SIV433-IP-SC2-CN2-\*\*\*

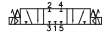

Exhaust Center  
SIV443-IP-SC2-CN2-\*\*\*



Pressure Center  
SIV453-IP-SC2-CN2-\*\*\*

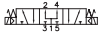

## SIB40 SINGLE SUB BASE

(SIV400 Solenoid & Pneumatic Valve Use Sub Base)

### Single Station Sub Base Dimension

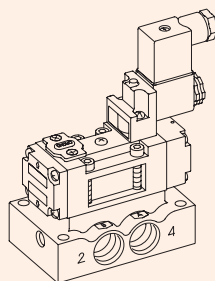

Sub Base Gasket  
(Material: NBR)

Sub Base  
(Material: Al)

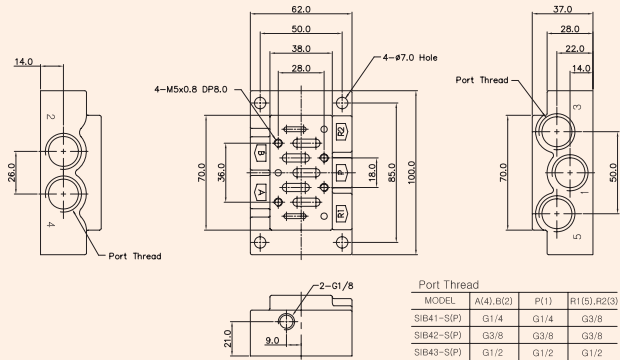

MODEL	A(4),B(2)	P(1)	R(1),R2(3)
SIB41-S(P)	G1/4	G1/4	G3/8
SIB42-S(P)	G3/8	G3/8	G3/8
SIB43-S(P)	G1/2	G1/2	G1/2

### Sub Base Ordering Code

Base Series	Port & Thread	Function
SIB4	0 None	S Single Station Sub Base, Without Pilot Ports
SIV400 Solenoid Valve	1 G 1/4	SP Single Station Sub Base, With Pilot Ports
	2 G 3/8	
	3 G 1/2	
	6 NPT 1/4	
	7 NPT 3/8	
	8 NPT 1/2	

# SIV500

ISO-2

Solenoid / Pneumatic Valves

- 5/2, 5/3
- 50mm Body Width
- 30mm CNOMO PILOT
- Sub-Base Mounting Type
- Transition Flow 3500ℓ/min (5bar)

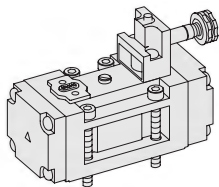

SIV511-IP-\*\*\*

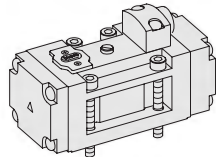

SIP511

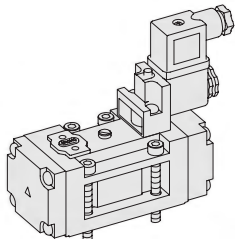
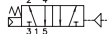

SIV511-EP-SC2-CN2-\*\*\*

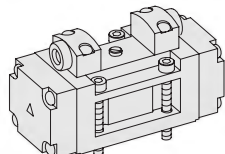

SIP520

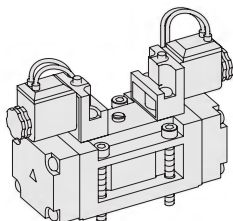
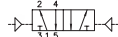

SIV520-IP-SD2-\*\*\*

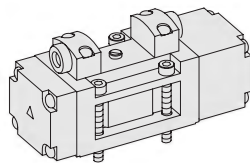

SIP533

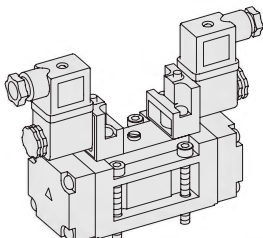
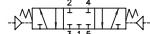

SIV533-IP-SC2-CN2-\*\*\*

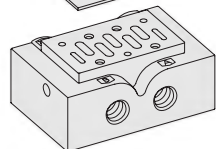
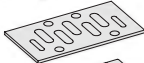
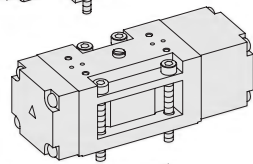
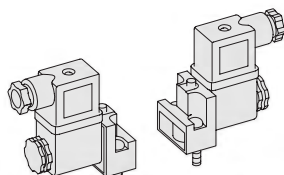
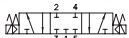

\*\* : Voltage Selection (see page 80)

## SPECIFICATION

ITEM	SERIES	SOLENOID, PNEUMATIC	
		5 Port 2 Position	5 Port 3 Position
Fluids		Compressed Air & Inert Gases	
Pressure(bar)		1.5~10.0	2.0~10.0
Eff. Sectional Area(mm <sup>2</sup> )-5bar		65.0	50.0
Ambient & Fluid Temp.		5~60°C (41~140°F)	
Response Time(5bar)		35ms or Less	45ms or Less
Max. Working Frequency		3c/sec	1c/sec
Lubrication		Not Required(Use ISO VG32 #)	
Manual Override		Push Button(Standard), Lever Lock(Option)	
Coil Insulation Class		F-Class or Equivalent	
Permissible Voltage Variation		±10% of Rated Voltage	
Off Min. Residual Voltage		AC:20% or Less / DC:10% or Less	
Power Consumption		Holding-AC:5.5VA(60Hz) / DC:2.5W	

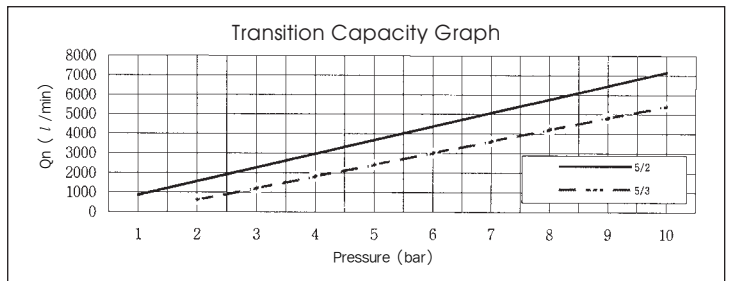

## The Material of Parts

- Valve Body : Die-Cast Aluminium
- Spool : Aluminium
- Seals : NBR
- Spring : Stainless
- Cap : Zinc Pressure Die-Cast
- Pilot Parts : Glass Filled Nylon
- Armature : Stainless Steel
- Armature Seals : Viton

\* The specification on each item can be amended without any prenotice to improve a performance.  
 \* The specification on each item can be different from actual specification.

## ORDERING NO.

**SIV5 1 1 - I P - SC2 - CN2 - A2**

Valve Series	Function	Return Method	Int/Ext. Pilot	Manual Operator	Solenoid Coil Type	Connector Type	Voltage	
SIV5 : Solenoid Valve	1	5/2 Single	0 None	I Internal Pilot	0 None	0 None	0 None	
	2	5/2 Double	1 Air + Spring	P Push Non-Locking	SC2 3 Pin Connector Coil	CN2 Normal Connector	A2 AC 220V	
	3	5/3 Closed Center	2 Air	E External Pilot	L Lever Locking	SG2 Grommet/Flying Leads	CD2 Connector With LED	A1 AC 110V
	4	5/3 Open Center	3 Spring			SD2 Grommet/Flying Leads	CZ2 Connector With LED & Surge Suppressor	A4 AC 24V
SIP5 : Pneumatic Valve	5	5/3 Pressure Center			With LED		D4 DC 24V	
							D2 DC 12V	

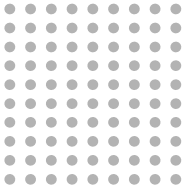

# Solenoid & Pilot Actuated Spool Valves

## 50mm Body Width

### 5Port 2Position Solenoid Valve

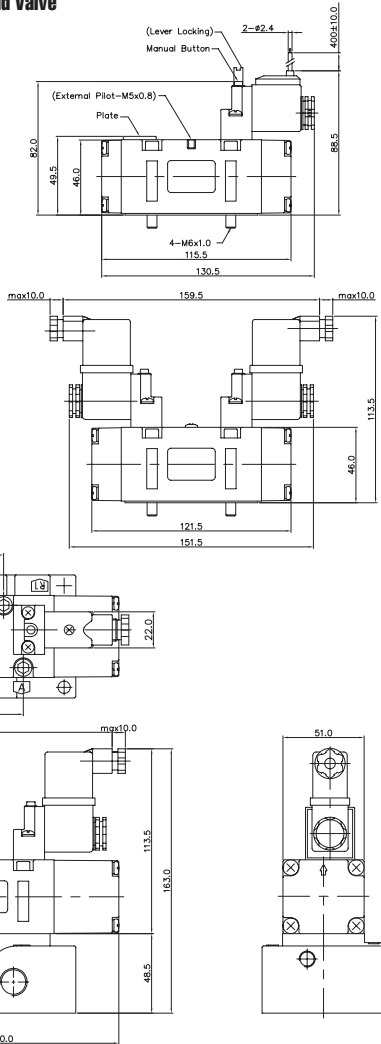
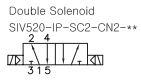
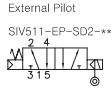
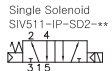

### 5Port 3Position Solenoid Valve

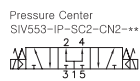
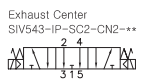
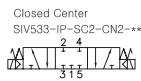

### 5Port 2Position Pneumatic Valve

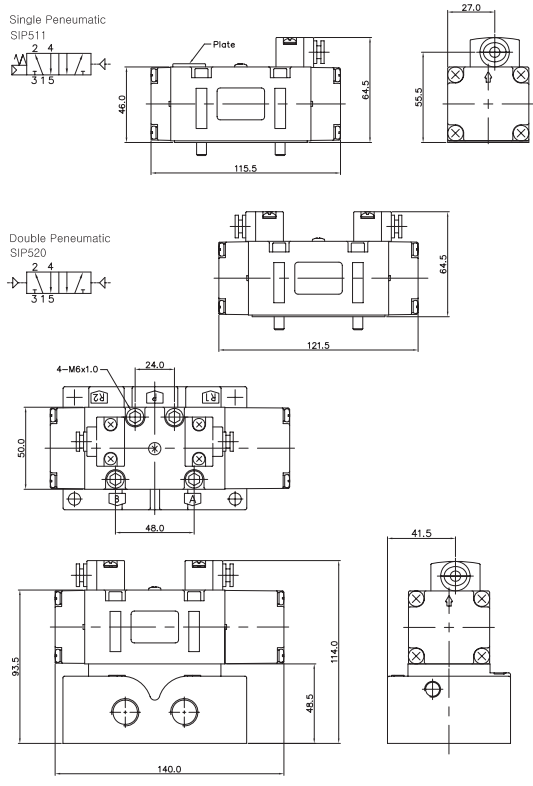
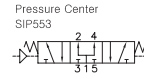
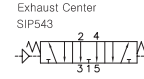
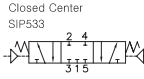
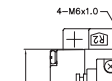
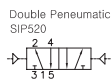
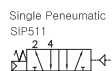

### 5Port 3Position Pneumatic Valve

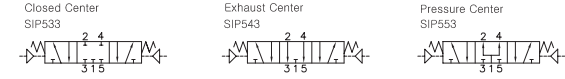

### Sub Base Ordering Code

Sub Base Series	Port & Thread	Function
SIB5	0 None	S Single Station Sub Base, Without Pilot Ports
SIV500 Solenoid Valve	2 G 3/8	SP Single Station Sub Base, With Pilot Ports
	3 G 1/2	
	4 G 3/4	
	7 NPT 3/8	
	8 NPT 1/2	
	9 NPT 3/4	

## SIB50 SINGLE SUB BASE

(SIV500 Solenoid & Pneumatic Valve Use Sub Base)

### Single Station Sub Base Dimension

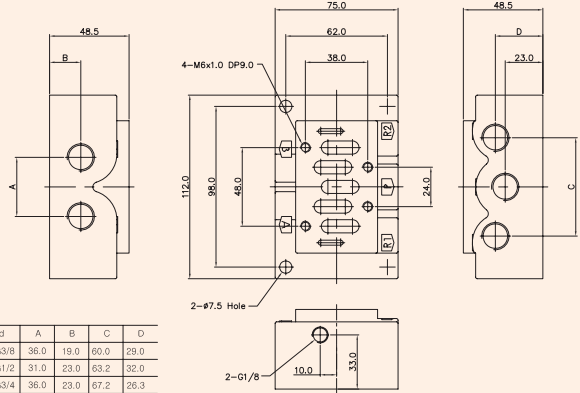
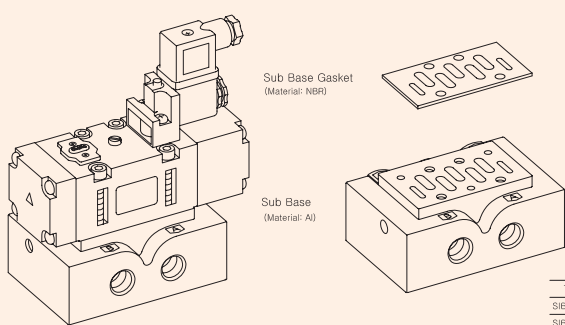

Thread	A	B	C	D
SIB52-G3/8	36.0	19.0	60.0	29.0
SIB53-G1/2	31.0	23.0	63.2	32.0
SIB54-G3/4	36.0	23.0	67.2	26.3

# SIE200

"E" ECONOMY Series  
Solenoid / Pneumatic Valves

- 5/2, 5/3
- 18mm Body Width
- Sub-Base or Manifold Mounting Type
- Transition Flow 700ℓ/min (5bar)

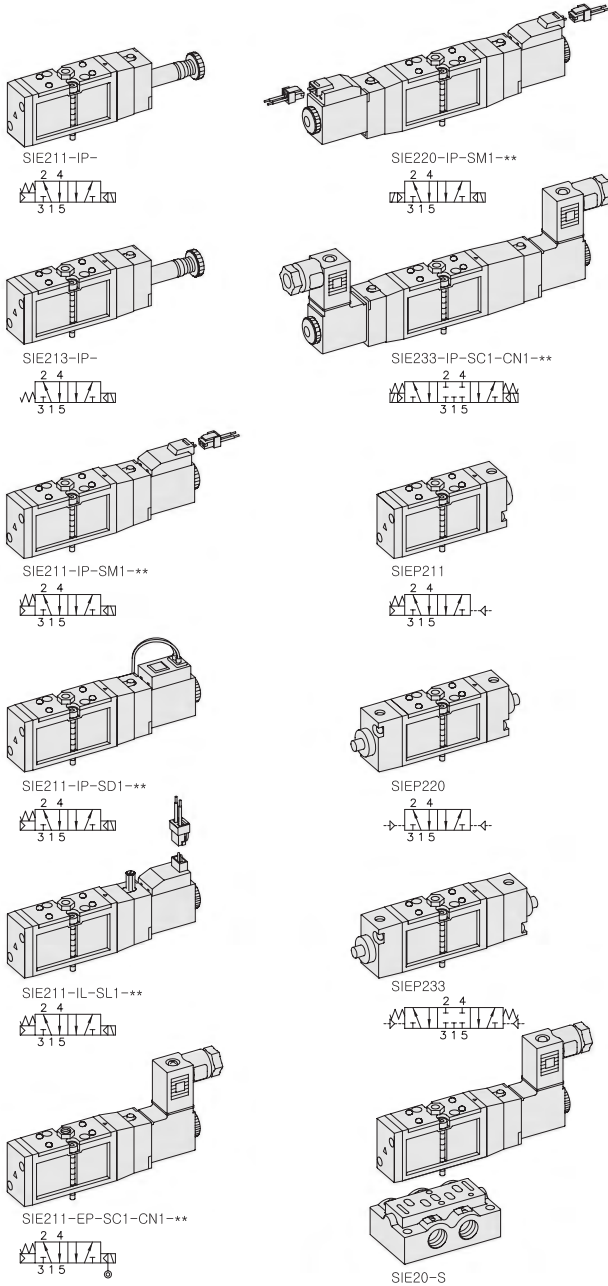

\*\* : Voltage Selection (see page 80)

## SPECIFICATION

ITEM	SERIES	SOLENOID, PNEUMATIC	
		5 Port 2 Position	5 Port 3 Position
Fluids		Compressed Air & Inert Gases	
Pressure(bar)		1.5~10.0	2.0~10.0
Eff. Sectional Area(mm <sup>2</sup> )-5bar		12.0	8.5
Ambient & Fluid Temp.		5~60°C (41~140°F)	
Response Time(5bar)		25ms or Less	35ms or Less
Max. Working Frequency		5c/sec	3c/sec
Lubrication		Not Required(Use ISO VG32 #)	
Manual Override		Push Button(Standard), Lever Lock(Option)	
Coil Insulation Class		F-Class or Equivalent	
Permissible Voltage Variation		±10% of Rated Voltage	
Off Min. Residual Voltage		AC:20% or Less / DC:10% or Less	
Power Consumption		Holding-AC:3.5VA(60Hz) / DC:2.5W	

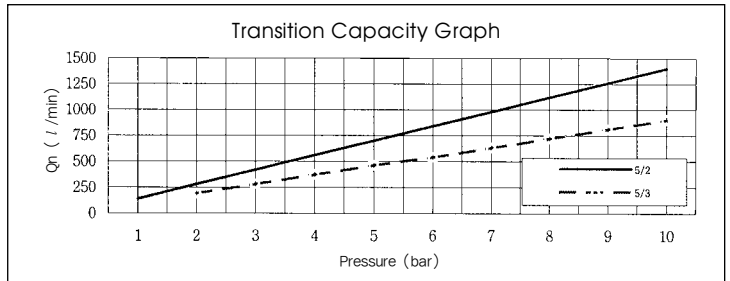

### The Material of Parts

■ Valve Body : Die-Cast Aluminium	■ Pilot Parts : Glass Filled Nylon
■ Spool : Aluminium	■ Armature : Stainless Steel
■ Seals : NBR	■ Armature Seals : Viton
■ Spring : Stainless	
■ Cap : Zinc Pressure Die-Cast	

\* The specification on each item can be amended without any prenotice to improve a performance.  
\* The specification on each item can be different from actual specification.

## ORDERING NO.

**SIE2 1 1 - I P - SC1 - CN1 - A2**

Valve Series	Function	Return Method	Int/Ext. Pilot	Manual Operator	Solenoid Coil Type	Connector Type	Voltage
SIE2 : Solenoid Valve	1	5/2 Single	0 None	I Internal Pilot	0 None	0 None	0 None
	2	5/2 Double	1 Air + Spring	E External Pilot	P Push Non-Locking	CN1 Normal Connector	A2 AC 220V
	3	5/3 Closed Center	2 Air		L Lever Locking	SG1 Grommet/Flying Leads	A1 AC 110V
SIEP2 : Pneumatic Valve	4	5/3 Open Center	3 Spring		SD1 Grommet/Flying Leads With LED	CZ1 Connector With LED & Surge Suppressor	A4 AC 24V
	5	5/3 Pressure Center			SL1 90 Degree Plug-in Wire Assembly With LED		D4 DC 24V
					SM1 180 Degree Plug-in Wire Assembly With LED		D2 DC 12V

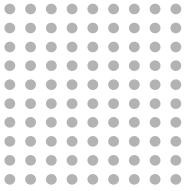

# Solenoid & Pilot Actuated Spool Valves

## 18mm Body Width

### 5Port 2Position Solenoid Valve

Single Solenoid  
SIE211-IP-SG1-\*\*\*

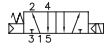

External Pilot  
SIE211-EP-SG1-\*\*\*

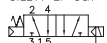

SIE211-IP-SM1-\*\*\*

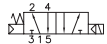

SIE211-IP-SC1-CN1-\*\*\*

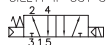

Double Solenoid  
SIE220-IP-SL1-\*\*\*

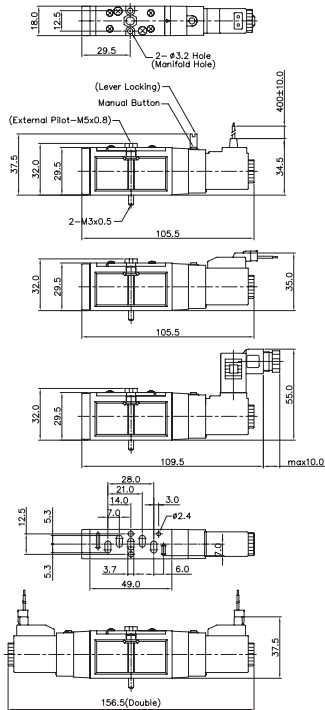
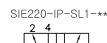

### 5Port 2Position Pneumatic Valve

Single Pneumatic  
SIEP211

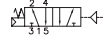

Double Pneumatic  
SIEP220

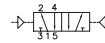

### 5Port 3Position Pneumatic Valve

Closed Center  
SIEP233

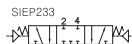

Exhaust Center  
SIEP243



Pressure Center  
SIEP253

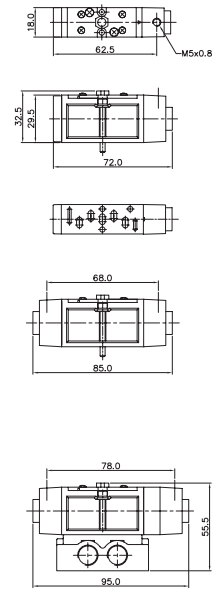
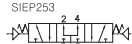

### 5Port 3Position Solenoid Valve

Closed Center  
SIE233-IP-SC1-CN1-\*\*\*

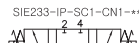

Exhaust Center  
SIE243-IP-SC1-CN1-\*\*\*

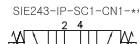

Pressure Center  
SIE253-IP-SC1-CN1-\*\*\*

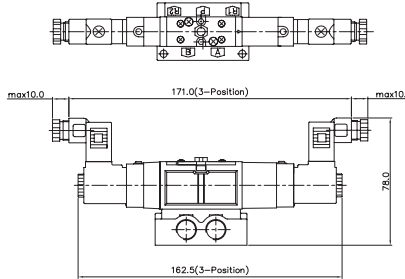
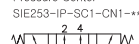

### Sub Base Ordering Code

Sub Base Series	Port & Threaded	Function
SIB2	0 None	S Single Station Sub Base, 1/4 Port Without Pilot Ports
SIE200 Solenoid Valve	1 G	SP Single Station Sub Base, 1/4 Port With Pilot Ports
	2 NPT	DB Double Modular Sub Base, 1/8 Port Without Pilot Ports
		DC6 Double Modular Sub Base #6 One-Touch Fitting
		E End Cover, 1/8 Port
		EB End Blanking Cover

## SIB20 SINGLE, DOUBLE SUB BASE

(SIE200 Solenoid & Pneumatic Valve Use Sub Base)

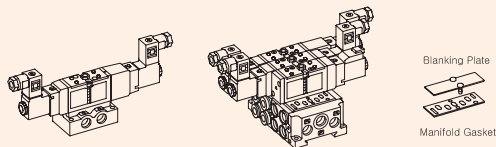

### Single Station Sub Base Dimension

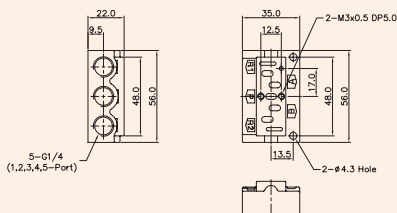

### Double Modular Sub Base Dimension

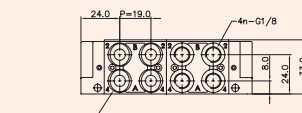
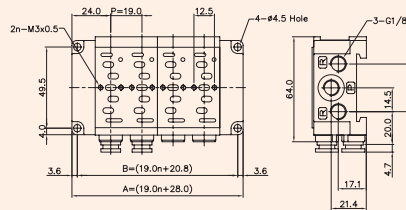

DOUBLE MODULAR SUB BASE DIMENSION (n=STATION)	2	4	6	8	10
B	58.8	96.8	134.8	172.8	210.8
A	66.0	104.0	142.0	180.0	218.0

Ordering Code SIB20-BLK	Blanking Plate (Material: STS304)
	Manifold Gasket. (Material: NBR)
Ordering Code SIB21-E	End Cover, 1/8 (Material: Al)
Ordering Code SIB20-EB	End Blanking Cover (Material: Al)
Ordering Code SIB21-DB	Double Modular Sub Base, 1/8 (Material: Al)
Ordering Code SIB20-DC6	Double Modular Sub Base ø6 one-touch fitting (Material: Al)

# SIE300

"E" ECONOMY Series  
Solenoid / Pneumatic Valves

- 5/2, 5/3
- 26mm Body Width
- Sub-Base or Manifold Mounting Type
- Transition Flow 1000ℓ/min (5bar)

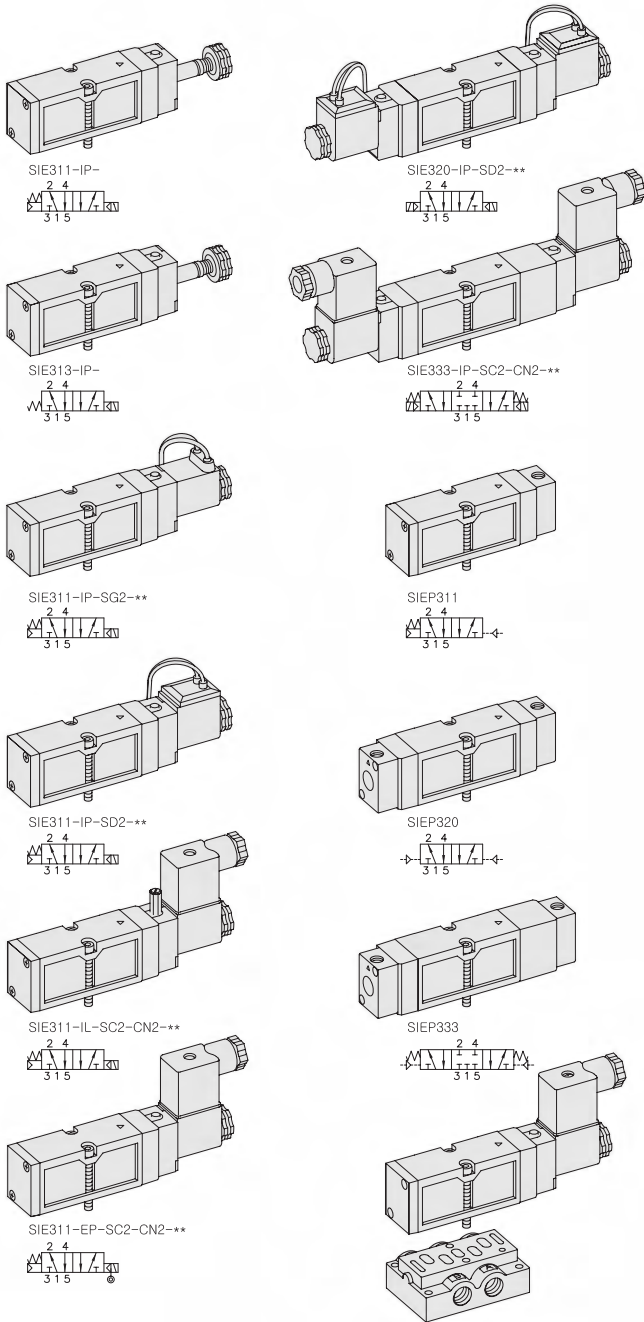

\*\* : Voltage Selection (see page 80)

## SPECIFICATION

ITEM	SERIES FUNCTION	SOLENOID, PNEUMATIC	
		5 Port 2 Position	5 Port 3 Position
Fluids		Compressed Air & Inert Gases	
Pressure(bar)		1.5~10.0	2.0~10.0
Eff. Sectional Area(mm <sup>2</sup> )-5bar		18.0	11.0
Ambient & Fluid Temp.		5~60°C (41~140°F)	
Response Time(5bar)		25ms or Less	35ms or Less
Max. Working Frequency		5c/sec	3c/sec
Lubrication		Not Required(Use ISO VG32 #)	
Manual Override		Push Button(Standard), Lever Lock(Optional)	
Coil Insulation Class		F-Class or Equivalent	
Permissible Voltage Variation		±10% of Rated Voltage	
Off Min. Residual Voltage		AC:20% or Less / DC:10% or Less	
Power Consumption		Holding-AC:5.5VA(60Hz) / DC:2.5W	

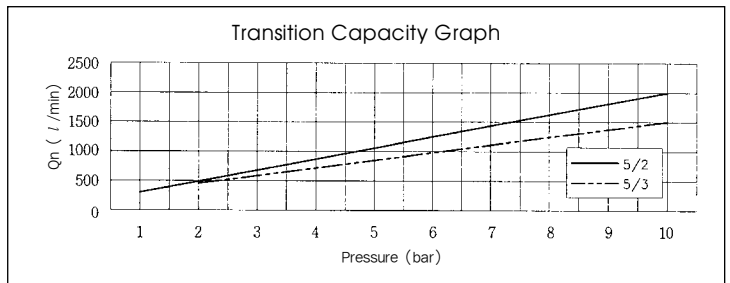

- ### The Material of Parts
- Valve Body : Die-Cast Aluminium
  - Spool : Aluminium
  - Seals : NBR
  - Spring : Stainless
  - Cap : Zinc Pressure Die-Cast
  - Pilot Parts : Glass Filled Nylon
  - Armature : Stainless Steel
  - Armature Seals : Viton

\* The specification on each item can be amended without any prenotice to improve a performance.  
\* The specification on each item can be different from actual specification.

## ORDERING NO.

**SIE3 1 1 - I P - SC2 - CN2 - A2**

Valve Series	Function	Return Method	Int/Ext. Pilot	Manual Operator	Solenoid Coil Type	Connector Type	Voltage
SIE3 : Solenoid Valve	1	5/2 Single	0 None	I Internal Pilot	0 None	0 None	0 None
	2	5/2 Double	1 Air+Spring	E External Pilot	SC2 3 Pin Connector Coil	CN2 Normal Connector	A2 AC 220V
	3	5/3 Closed Center	2 Air		L Lever Locking	SG2 Grommet/Flying Leads	A1 AC 110V
	4	5/3 Open Center	3 Spring			SD2 Grommet/Flying Leads With LED	A4 AC 24V
	5	5/3 Pressure Center					D4 DC 24V
SIEP3 : Pneumatic Valve						C22 Connector With LED & Surge Suppressor	D2 DC 12V



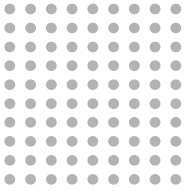

# Solenoid & Pilot Actuated Spool Valves

## 26mm Body Width

### 5Port 2Position Solenoid Valve

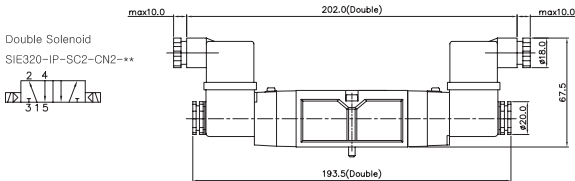
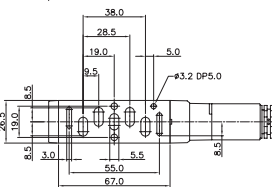
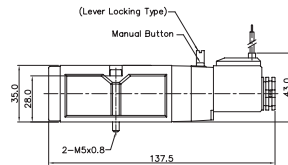
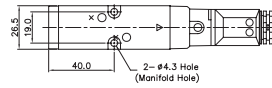
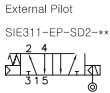
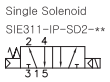

### 5Port 2Position Pneumatic Valve

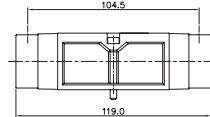
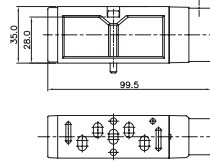
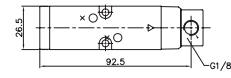
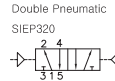
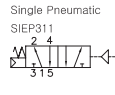

### 5Port 3Position Pneumatic Valve

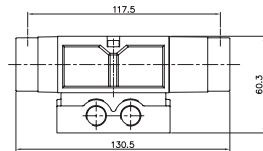
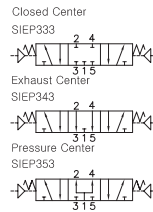

### 5Port 3Position Solenoid Valve

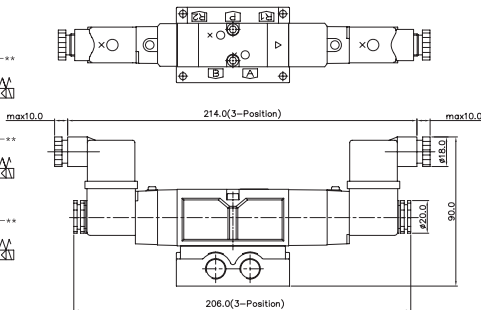
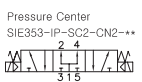
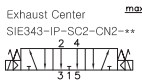
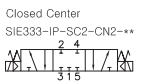

### Sub Base Ordering Code

SIB3		1 - S	
Sub Base Series	Port & Thread	Function	
SIB3	0 None	S	Single Station Sub Base, 1/4 Port Without Pilot Ports
SIE300 Solenoid Valve	1 G	SP	Single Station Sub Base, 1/4 Port With Pilot Ports
	2 NPT	DB	Double Modular Sub Base, 1/4 Port Without Pilot Ports
		DC8	Double Modular Sub Base, Ø8 One-Touch Fitting
		E	End Cover, 1/4 Port
		EB	End Blanking Cover

## SIB30 SINGLE, DOUBLE SUB BASE

(SIE300 Solenoid & Pneumatic Valve Use Sub Base)

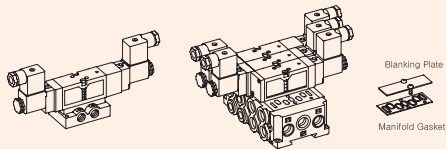

### Single Station Sub Base Dimension

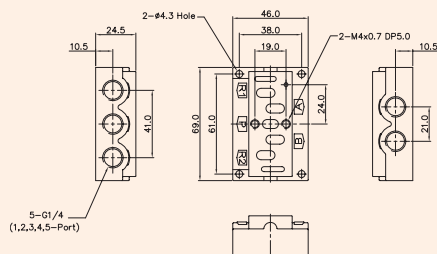

### Double Modular Sub Base Dimension

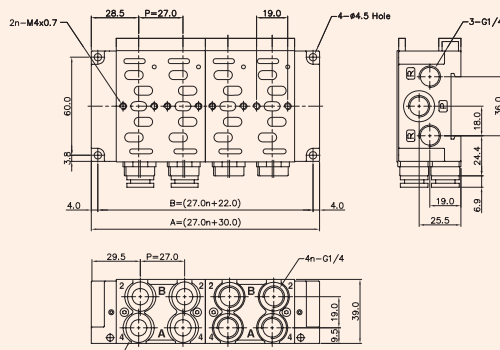

DOUBLE MODULAR SUB BASE DIMENSION		n-STATION				
ITEM	n	2	4	6	8	10
A		76.0	130.0	184.0	238.0	292.0
B		84.0	138.0	192.0	246.0	300.0

Ordering Code SIB30-BLK	Blanking Plate (Material: STS304)
	Manifold Gasket. (Material: NBR)
Ordering Code SIB31-E	End Cover, 1/4 (Material: AI)
Ordering Code SIB30-EB	End Blanking Cover (Material: AI)
Ordering Code SIB31-DB	Double Modular Sub Base, 1/4 (Material: AI)
Ordering Code SIB30-DC8	Double Modular Sub Base Ø8 one-touch fitting (Material: AI)





# MCS Series

Multi Connector System (SC Series Solenoid Valve Mounted)

## CHAPTER 05



MCS100  
SC200  
Solenoid Valve  
MOUNTED



MCS100  
SC300, SCE300  
Solenoid Valve  
MOUNTED



MCS100  
SC400, SCE400  
Solenoid Valve  
MOUNTED

### ■ MCS100

# MCS100

Multi Connector System

SC200, 300, 400 Series Solenoid Valve MOUNTED

- DC 24V/ DC 12V
- 25Pin D-Sub Connector
- Simple Electric Wire System

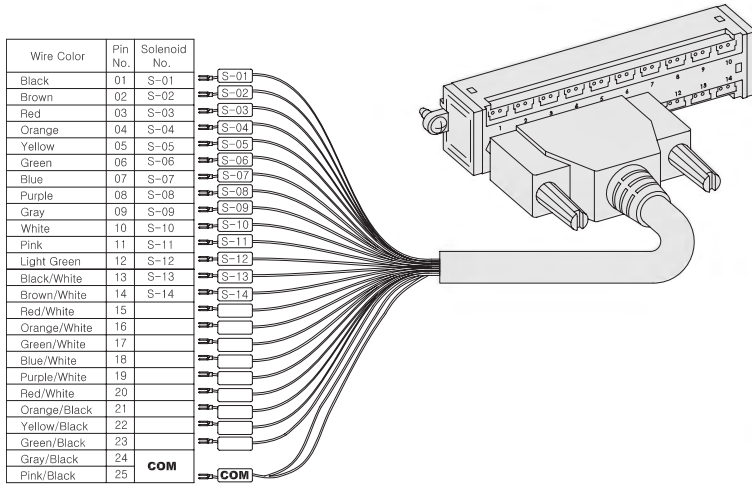

D-Sub Connector Pin No.

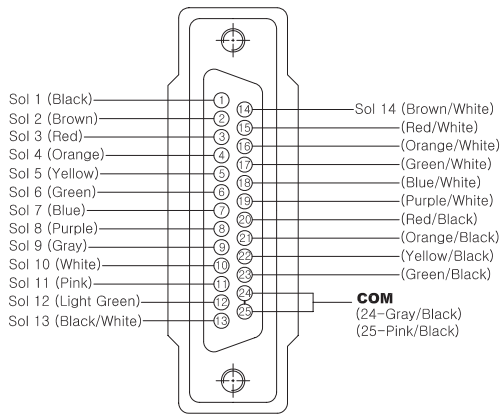

Terminal Box  
MCS100 -T14-D4

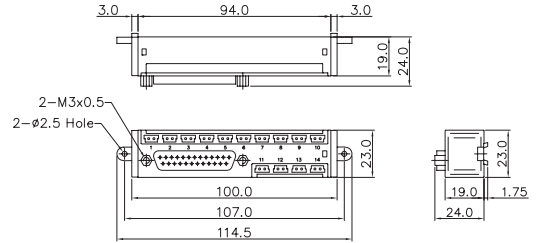

- SC311D-F5-P-L-\*\*
- SC321D-F5-P-L-\*\*
- SC333D-F5-P-\*\*\*

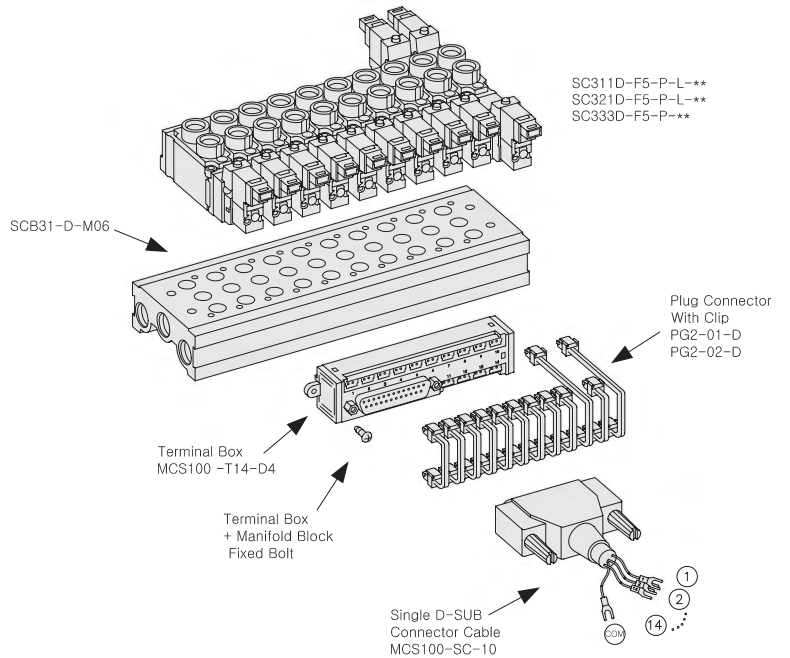

<p><b>Terminal Box</b></p> <p>Ordering Code MCS100 -T14-**</p>	<p><b>Plug Connector With Clip</b></p> <p>Ordering Code PG2-01-D (100mm) PG2-02-D (200mm)</p>	<p><b>Single D-Sub Connector Cable IP40</b></p> <p>Ordering Code MCS100-SC-10 (1m) MCS100-SC-30 (3m)</p>
--	---	--

## ORDERING NO.

**MCS1 0 0 - T14 - D4**

Series	Function	D-Sub Connector	Multipole Wireway Box	Voltage
MCS1 : Multi Connector Solenoid Valve Mounted	0   Single Module	0   25 Pin D-Sub Connector	T14   14 Station	0   None D4   DC 24V D2   DC 12V

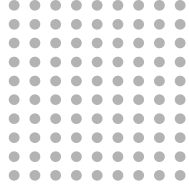

# Multi Connector System

# Solenoid Valve Mounted

## SC200 Series Mounted

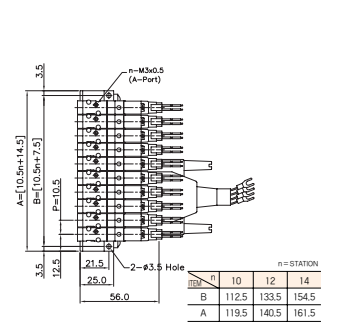
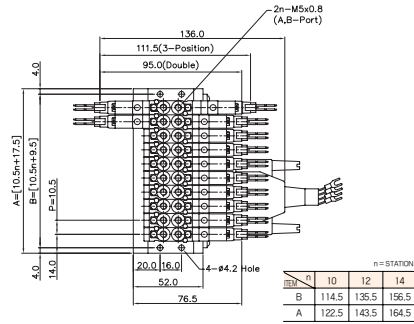
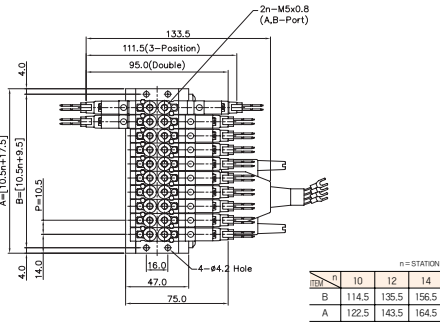

## SC300 Series Mounted

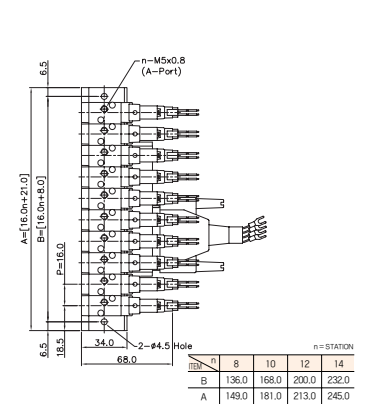
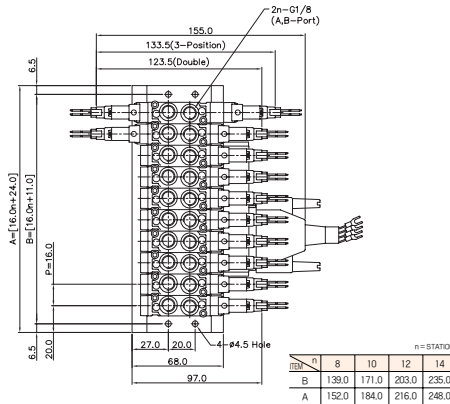
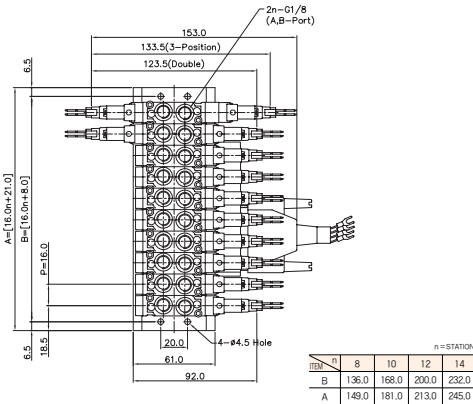

## SC400 Series Mounted

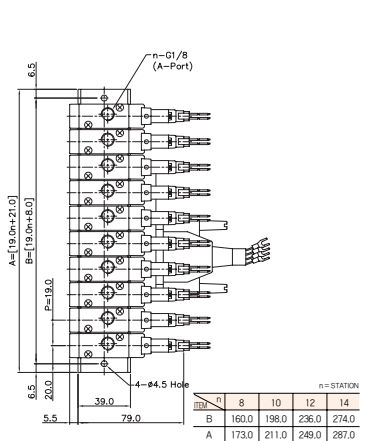
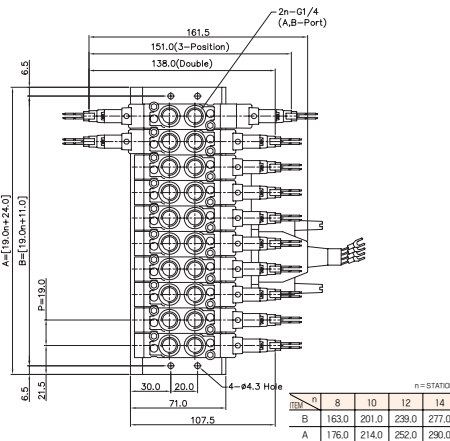
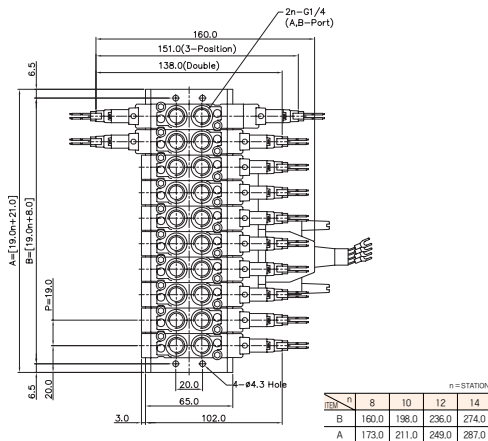

# MCS100

Multi Connector System

SCE 300, 400 Series Solenoid Valve MOUNTED

- DC 24V/ DC 12V
- 25Pin D-Sub Connector
- Simple Electric Wire System

Wire Color	Pin No.	Solenoid No.
Black	01	S-01
Brown	02	S-02
Red	03	S-03
Orange	04	S-04
Yellow	05	S-05
Green	06	S-06
Blue	07	S-07
Purple	08	S-08
Gray	09	S-09
White	10	S-10
Pink	11	S-11
Light Green	12	S-12
Black/White	13	S-13
Brown/White	14	S-14
Red/White	15	
Orange/White	16	
Green/White	17	
Blue/White	18	
Purple/White	19	
Red/White	20	
Orange/Black	21	
Yellow/Black	22	
Green/Black	23	
Gray/Black	24	COM
Pink/Black	25	COM

### D-Sub Connector Pin No.

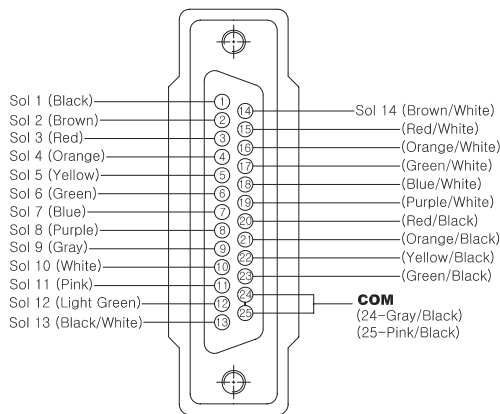

### Terminal Box MCS100 -T14-D4

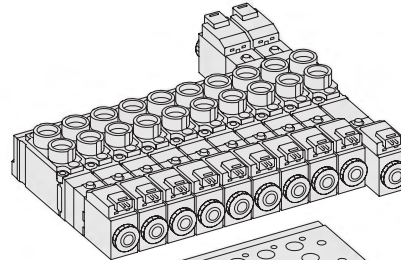
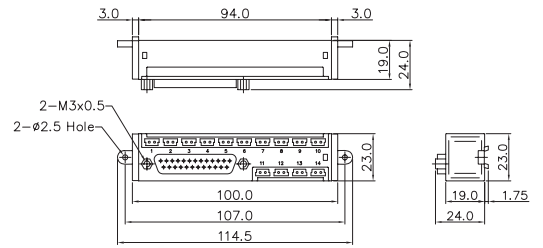

- SCE311D-F5-P-L-\*\*
- SCE321D-F5-P-L-\*\*
- SCE333D-F5-P-\*\*\*

SCB31-D-M06

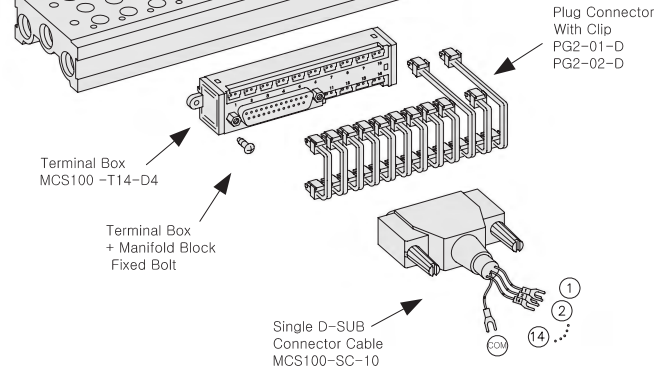

Terminal Box	Plug Connector With Clip	Single D-Sub Connector Cable IP40
Ordering Code MCS100 -T14-**	Ordering Code PG2-01-D (100mm) PG2-02-D (200mm)	Ordering Code MCS100-SC-10 (1m) MCS100-SC-30 (3m)

### ORDERING NO.

**MCS1 0 0 - T14 - D4**

Series	Function	D-Sub Connector	Multipole Wireway Box	Voltage
MCS1 : Multi Connector Solenoid Valve Mounted	0   Single Module	0   25 Pin D-Sub Connector	T14   14 Station	0   None D4   DC 24V D2   DC 12V

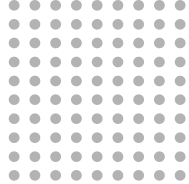

# Multi Connector System

# Solenoid Valve Mounted

## SCE300 Series Mounted

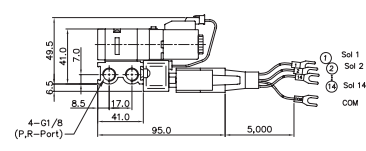
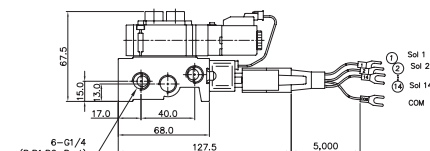
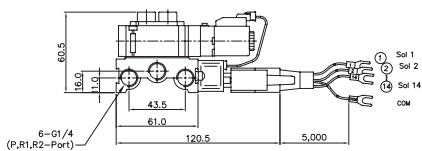
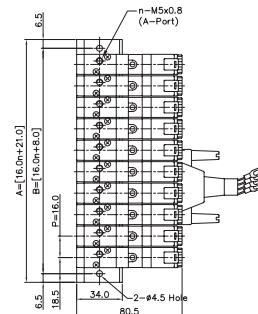
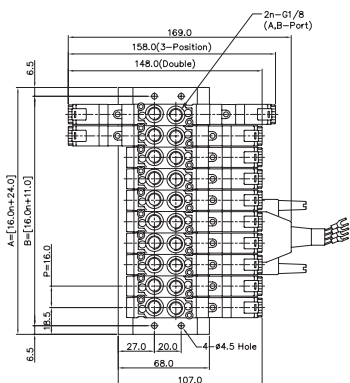
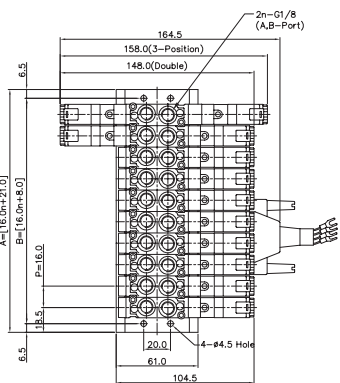

n=STATION					
ITEM	n	8	10	12	14
B		136.0	168.0	200.0	232.0
A		149.0	181.0	213.0	245.0

n=STATION					
ITEM	n	8	10	12	14
B		139.0	171.0	203.0	235.0
A		152.0	184.0	216.0	248.0

n=STATION					
ITEM	n	8	10	12	14
B		136.0	168.0	200.0	232.0
A		149.0	181.0	213.0	245.0

## SCE400 Series Mounted

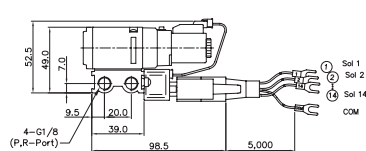
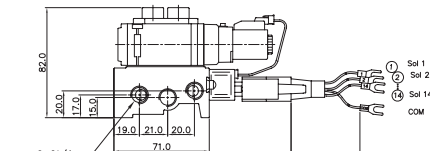
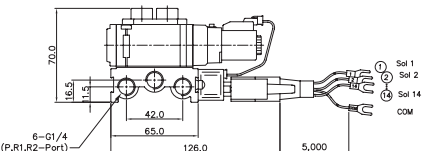
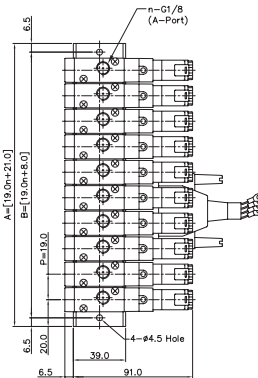
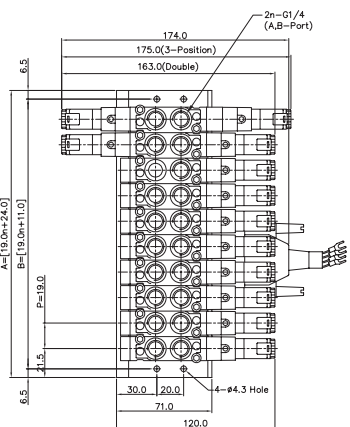
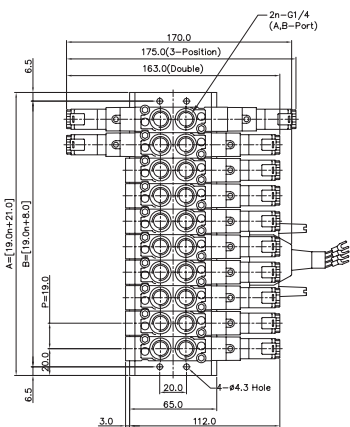

n=STATION					
ITEM	n	8	10	12	14
B		160.0	198.0	236.0	274.0
A		173.0	211.0	249.0	287.0

n=STATION					
ITEM	n	8	10	12	14
B		163.0	201.0	239.0	277.0
A		176.0	214.0	252.0	290.0

n=STATION					
ITEM	n	8	10	12	14
B		160.0	198.0	236.0	274.0
A		173.0	211.0	249.0	287.0





# SC·SCE (COMPACT) Series

## 5/2, 5/3, 3/2 Solenoid, Pneumatic Valve

### CHAPTER 06



SC200  
Body Width-10mm  
Thread-M5, M3



SC300  
Body Width-15mm  
Thread-1/8, M5



SC400  
Body Width-18mm  
Thread-1/4, 1/8

- SC200
- SC300
- SC400



SCE300  
Body Width-15mm  
Thread-1/8, M5



SCE400  
Body Width-18mm  
Thread-1/4, 1/8



SCE500  
Body Width-26mm  
Thread-3/8

- SCE300
- SCE400
- SCE500

# SC200. M5

"C" COMPACT Series  
Solenoid / Pneumatic Valves

- 5/2, 5/3-M5, 3/2-M3 ■ 10mm Body Width
- Manifold or Sub-Base Type
- High Efficiency, Space Economy Type
- Transition Flow 130ℓ/min (5bar)

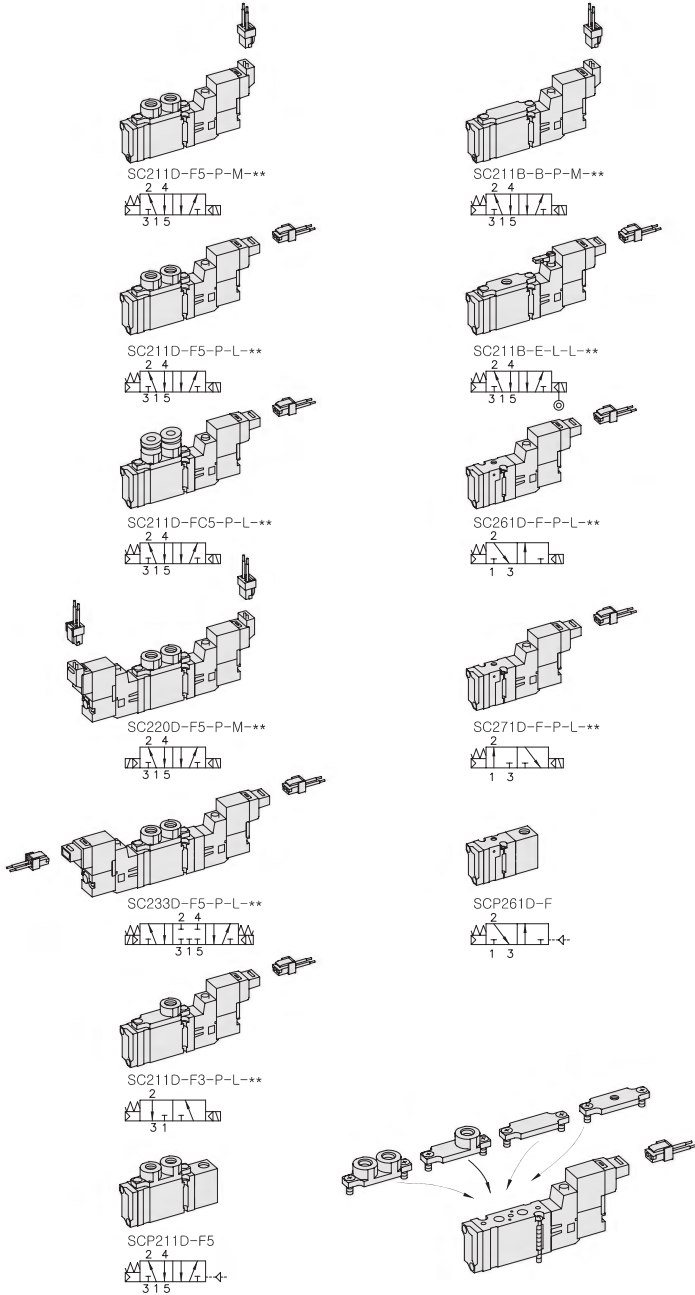

\*\* : Voltage Selection (see page 10)

## SPECIFICATION

ITEM	SERIES	SOLENOID, PNEUMATIC	
		5, 3Port 2Position	5Port 3Position
Fluids		Compressed Air & Inert Gases	
Pressure(bar)		2.0~7.0	2.5~7.0
Eff. Sectional Area(mm <sup>2</sup> )-5bar		2.3	1.8
Ambient & Fluid Temp.		5~60°C (41~140°F)	
Response Time(5bar)		20ms or Less	30ms or Less
Max. Working Frequency		10c/sec	8c/sec
Lubrication		Not Required(Use ISO VG32 #)	
Manual Override		Push Button(Standard), Lever Lock(Option)	
Coil Insulation Class		F-Class or Equivalent	
Permissible Voltage Variation		±10% of Rated Voltage	
Off Min. Residual Voltage		DC:10% or Less	
Power Consumption(DC)		Holding-DC: 0.65W (24V:27.0mA/12V:54.0mA)	

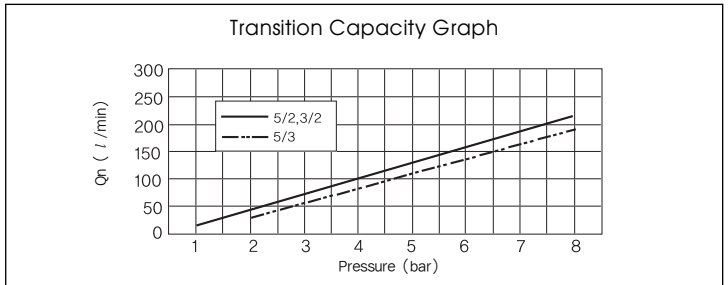

### The Material of Parts

- Valve Body : Die-Cast Aluminium
- Spool : Aluminium
- Seals : NBR
- Spring : Stainless
- Cap : Zinc Pressure Die-Cast
- Pilot Parts : Glass Filled Nylon
- Armature : Stainless Steel
- Armature Seals : Viton

### Port Plate Ordering Code (Material : Zinc)

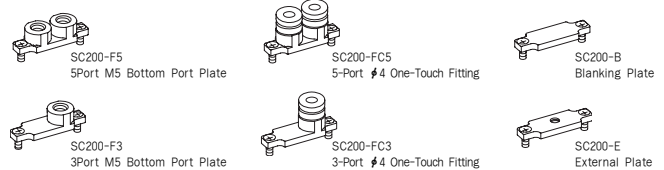

\* The specification on each item can be amended without any prenotice to improve a performance.  
\* The specification on each item can be different from actual specification.

## ORDERING NO.

**SC2 1 1 D - F5 - P - L - D4**

Valve Series	Function	Return Method	Port Type	Port Plate & Thread	Manual Operator	Solenoid Coil Type	Voltage
SC2 : Solenoid Valve	1 5/2 Single	0 None	D Manifold	0 None	0 None	0 None	0 None
	2 5/2 Double	1 Air + Spring	B Sub-Base	F5 5-Port M5×0.8	P Push Non-Locking	L 90 Degree Plug-in Wire Assembly with LED	D4 DC 24V
	3 5/3 Closed Center	2 Air		F3 3-Port M5×0.8	L Lever Locking	M 180 Degree Plug-in Wire Assembly with LED	D2 DC 12V
SCP2 : Pneumatic Valve	4 5/3 Open Center	3 Spring		FN5 5-Port NPT M5×0.8			
	5 5/3 Pressure Center			FN3 3-Port NPT M5×0.8			
	6 3/2 Normally Closed			FC5 5-Port φ4 One-Touch Fitting			
	7 3/2 Normally Open			FC3 3-Port φ4 One-Touch Fitting			
				E External End Plate, Plate M3×0.5			
				B Blanking End Plate			

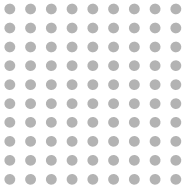

# Solenoid & Pilot Actuated Spool Valves

# Port Thread M5, M3

## 5Port 2Position Solenoid Valve (Manifold)

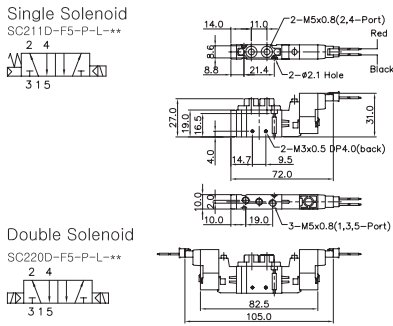

## 5Port 2Position Solenoid Valve (Sub-Base)

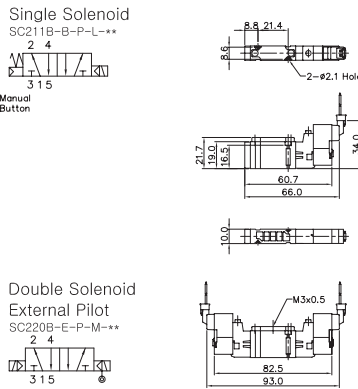

## 5Port 2Position Pneumatic Valve

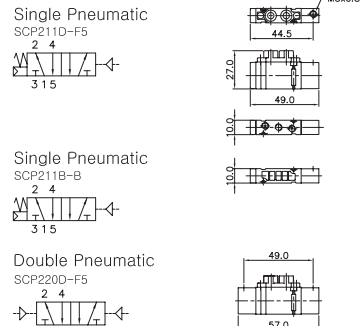

## 5Port 3Position Solenoid Valve (Manifold)

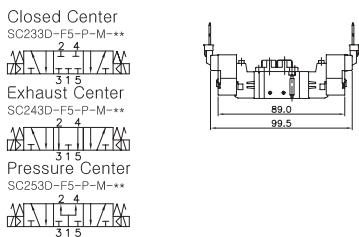

## 5Port 3Position Solenoid Valve (Sub-Base)

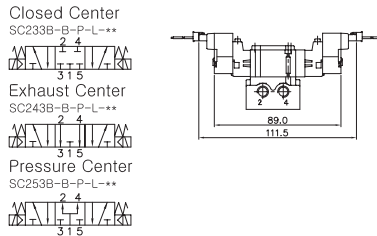

## 5Port 3Position Pneumatic Valve

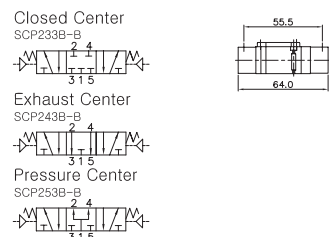

## 3Port 2Position Solenoid Valve (Manifold)

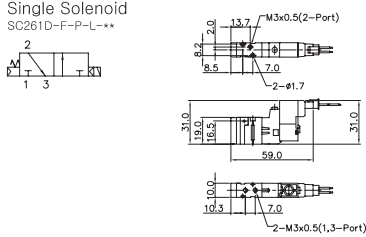

## 3Port 2Position Pneumatic Valve

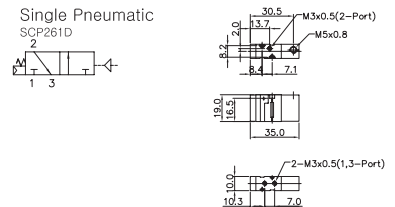

# SCB20 SINGLE, DOUBLE MANIFOLD BLOCK

(SC200 Solenoid & Pneumatic Valve Use)

## Manifold Block Dimension

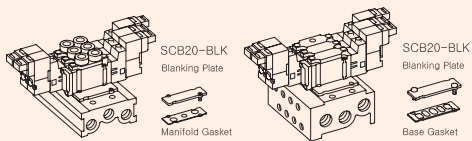

## Double Modular Manifold Block Dimension

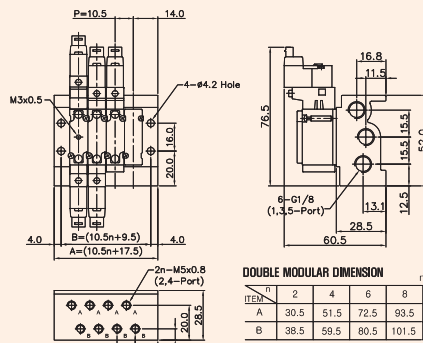

## Manifold Ordering Code

SCB2 1 - D - M04

Series	Port & Thread	Function	Manifold Station
SCB2	0 None	0 None	M02 2-Station
SC200 Solenoid Valve	1 G	S Single Station Sub Base, 1/8 Port Without Pilot Ports	M04 4-Station
	2 NPT	D Manifold, Port 1/8	M06 6-Station
		DB Double Modular Manifold Block, M5 Port	M08 8-Station
		DC4 Double Modular Manifold Block, Ø 4 Fitting	M10 10-Station
		D3 Manifold, M5 Port Without Pilot Ports(3/2Way)	

## Single Station Sub Base Dimension (SCB21-S)

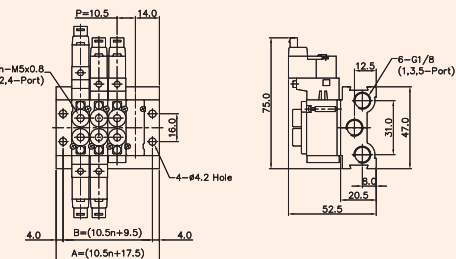
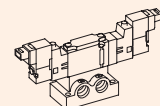

DOUBLE MODULAR DIMENSION

ITEM	n	2	4	6	8	10
A	30.5	51.5	72.5	93.5	114.5	
B	38.5	59.5	80.5	101.5	122.5	

## 5PORT MANIFOLD BLOCK DIMENSION

ITEM	n	2	4	6	8	10
A	30.5	51.5	72.5	93.5	114.5	
B	38.5	59.5	80.5	101.5	122.5	

## 3PORT MANIFOLD BLOCK DIMENSION

ITEM	n	2	4	6	8	10
A	28.5	49.5	70.5	91.5	112.5	
B	35.5	56.5	77.5	98.5	119.5	

## Manifold Block Dimension

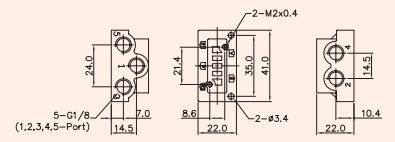
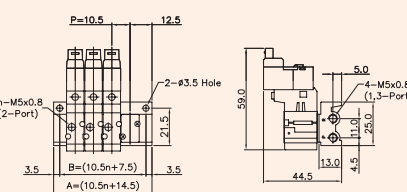

Ordering Code	Ordering Code
SCB26-BLK	SCB20-BLK
Blanking Plate Material: STS304	Blanking Plate (Material: STS304)
Manifold Gasket. (Material: NBR)	Manifold Gasket. Base Gasket. (Material: NBR)



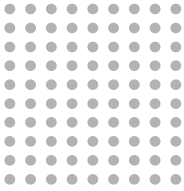

# Solenoid & Pilot Actuated Spool Valves

# Port Thread 1/8, M5

## 5Port 2Position Solenoid Valve (Manifold)

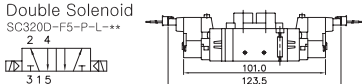
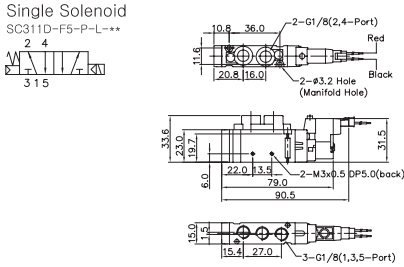

## 5Port 3Position Solenoid Valve (Manifold)

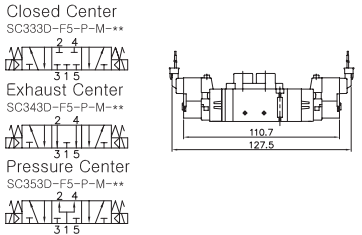

## 3Port 2Position Solenoid Valve (Manifold)

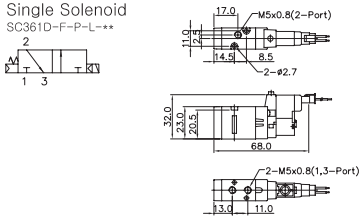

## 5Port 2Position Solenoid Valve (Sub-Base)

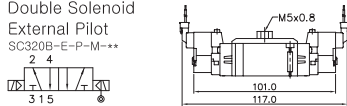
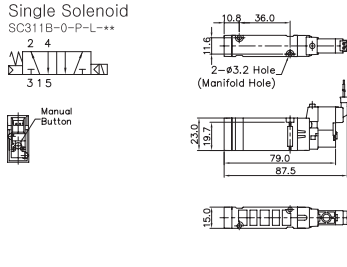

## 5Port 3Position Solenoid Valve (Sub-Base)

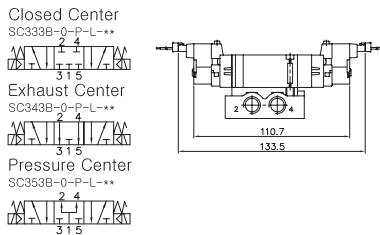

## 5Port 2Position Pneumatic Valve

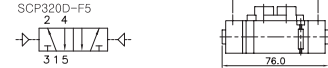
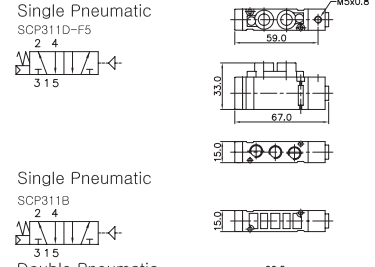

## 5Port 3Position Pneumatic Valve

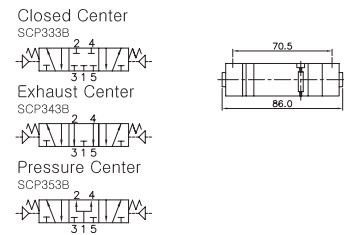

## 3Port 2Position Pneumatic Valve

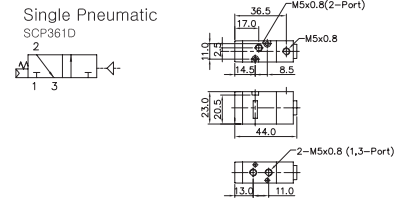

# SCB30 SINGLE, DOUBLE MANIFOLD BLOCK

(SC300 Solenoid & Pneumatic Valve Use)

## Manifold Block Dimension

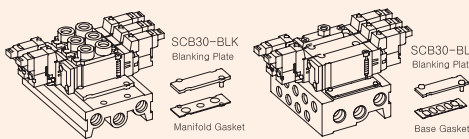

## Double Modular Manifold Block Dimension

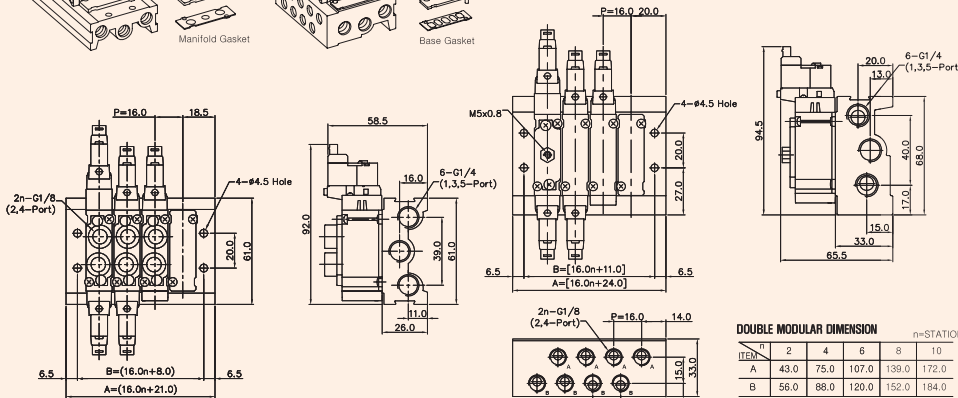

5PORT MANIFOLD BLOCK DIMENSION n=STATION

ITEM	n	2	4	6	8	10
A		40.0	72.0	104.0	136.0	168.0
B		53.0	85.0	117.0	149.0	181.0

3PORT MANIFOLD BLOCK DIMENSION n=STATION

ITEM	n	2	4	6	8	10
A		40.0	72.0	104.0	136.0	168.0
B		53.0	85.0	117.0	149.0	181.0

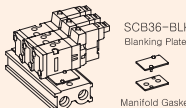

## Manifold Block Dimension

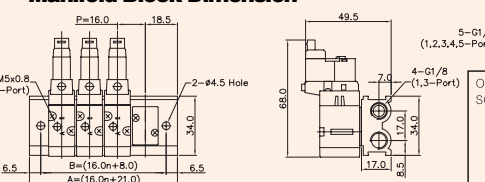

Ordering Code  
SCB36-BLK

- Blanking Plate (Material: STS304)
- Manifold Gasket (Material: NBR)

Ordering Code  
SCB30-BLK

- Blanking Plate (Material: STS304)
- Manifold Gasket (Material: NBR)
- Base Gasket (Material: NBR)

## Manifold Ordering Code

SCB3 1 - D - M04

Series	Port & Thread	Function	Manifold Station
SCB3	0	None	M02
SC300 Solenoid Valve	1	G	M04
	2	NPT	M06
		None	M08
		Single Station Sub Base, 1/4 Port Without Pilot Ports	M10
		1/4 Port	
		Double Modular Manifold Block, 1/8 Port	
		Double Modular Manifold Block, ø6 Fitting	
		Manifold, Port 1/8(3/2Way)	

## Single Station Sub Base Dimension (SCB31-S)

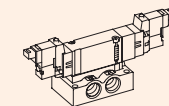

# SC400. 1/4

"C" COMPACT Series  
Solenoid / Pneumatic Valves

- 5/2, 5/3-1/4, 3/2-1/8 ■ 18mm Body Width
- Manifold or Sub-Base Type
- High Efficiency, Space Economy Type
- Transition Flow 900ℓ/min (5bar)

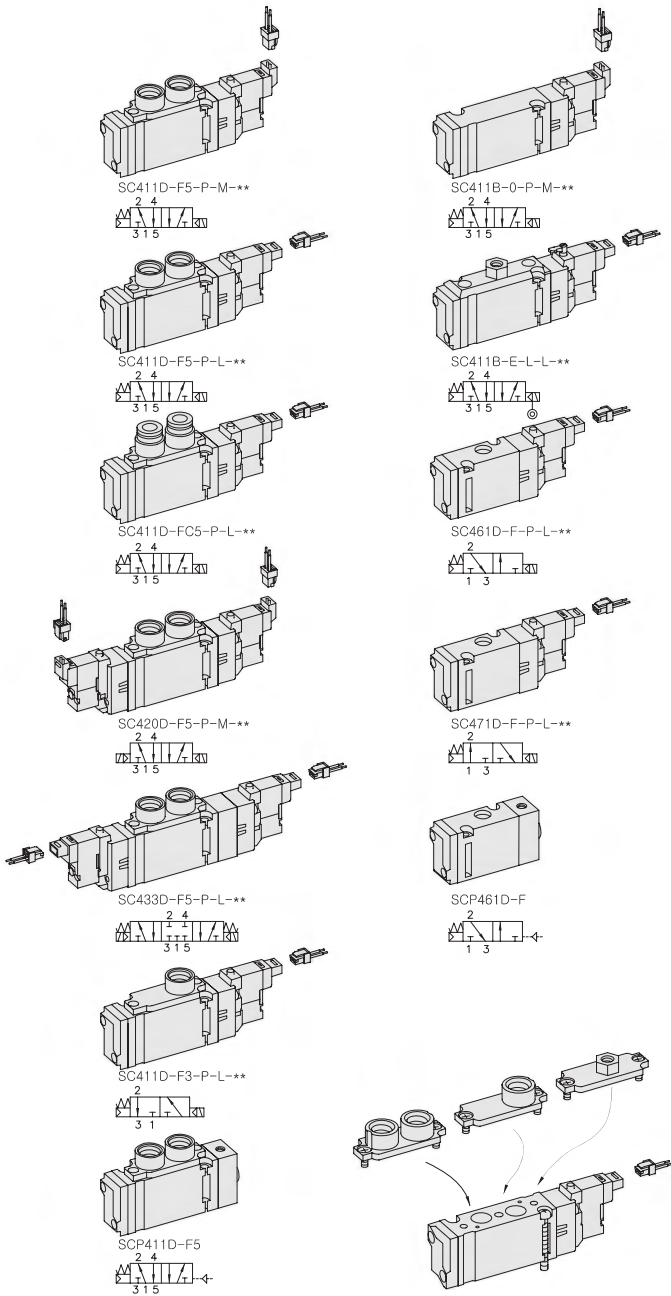

\*\* : Voltage Selection (see page 10)

## SPECIFICATION

ITEM	SERIES	SOLENOID, PNEUMATIC	
		FUNCTION	
		5, 3Port 2Position	5Port 3Position
Fluids		Compressed Air & Inert Gases	
Pressure(bar)		1.5~7.0	2.0~7.0
Eff. Sectional Area(mm <sup>2</sup> )-5bar		16.0	12.0
Ambient & Fluid Temp.		5~60°C (41~140°F)	
Response Time(5bar)		25ms or Less	35ms or Less
Max. Working Frequency		5c/sec	3c/sec
Lubrication		Not Required(Use ISO VG32 #)	
Manual Override		Push Button(Standard), Lever Lock(Option)	
Coil Insulation Class		F-Class or Equivalent	
Permissible Voltage Variation		±10% of Rated Voltage	
Off Min. Residual Voltage		DC:10% or Less	
Power Consumption(DC)		Holding-DC: 0.65W (24V:27.0mA/12V:54.0mA)	

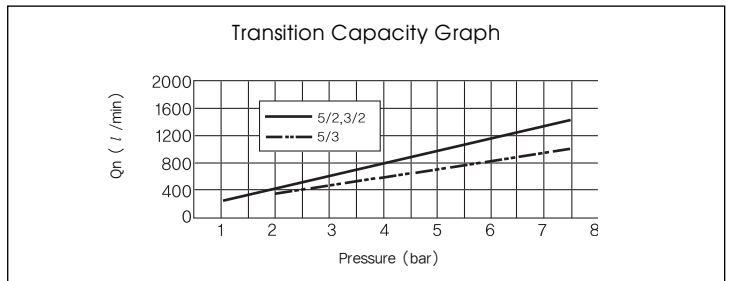

- ### The Material of Parts
- Valve Body : Die-Cast Aluminium
  - Cap : Zinc Pressure Die-Cast
  - Spool : Aluminium
  - Pilot Parts : Glass Filled Nylon
  - Seals : NBR
  - Armature : Stainless Steel
  - Spring : Stainless
  - Armature Seals : Viton

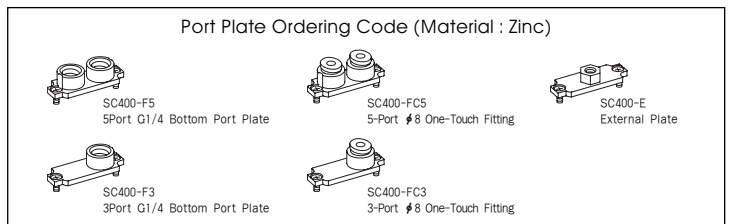

\* The specification on each item can be amended without any prenotice to improve a performance.  
\* The specification on each item can be different from actual specification.

## ORDERING NO.

**SC4 1 1 D - F5 - P - L - D4**

Valve Series	Function	Return Method	Port Type	Port Plate & Thread	Manual Operator	Solenoid Coil Type	Voltage
SC3 : Solenoid Valve	1 5/2 Single	0 None	D Manifold	0 None	0 None	0 None	0 None
	2 5/2 Double	1 Air + Spring	B Sub-Base	F5 5-Port G1/4	P Push	L 90 Degree Plug-in Wire Assembly with LED	D4 DC 24V
	3 5/3 Closed Center	2 Air		F3 3-Port G1/4	Non-Locking		D2 DC 12V
SCP3 : Pneumatic Valve	4 5/3 Open Center	3 Spring		FN5 5-Port NPT1/4	L Lever Locking	M 180 Degree Plug-in Wire Assembly with LED	
	5 5/3 Pressure Center			FN3 3-Port NPT1/4			
	6 3/2 Normally Closed			FC5 5-Port ø8 One-Touch Fitting			
	7 3/2 Normally Open			FC3 3-Port ø8 One-Touch Fitting			
				E External End Plate, Plate M5×0.8			



# Solenoid & Pilot Actuated Spool Valves

## Port Thread 1/4, 1/8

### 5Port 2Position Solenoid Valve (Manifold)

Single Solenoid  
SC411D-F5-P-L-\*\*\*

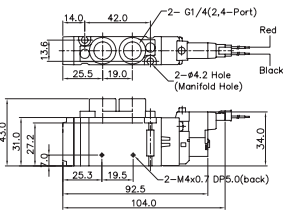
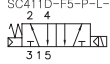

Double Solenoid  
SC420D-F5-P-L-\*\*\*

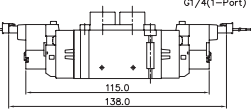
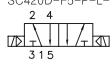

### 5Port 3Position Solenoid Valve (Manifold)

Closed Center  
SC433D-F-P-M-\*\*\*

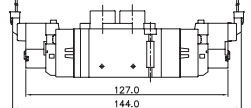
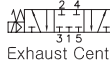

Exhaust Center  
SC443D-F5-P-M-\*\*\*

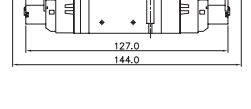

Pressure Center  
SC453D-F5-P-M-\*\*\*



### 3Port 2Position Solenoid Valve (Manifold)

Single Solenoid  
SC461D-F-P-L-\*\*\*

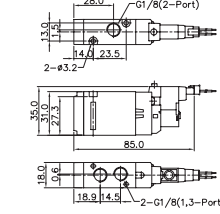
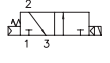

### 5Port 2Position Solenoid Valve (Sub-Base)

Single Solenoid  
SC411B-0-P-L-\*\*\*

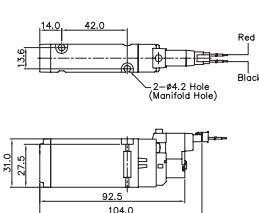
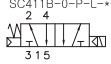

Double Solenoid  
External Pilot  
SC420B-E-P-L-\*\*\*

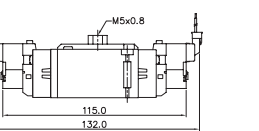
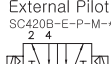

### 5Port 3Position Solenoid Valve (Sub-Base)

Closed Center  
SC433B-0-P-L-\*\*\*

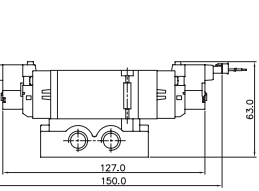
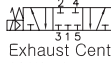

Exhaust Center  
SC443B-0-P-L-\*\*\*

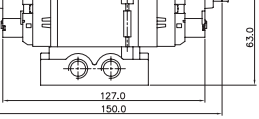

Pressure Center  
SC453B-0-P-L-\*\*\*

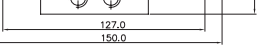
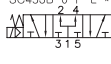

### 5Port 2Position Pneumatic Valve

Single Pneumatic  
SCP411D-F5

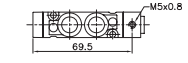
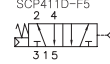

Single Pneumatic  
SCP411B

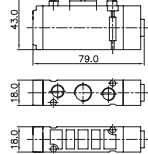

Double Pneumatic  
SCP420D-F5

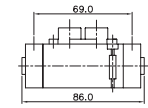

### 5Port 3Position Pneumatic Valve

Closed Center  
SCP433B

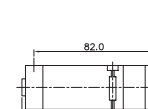
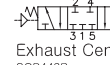

Exhaust Center  
SCP443B

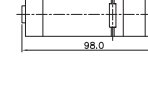
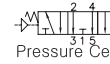

Pressure Center  
SCP453B

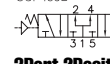

### 3Port 2Position Pneumatic Valve

Single Pneumatic  
SCP461D

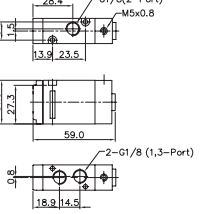
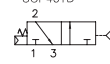

## SCB40 SINGLE, DOUBLE MANIFOLD BLOCK

(SC400 Solenoid & Pneumatic Valve Use)

### Manifold Block Dimension

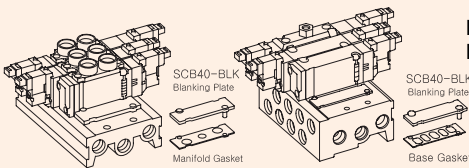

### Double Modular Manifold Block Dimension

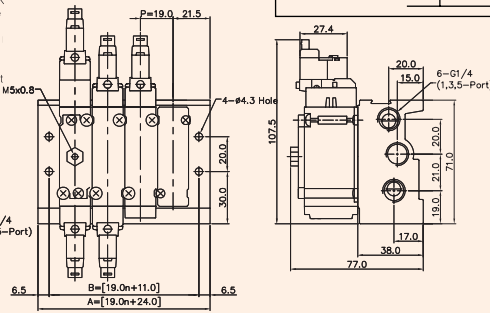

Double Modular Sub Base Dimension

ITEM	2	4	6	8	10
B	49.0	87.0	125.0	163.0	201.0
A	62.0	100.0	138.0	176.0	214.0

### Manifold Block Dimension

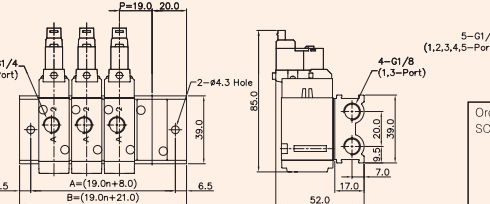

5Port Manifold Block Dimension

ITEM	2	4	6	8	10
B	46.0	84.0	122.0	160.0	198.0
A	59.0	97.0	135.0	173.0	211.0

3Port Manifold Block Dimension

ITEM	2	4	6	8	10
B	46.0	84.0	122.0	160.0	198.0
A	59.0	97.0	135.0	173.0	211.0

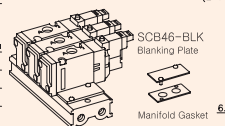

### Manifold Ordering Code

SCB4 1 - D - M04

Series	Port & Thread	Function	Manifold Station
SCB3	0 None	0 None	M02 2-Station
SC400 Solenoid Valve	1 G	S Single Station Sub Base, 1/4 Port Without Pilot Ports	M04 4-Station
	2 NPT	D Manifold, Port 1/4	M06 6-Station
		DB Double Modular Manifold Block, 1/4 Port	M08 8-Station
		DC8 Double Modular Manifold Block, Ø 8 Fitting	M10 10-Station
		D3 Manifold, Port 1/8 (3/2Way)	

### Single Station Sub Base Dimension (SCB41-S)

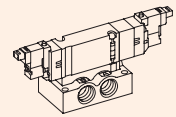

Ordering Code  
SCB46-BLK

- Blanking Plate (Material : STS304)
- Manifold Gasket (Material : NBR)

Ordering Code  
SCB40-BLK

- Blanking Plate (Material : STS304)
- Manifold Gasket (Material : NBR)



# SCE300.1/8

"E" ECONOMY Series  
Solenoid / Pneumatic Valves

- 5/2, 5/3-1/8, 3/2-M5 ■ 15mm Body Width
- Manifold or Sub-Base Type
- High Efficiency, Expense Reduction Type
- Transition Flow 500ℓ/min (5bar)

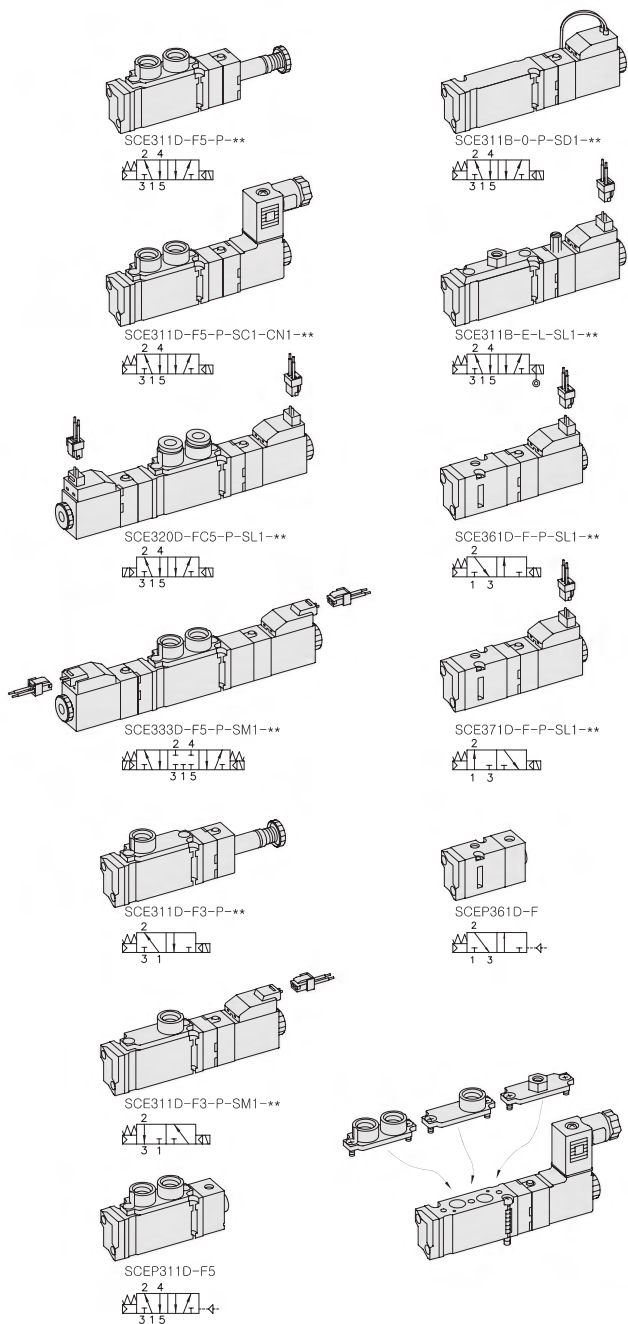

\*\*\*: Voltage Selection (see page 80)

## SPECIFICATION

ITEM	SERIES	SOLENOID, PNEUMATIC	
		5, 3Port 2Postion	5Port 3Postion
Fluids		Compressed Air & Inert Gases	
Pressure(bar)		1.5~10.0	2.0~10.0
Eff. Sectional Area(mm <sup>2</sup> )-5bar		9.5	7.5
Ambient & Fluid Temp.		5~60°C (41~140°F)	
Response Time(5bar)		25ms or Less	35ms or Less
Max. Working Frequency		8c/sec	5c/sec
Lubrication		Not Required(Use ISO VG32 #)	
Manual Override		Push Button(Standard), Lever Lock(Option)	
Coil Insulation Class		F-Class or Equivalent	
Permissible Voltage Variation		±10% of Rated Voltage	
Off Min. Residual Voltage		AC:20% or Less / DC:10% or Less	
Power Consumption		Holding-AC:3.5VA(60Hz) / DC:2.5W	

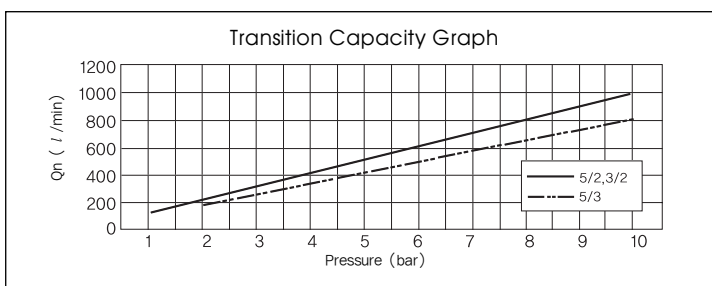

- ### The Material of Parts
- Valve Body : Die-Cast Aluminium
  - Spool : Aluminium
  - Seals : NBR
  - Spring : Stainless
  - Cap : Zinc Pressure Die-Cast
  - Pilot Parts : Glass Filled Nylon
  - Armature : Stainless Steel
  - Armature Seals : Viton

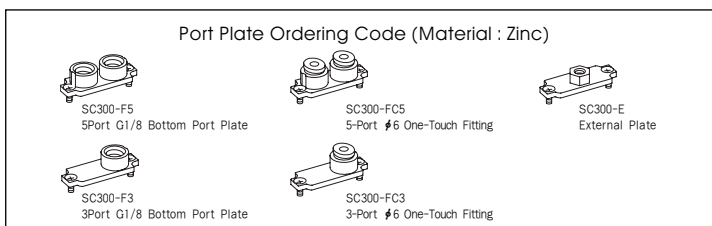

\* The specification on each item can be amended without any prenotice to improve a performance.  
\* The specification on each item can be different from actual specification.

## ORDERING NO.

**SCE3 1 1 D - F5 - P - SC1 - CN1 - D4**

Valve Series	Function	Return Method	Port Type	Port Plate & Thread	Manual Operator	Solenoid Coil Type	Connector Type	Voltage
SCE3 : Solenoid Valve	1	5/2 Single	0	None	D	Manifold	0	None
	2	5/2 Double	1	Air + Spring	B	Sub-Base	CN1	Normal Connector
	3	5/3 Closed Center	2	Air	F3	3-Port G1/8	SG1	Grommet/Flying Leads
	4	5/3 Open Center	3	Spring	FN5	5-Port NPT1/8	SD1	Grommet/Flying Leads With LED
SCEP3 : Pneumatic Valve	5	5/3 Pressure Center			L	Non-Locking		A1
	6	3/2 Normally Closed				Lever Locking		A2
	7	3/2 Normally Open						A4
								D4
								D2

# Solenoid & Pilot Actuated Spool Valves

## Port Thread 1/8, M5

### 5Port 2Position Solenoid Valve (Manifold)

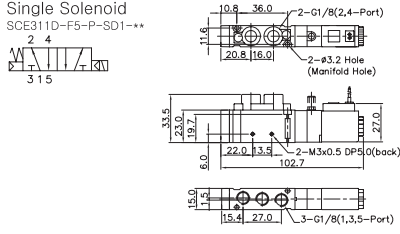

### Double Solenoid



### 5Port 3Position Solenoid Valve (Manifold)

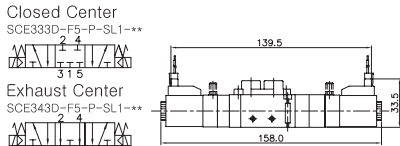

### 3Port 2Position Solenoid Valve (Manifold)

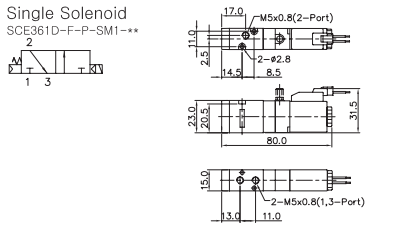

### 5Port 2Position Solenoid Valve (Sub-Base)

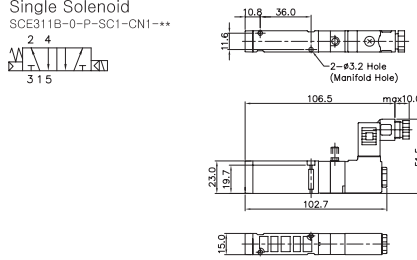

### Double Solenoid External Pilot

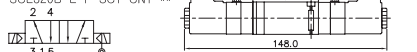

### 5Port 3Position Solenoid Valve (Sub-Base)

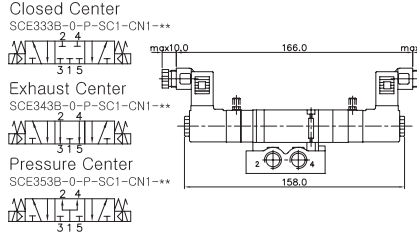

### 5Port 2Position Pneumatic Valve

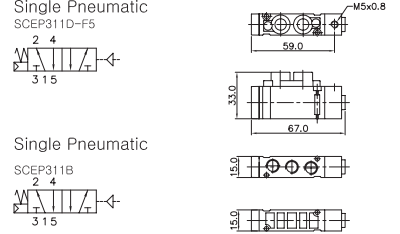

### Double Pneumatic



### 5Port 3Position Pneumatic Valve

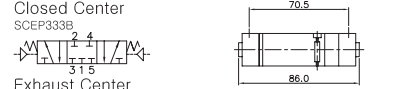

### 3Port 2Position Pneumatic Valve

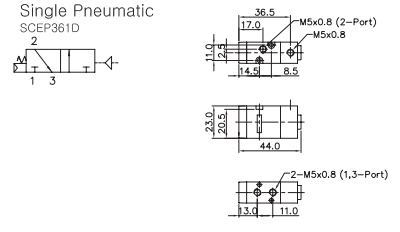

## SCB30 SINGLE, DOUBLE MANIFOLD BLOCK

(SCE300 Solenoid & Pneumatic Valve Use)

### Manifold Block Dimension

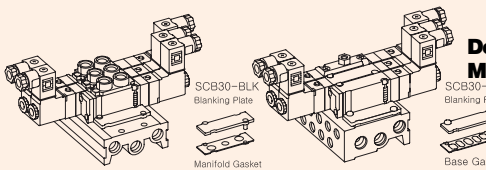

### Double Modular Manifold Block Dimension

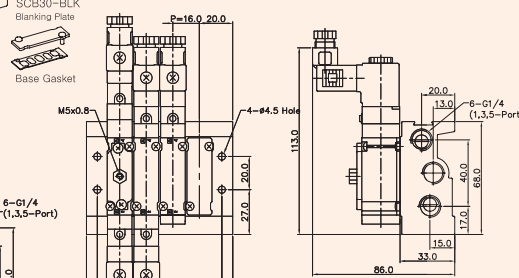

Double Modular Sub Base Dimension

ITEM	2	4	6	8	10
B	43.0	75.0	107.0	139.0	171.0
A	56.0	88.0	120.0	152.0	184.0

### Single Station Sub Base Dimension (SCB31-S)

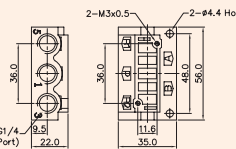
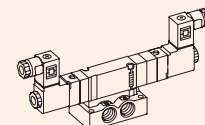

### 5Port Manifold Block Dimension

ITEM	2	4	6	8	10
B	40.0	72.0	104.0	136.0	168.0
A	53.0	85.0	117.0	149.0	181.0

### 3Port Manifold Block Dimension

ITEM	2	4	6	8	10
B	40.0	72.0	104.0	136.0	168.0
A	53.0	85.0	117.0	149.0	181.0

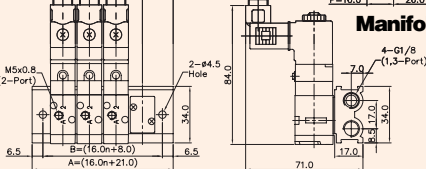

### Manifold Block Dimension

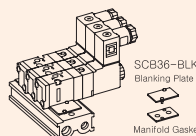
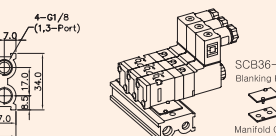

Ordering code  
SCB36-BLK  
Blanking Plate (Material : STS304)  
Manifold Gasket (Material : NBR)

Ordering Code  
SCB30-BLK  
Blanking Plate (Material : STS304)  
Manifold Gasket (Material : NBR)

### Manifold Ordering Code

SCB3 1 - D - M04

Series	Port & Thread	Function	Manifold Station
SCB3	0 None	0 None	M02 2-Station
SC300 Solenoid Valve	1 G	S Single Station Sub Base, 1/4 Port Without Pilot Ports	M04 4-Station
	2 NPT	D Manifold, Port 1/4	M06 6-Station
		DB Double Modular Manifold Block, 1/8 Port	M08 8-Station
		DC6 Double Modular Manifold Block, Ø6 Fitting	M10 10-Station
		D3 Manifold, Port 1/8 (3/2Way)	

# SCE400.1/4

"E" ECONOMY Series  
Solenoid / Pneumatic Valves

- 5/2, 5/3-1/4, 3/2-1/8 ■ 18mm Body Width
- Manifold or Sub-Base Type
- High Efficiency, Expense Reduction Type
- Transition Flow 900ℓ/min (5bar)

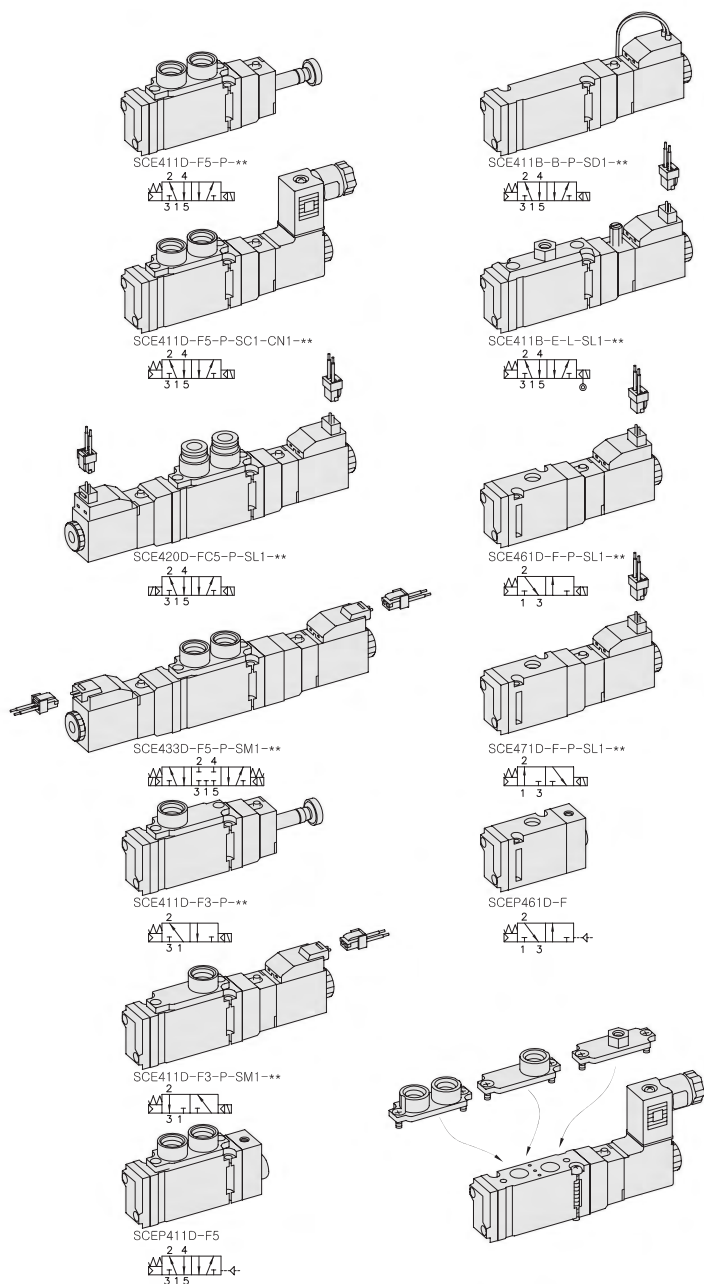

\*\* : Voltage Selection (see page 80)

## SPECIFICATION

ITEM	SERIES	SOLENOID, PNEUMATIC	
		5, 3Port 2Postion	5Port 3Postion
Fluids		Compressed Air & Inert Gases	
Pressure(bar)		1.5~10.0	2.0~10.0
Eff. Sectional Area(mm <sup>2</sup> )-5bar		16.0	12.0
Ambient & Fluid Temp.		5~60°C (41~140°F)	
Response Time(5bar)		25ms or Less	35ms or Less
Max. Working Frequency		5c/sec	3c/sec
Lubrication		Not Required(Use ISO VG32 #)	
Manual Override		Push Button(Standard), Lever Lock(Option)	
Coil Insulation Class		F-Class or Equivalent	
Permissible Voltage Variation		±10% of Rated Voltage	
Off Min. Residual Voltage		AC:20% or Less / DC:10% or Less	
Power Consumption		Holding-AC:3.5VA(60Hz) / DC:2.5W	

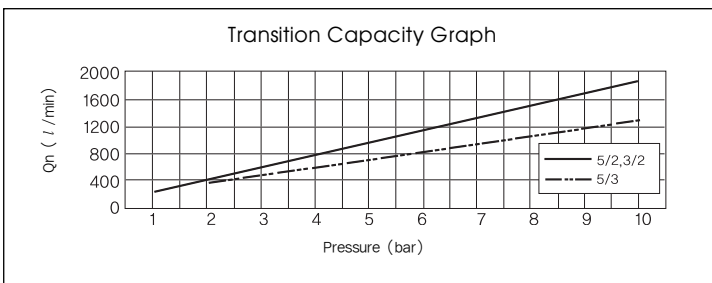

- ### The Material of Parts
- Valve Body : Die-Cast Aluminium
  - Spool : Aluminium
  - Seals : NBR
  - Spring : Stainless
  - Cap : Zinc Pressure Die-Cast
  - Pilot Parts : Glass Filled Nylon
  - Armature : Stainless Steel
  - Armature Seals : Viton

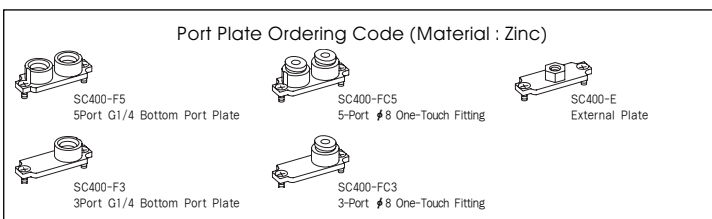

\* The specification on each item can be amended without any prenotice to improve a performance.  
\* The specification on each item can be different from actual specification.

## ORDERING NO.

**SCE4 1 1 D - F5 - P - SC1 - CN1 - D4**

Valve Series	Function	Return Method	Port Type	Port Plate & Thread	Manual Operator	Solenoid Coil Type	Connector Type	Voltage
SCE4 : Solenoid Valve	1	5/2 Single	0	None	D	Manifold	0	None
	2	5/2 Double	1	Air + Spring	B	Sub-Base	CN1	Normal Connector
	3	5/3 Closed Center	2	Air	F3	3-Port G1/4	SG1	Grommet / Flying Leads
SCEP4 : Pneumatic Valve	4	5/3 Open Center	3	Spring	FN5	5-Port NPT1/4	SD1	Grommet / Flying Leads With LED
	5	5/3 Pressure Center			FN3	3-Port NPT1/4	SL1	90 Degree Plug-in Wire Assembly with LED
	6	3/2 Normally Closed			FC5	5-Port #8 One-Touch Fitting	SM1	180 Degree Plug-in Wire Assembly with LED
	7	3/2 Normally Open			FC3	3-Port #8 One-Touch Fitting		
				E	External End Plate, Plate M5×0.8			

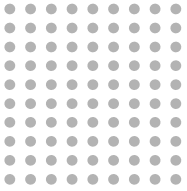

# Solenoid & Pilot Actuated Spool Valves

Port Thread 1/4, 1/8

## 5Port 2Position Solenoid Valve (Manifold)

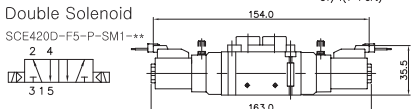
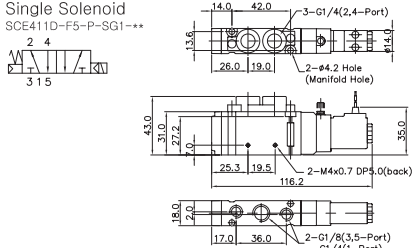

## 5Port 3Position Solenoid Valve (Manifold)

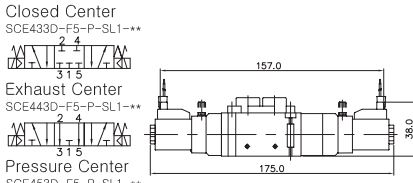

## 3Port 2Position Solenoid Valve (Manifold)

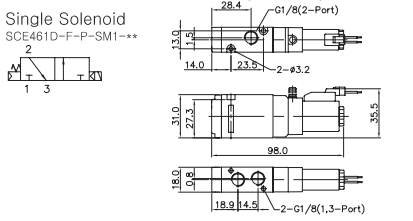

## 5Port 2Position Solenoid Valve (Sub-Base)

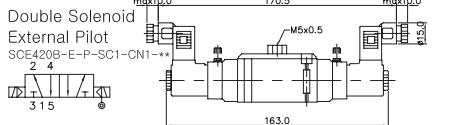
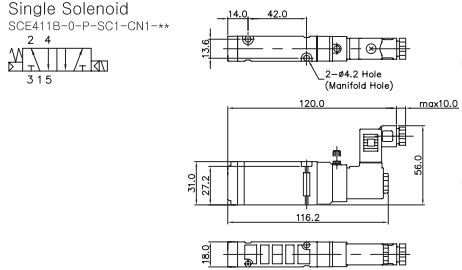

## 5Port 3Position Solenoid Valve (Sub-Base)

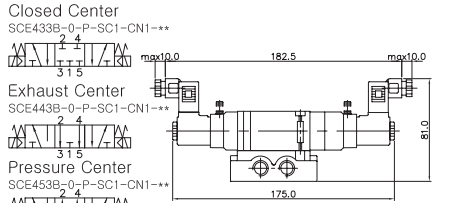

## 5Port 2Position Pneumatic Valve

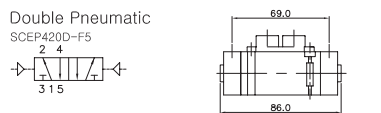
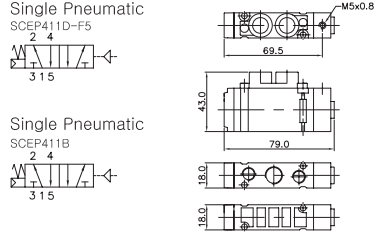

## 5Port 3Position Pneumatic Valve

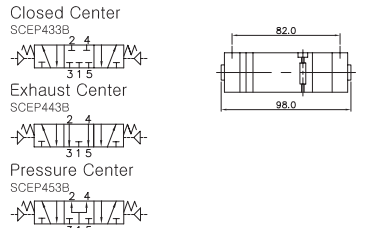

## 3Port 2Position Pneumatic Valve

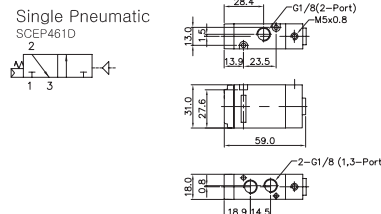

# SCB40 SINGLE, DOUBLE MANIFOLD BLOCK

(SCE400 Solenoid & Pneumatic Valve Use)

## Manifold Block Dimension

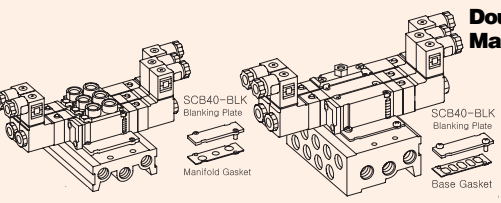

## Double Modular Manifold Block Dimension

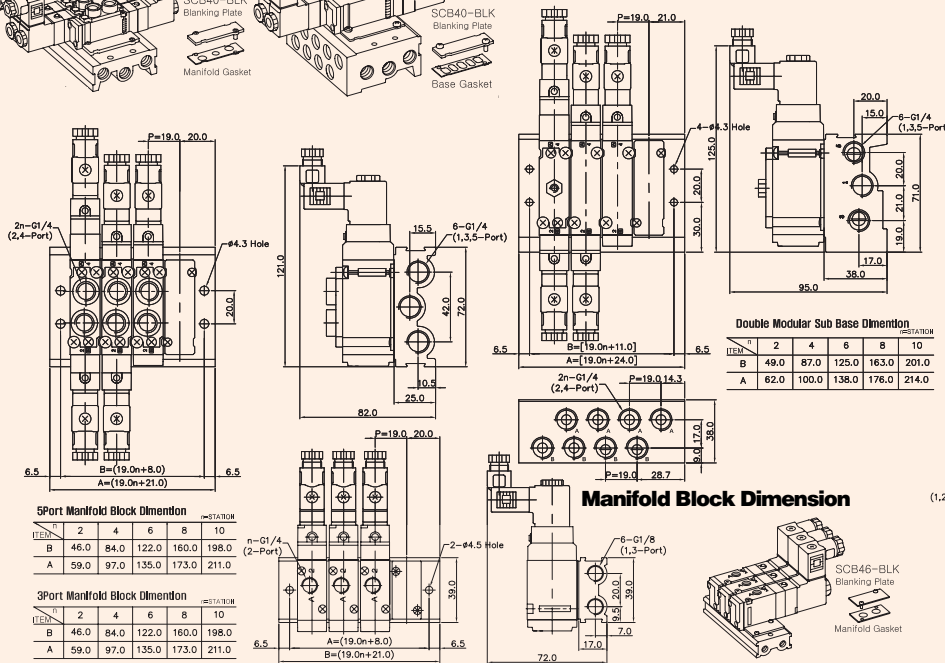

## Manifold Ordering Code

SCB4 1 - D - M04

Series	Port & Thread	Function	Manifold Station
SCB4	0 None	0 None	M02 2-Station
SC400 Solenoid Valve	1 G	S Single Station Sub Base, 1/4 Port Without Pilot Ports	M04 4-Station
	2 NPT	D Manifold, Port 1/4	M06 6-Station
		DB Double Modular Manifold Block, 1/4 Port	M08 8-Station
		DC8 Double Modular Manifold Block, Ø 8 Fitting	M10 10-Station
		D3 Manifold, Port 1/8 (3/2Way)	

## Single Station Sub Base Dimension (SCB41-S)

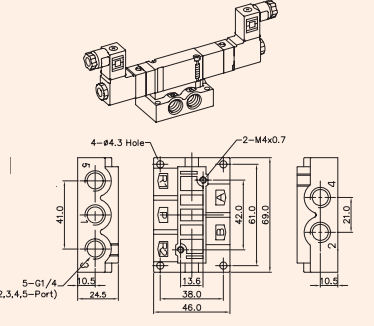

Ordering Code SCB46-BLK Blanking Plate (Material : STS304)	Ordering Code SCB40-BLK Blanking Plate (Material : STS304) Manifold Gasket. Base Gasket. (Material : NBR)
---	---



# SCE500. 3/8

"E" ECONOMY Series  
Solenoid / Pneumatic Valves

- 5/2, 5/3, 3/2-3/8 ■ 26mm Body Width
- Sub-Base or Manifold Mounting Type
- High Efficiency, Expense Reduction Type
- Transition Flow 2200ℓ/min (5bar)

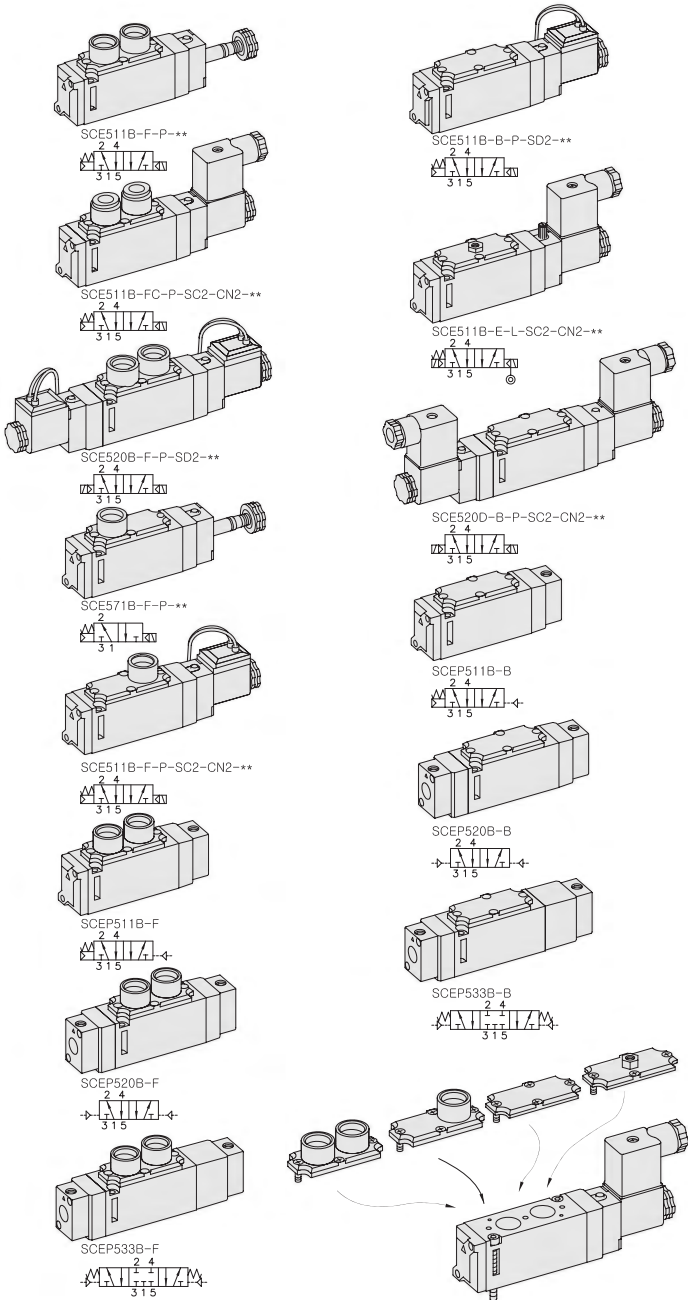

\*\* : Voltage Selection (see page 60)

## SPECIFICATION

ITEM	SERIES	SOLENOID, PNEUMATIC	
		FUNCTION	
		5, 3 Port 2 Position	5 Port 3 Position
Fluids		Compressed Air & Inert Gases	
Pressure(bar)		1.5~10.0	2.0~10.0
Eff. Sectional Area(mm <sup>2</sup> )-5bar		40.0	30.0
Ambient & Fluid Temp.		5~60°C (41~140°F)	
Response Time(5bar)		30ms or Less	40ms or Less
Max. Working Frequency		5c/sec	3c/sec
Lubrication		Not Required(Use ISO VG32 #)	
Manual Override		Push Button(Standard), Lever Lock(Option)	
Coil Insulation Class		F-Class or Equivalent	
Permissible Voltage Variation		±10% of Rated Voltage	
Off Min. Residual Voltage		AC:20% or Less / DC:10% or Less	
Power Consumption		Holding-AC:5.5VA(60Hz) / DC:2.5W	

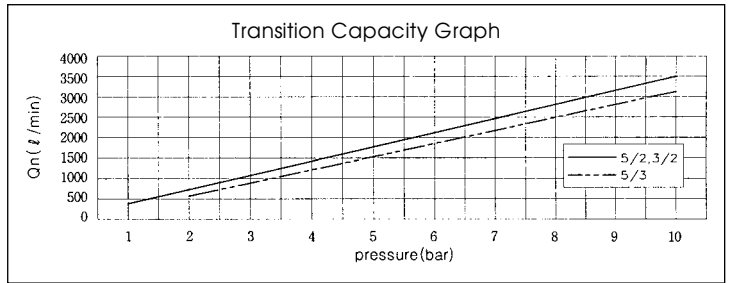

- ### The Material of Parts
- Valve Body : Die-Cast Aluminium
  - Spool : Aluminium
  - Seals : NBR
  - Spring : Stainless
  - Cap : Zinc Pressure Die-Cast
  - Pilot Parts : Glass Filled Nylon
  - Armature : Stainless Steel
  - Armature Seals : Viton

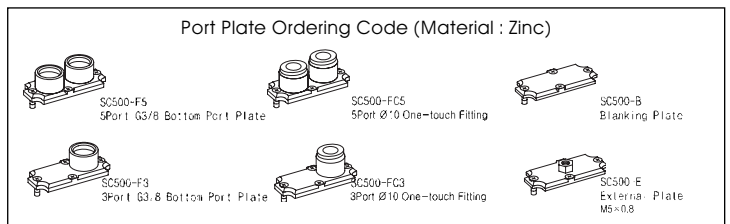

\* The specification on each item can be amended without any prenotice to improve a performance.  
\* The specification on each item can be different from actual specification.

## ORDERING NO.

**SCE5 1 1 B - F - P - SC2 - CN2 - D4**

Valve Series	Function	Return Method	Port Type	Port Plate & Thread	Manual Operator	Solenoid Coil Type	Connector Type	Voltage		
SCE5 : Solenoid Valve	1	5/2 Single	0	None	D	Manifold	F	G3/8	0	None
	2	5/2 Double	1	Air + Spring	B	Sub-Base	FN	NPT 3/8	P	Push
	3	5/3 Closed Center	2	Air	FC	Ø10 One-Touch Fitting	SG2	Grommet / Flying Leads	CD2	Connector With LED
	4	5/3 Open Center	3	Spring	B	Blanking End Plate	SD2	Grommet / Flying Leads With LED	CZ2	Connector With LED & Surge Suppressor
SCEP5 : Pneumatic Valve	5	5/3 Pressure Center			E	External End Plate, Plate M5x0.8			A1	AC 110V
	6	3/2 Normally Closed							A4	AC 24V
	7	3/2 Normally Open							D4	DC 24V
									D2	DC 12V

# Solenoid & Pilot Actuated Spool Valves

## Port Thread 3/8

### 5Port 2Position Solenoid Valve (Manifold)

Single Solenoid  
SCE511D-B-P-SG2-\*\*\*

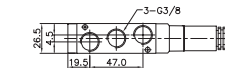
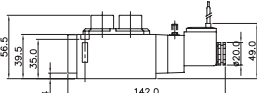
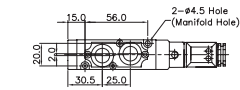
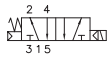

Double Solenoid  
SCE520B-F-P-SG2-\*\*\*

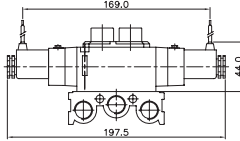
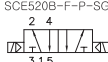

### 5Port 2Position Solenoid Valve (Sub-Base)

Single Solenoid  
SCE511B-B-P-SC2-CN2-\*\*\*

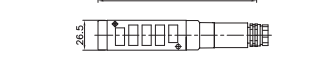
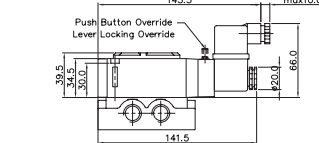
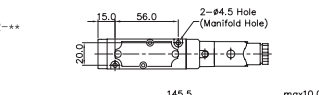
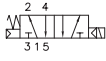

Double Solenoid  
External Pilot  
SCE520B-E-P-SC2-CN2-\*\*\*

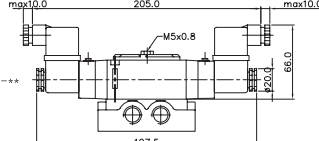
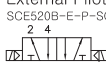

### 5Port 2Position Pneumatic Valve

Single Pneumatic  
SCEP511B-F

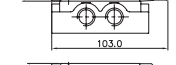
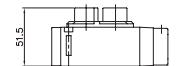
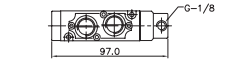

Single Pneumatic  
SCEP511B-B

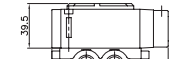
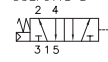

Double Pneumatic  
SCEP520B-F

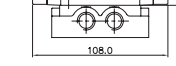
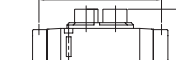

### 5Port 3Position Solenoid Valve (Manifold)

Closed Center  
SCE533B-F-P-SG2-\*\*\*

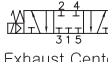

Exhaust Center  
SCE543B-F-P-SG2-\*\*\*

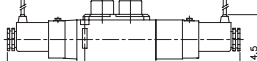

Pressure Center  
SCE553B-F-P-SG2-\*\*\*

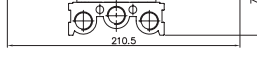

### 5Port 3Position Solenoid Valve (Sub-Base)

Closed Center  
SCE533B-B-P-SC2-CN2-\*\*\*

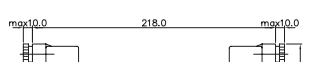
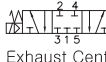

Exhaust Center  
SCE543B-B-P-SC2-CN2-\*\*\*

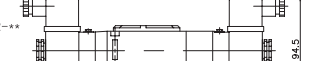

Pressure Center  
SCE553B-B-P-SC2-CN2-\*\*\*



### 5Port 3Position Pneumatic Valve

Closed Center  
SCEP532B-B

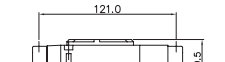
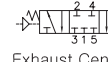

Exhaust Center  
SCEP542B-B

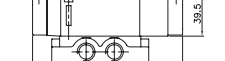
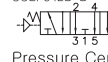

Pressure Center  
SCEP552B-B

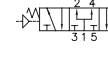

## SCB50 SINGLE, DOUBLE MANIFOLD BLOCK

(SCE500 Solenoid & Pneumatic Valve Use)

### Manifold Block Dimension

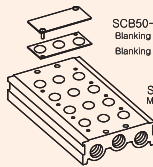
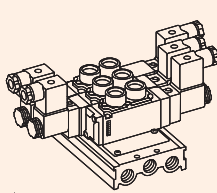

SCB50-BLK  
Blanking Plate  
Blanking Plate Gasket

SCB51-D-M04  
Manifold Block

### Double Modular Sub Base Dimension

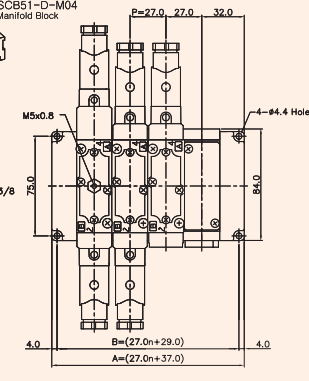

### Manifold Ordering Code

SCB5 1 - D - M04			
Series	Port & Thread	Function	Manifold Station
SCB5	0 None	0 None	M02 2-Station
SCE500 Solenoid Valve	1 G	S Single Station Sub Base, 3/8 Port Without Pilot Ports	M04 4-Station
	2 NPT	D Manifold, Port 3/8	M06 6-Station
		DB Double Modular Sub Base, 3/8 Port Without Pilot Ports	M08 8-Station
		DC10 Double Modular Sub Base, ø 10 Fitting	M10 10-Station
		E End Cover, 3/8 Port	
		EB End Blanking Cover	

ITEM	2	4	6	8	10
B	83.0	137.0	191.0	245.0	299.0
A	91.0	145.0	199.0	253.0	307.0

### 5Port Manifold Block Dimension

ITEM	2	4	6	8	10
B	71.5	126.5	181.5	236.5	291.5
A	83.5	138.5	193.5	248.5	303.5

### Single Station Sub Base Dimension

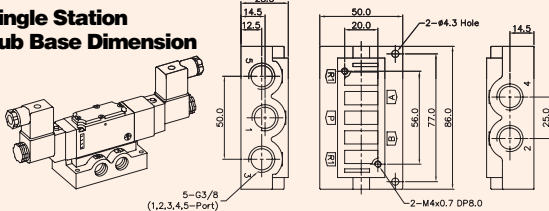

Ordering Code  
SCB50-DC10

Double Modular  
Sub Base  
ø10 one-touch  
fitting  
(Material: Al)

Ordering Code  
SCB51-DB

Double Modular  
Sub Base, 3/8  
(Material: Al)

Ordering Code  
SCB50-BLK

Blanking Plate  
(Material: STS304)  
Manifold Gasket,  
Base Gasket,  
(Material: NBR)

Ordering Code  
SCB51-E

End Cover, 3/8  
(Material: Al)

Ordering Code  
SCB50-EB

End Blanking  
Cover  
(Material: Al)





# SN (NAMUR) Series

5/2, 5/3 Solenoid, Pneumatic Valve

## CHAPTER 07

- SN3000
- SN4000



SN3000  
Body Width-23mm  
Thread-1/4



SN4000  
Body Width-30mm  
Thread-1/4

# SN3000. 1/4

NAMUR Interface  
Solenoid / Pneumatic Valves

- 5/2, 5/3 -1/4
- 23mm Body Width
- Transition Flow 1000ℓ/min (5bar)

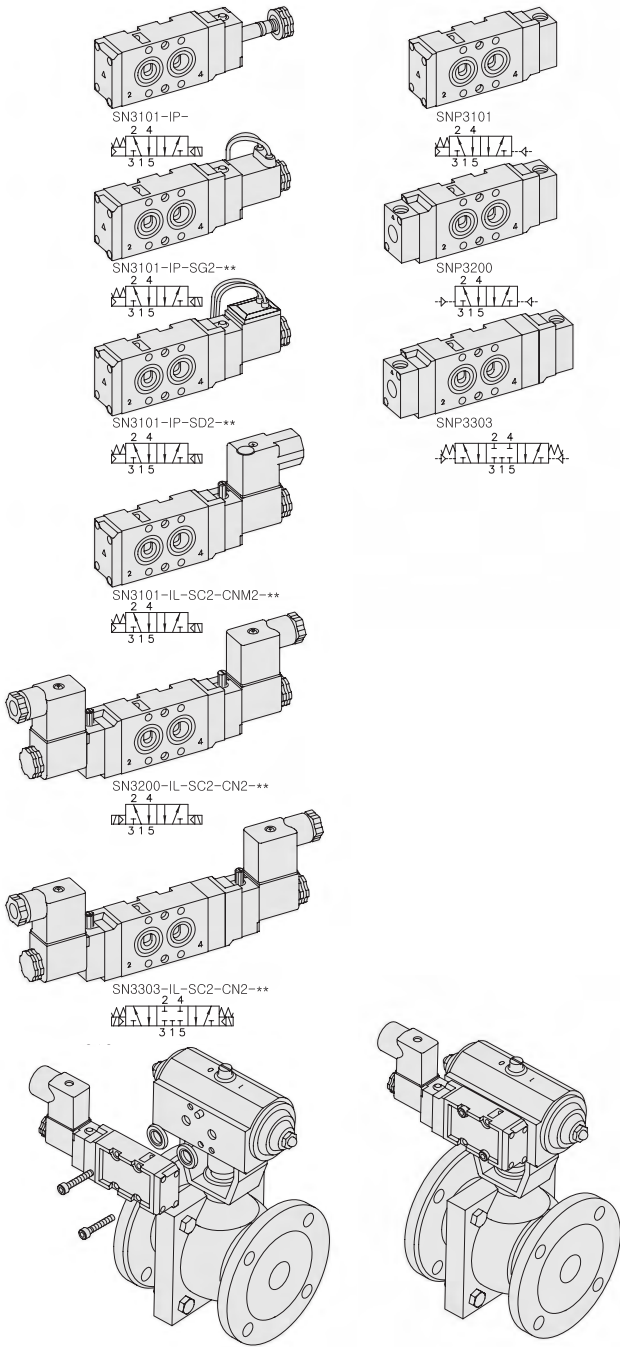

## SPECIFICATION

ITEM	SERIES	SOLENOID, PNEUMATIC	
		5 Port 2 Position	5 Port 3 Position
Fluids		Compressed Air & Inert Gases	
Pressure(bar)		1.5~10.0	2.0~10.0
Eff. Sectional Area(mm <sup>2</sup> )-5bar		18.0	12.0
Ambient & Fluid Temp.		5~60°C (41~140°F)	
Response Time(5bar)		30ms or Less	40ms or Less
Max. Working Frequency		5c/sec	3c/sec
Lubrication		Not Required(Use ISO VG32 #)	
Manual Override		Push Button(Standard), Lever Lock(Option)	
Coil Insulation Class		F-Class or Equivalent	
Permissible Voltage Variation		±10% of Rated Voltage	
Off Min. Residual Voltage		AC:20% or Less / DC:10% or Less	
Power Consumption		Holding-AC:5.5VA(60Hz) / DC:2.5W	

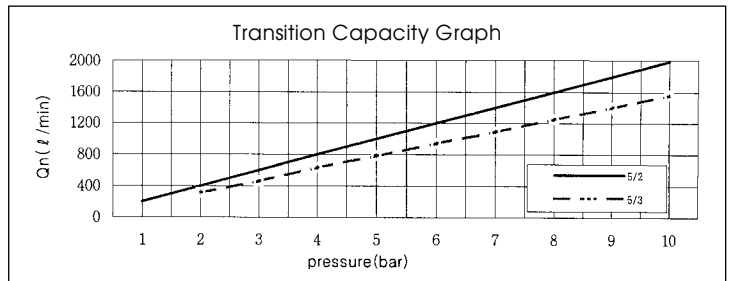

- ### The Material of Parts
- Valve Body : Die-Cast Aluminium
  - Spool : Aluminium
  - Seals : NBR
  - Spring : Stainless
  - Cap : Zinc Pressure Die-Cast
  - Pilot Parts : Glass Filled Nylon
  - Armature : Stainless Steel
  - Armature Seals : Viton

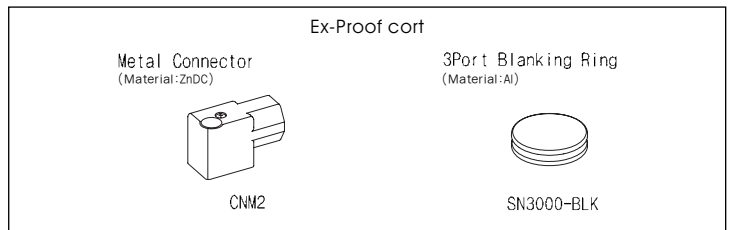

\* The specification on each item can be amended without any prenotice to improve a performance.  
\* The specification on each item can be different from actual specification.

## ORDERING NO.

**SN3 1 0 1 - I P - SC2 - CN2 - A2**

Valve Series	Function	Port Size & Thread	Return Method	Int/Ext. Pilot	Manual Operator	Solenoid Coil Type	Connector Type	Voltage
SN3 : Solenoid Valve	1 5/2 Single	0 G 1/4	0 None	I Internal Pilot	O None	O None	O None	O None
	2 5/2 Double	1 NPT 1/4	1 Air + Spring		P Push	SC2 3 Pin Connector Coil	CN2 Normal Connector	A2 AC 220V
	3 5/3 Closed Center		2 Air		Non-Locking	SG2 Grommet/Flying Leads	CD2 Connector With LED	A1 AC 110V
	4 5/3 Open Center		3 Spring		L Lever Locking	SD2 Grommet/Flying Leads With LED	C22 Connector With LED & Surge Suppressor	A4 AC 24V D4 DC 24V D2 DC 12V
SNP3 : Pneumatic Valve	5 5/3 Pressure Center						CNM2 Metal Connector CDM2 Metal Connector With LED C2M2 Metal Connector With LED & Surge Suppressor	

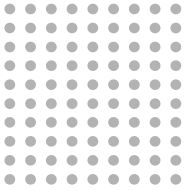

# Solenoid & Pilot Actuated Spool Valves

## 5Port 2Position Solenoid Valve

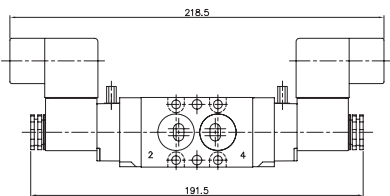
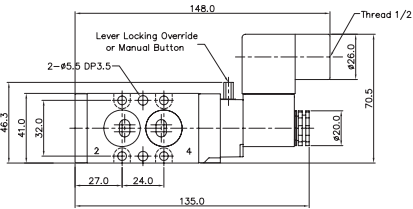
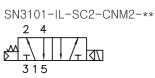
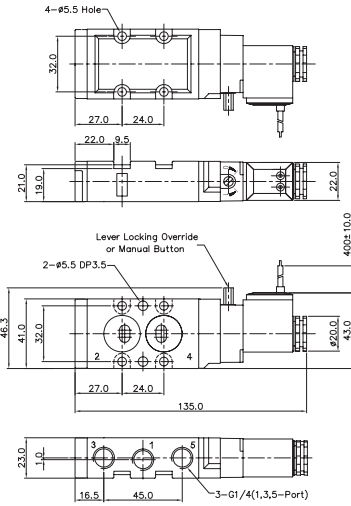
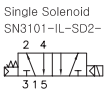

## 5Port 3Position Solenoid Valve

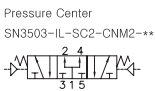
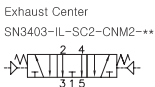
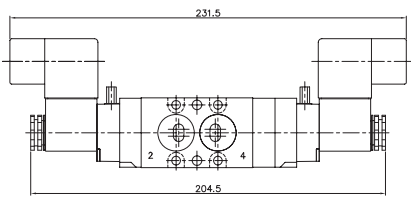
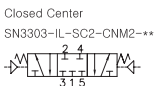

## 5Port 2Position Pneumatic Valve

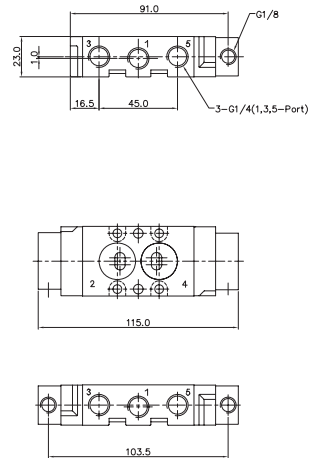
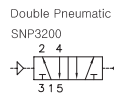
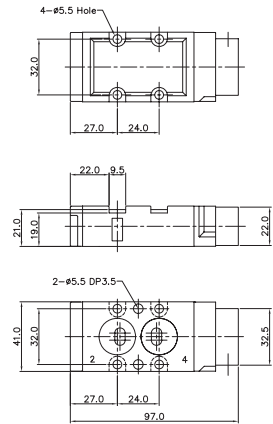
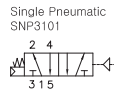

## 5Port 3Position Pneumatic Valve

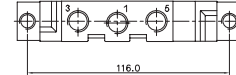
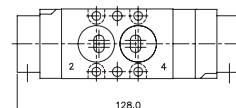
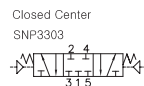

## Sealing Part Dimension

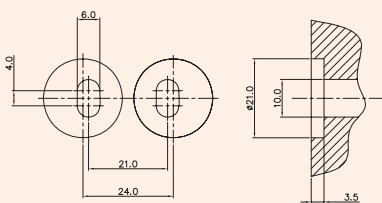

Sealing Area

## 3-Port Blanking Part (Material : Al)

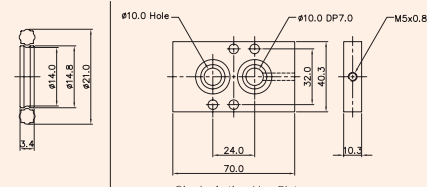

SN3000-BLK

Single Acting Use Plate  
 SN3000-Plate

## Metal Connector (Material : ZnDC)

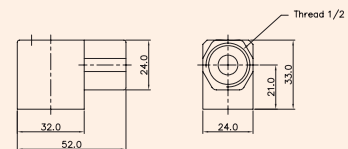

CNM2

# SN4000. 1/4

NAMUR Interface  
Solenoid / Pneumatic Valves

- 5/2, 5/3-1/4
- 30mm Body Width
- Transition Flow 1800ℓ/min (5bar)

## SPECIFICATION

ITEM	SERIES	SOLENOID, PNEUMATIC	
		5 Port 2 Position	5 Port 3 Position
Fluids		Compressed Air & Inert Gases	
Pressure(bar)		1.5~10.0	2.0~10.0
Eff. Sectional Area(mm <sup>2</sup> )-5bar		32.0	16.0
Ambient & Fluid Temp.		5~60°C (41~140°F)	
Response Time(5bar)		30ms or Less	40ms or Less
Max. Working Frequency		5c/sec	3c/sec
Lubrication		Not Required(Use ISO VG32 #)	
Manual Override		Push Button(Standard), Lever Lock(Option)	
Coil Insulation Class		F-Class or Equivalent	
Permissible Voltage Variation		±10% of Rated Voltage	
Off Min. Residual Voltage		AC:20% or Less / DC:10% or Less	
Power Consumption		Holding-AC:5.5VA(60Hz) / DC:2.5W	

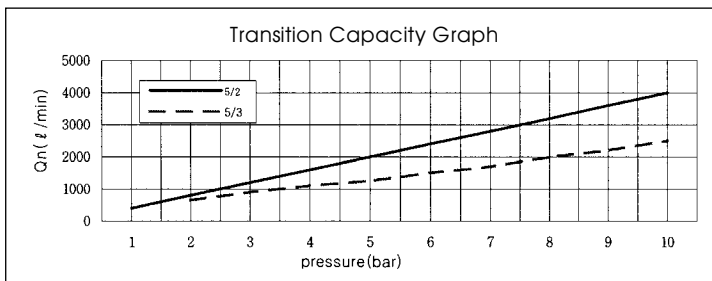

- ### The Material of Parts
- Valve Body : Die-Cast Aluminium
  - Spool : Aluminium
  - Seals : NBR
  - Spring : Stainless
  - Cap : Zinc Pressure Die-Cast
  - Pilot Parts : Glass Filled Nylon
  - Armature : Stainless Steel
  - Armature Seals : Viton

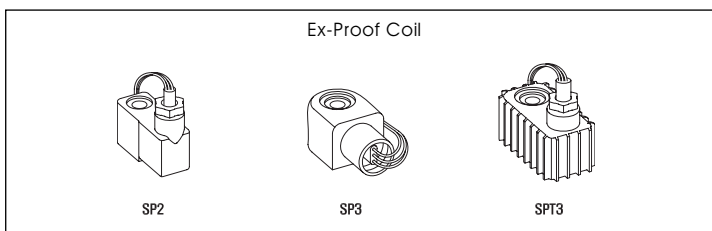

\* The specification on each item can be amended without any prenotice to improve a performance.  
\* The specification on each item can be different from actual specification.

## ORDERING NO.

**SN4 1 0 1 - I P - SC2 - CN2 - A2**

Valve Series	Function	Port Size & Thread	Return Method	Int/Ext. Pilot	Manual Operator	Solenoid Coil Type	Connector Type	Voltage
SN4 : Solenoid Valve	1 5/2 Single	0 G 1/4	0 None	I Internal Pilot	0 None	0 None	0 None	0 None
	2 5/2 Double	1 NPT 1/4	1 Air + Spring		P Push	SC2 3 Pin Connector Coil	CN2 Normal Connector	A2 AC 220V
	3 5/3 Closed Center		2 Air			SG2 Grommet/Flying Leads	CD2 Connector With LED	A1 AC 110V
	4 5/3 Open Center		3 Spring		L Lever Locking	SD2 Grommet/Flying Leads With LED	CZ2 Connector With LED & Surge Suppressor	A4 AC 24V
SNP4 : Pneumatic Valve	5 5/3 Pressure Center					SP2 22mm 방폭코일	CNM2 Metal Connector	D4 DC 24V
						SP3 36mm 방폭코일	CDM2 Metal Connector With LED	D2 DC 12V
						SPT3 36mm 방폭코일	CZM2 Metal Connector With LED & Surge Suppressor	

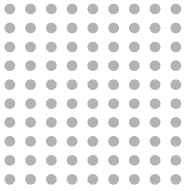

# Solenoid & Pilot Actuated Spool Valves

## 5Port 2Position Solenoid Valve

Single Solenoid

SN4101-IL-SD2-

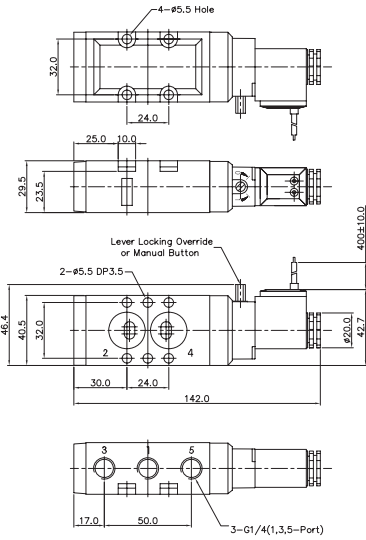

SN4101-IL-SC2-CNM2-\*

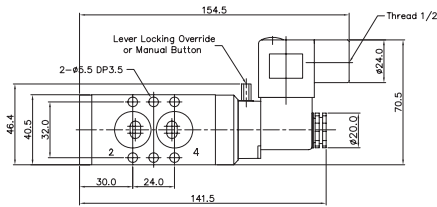

Double Solenoid

SN4200-IL-SC2-CNM2-\*

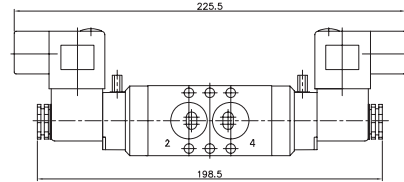
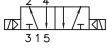

## 5Port 3Position Solenoid Valve

Closed Center

SN4303-IL-SC2-CNM2-\*

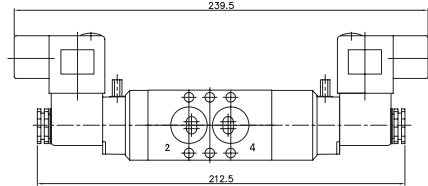
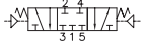

Exhaust Center

SN4403-IL-SC2-CNM2-\*

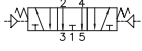

Pressure Center

SN4503-IL-SC2-CNM2-\*

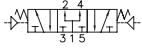

## 5Port 2Position & 3Position Pneumatic Valve

Single Pneumatic

SNP4101

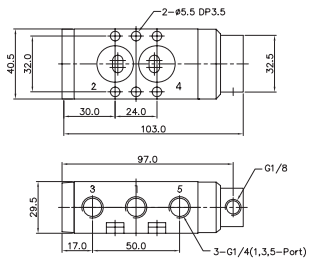
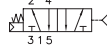

Double Pneumatic

SNP4200

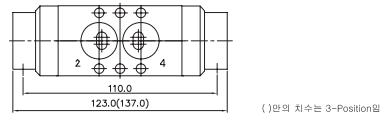

( ) 안의 치수는 3-Position임

## 5Port 2Position Ex-proof Solenoid Valve

Single Solenoid

SN4101-IP-SP2-\*\*\*

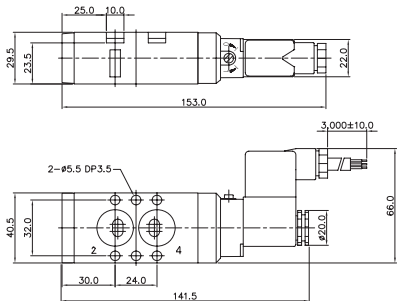
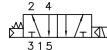

SN4101-IP-SP3-\*\*\*

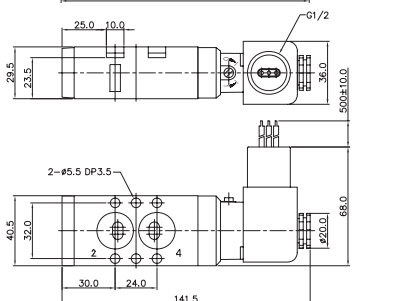
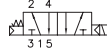

SN4101-IP-SPT3-\*\*\*

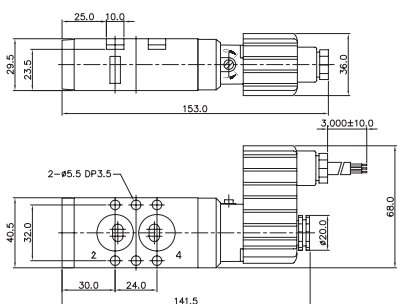
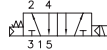

## Sealing Part Dimension

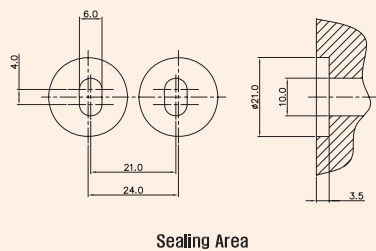

Sealing Area

## 3-Port Blanking Part (Material : AI)

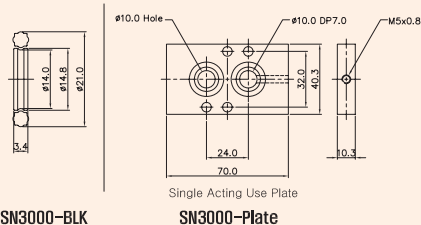

SN3000-BLK

SN3000-Plate  
Single Acting Use Plate

## Metal Connector (Material : ZnDC)

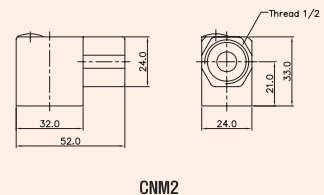

CNM2

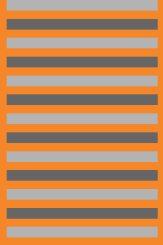

# Solenoid Coil Series CHAPTER 08

- A Wide Range of Option
- Various Voltage Specification
- 15mm Coil Width
- 22mm Coil Width



SC1-\*\*-  
IP65(With Connector)



SC2-\*\*-  
IP65(With Connector)



SG1-\*\*-  
IP65



SG2-\*\*-  
IP65



SD1-\*\*-  
IP42  
Indicator : LED



SD2-\*\*-  
IP42  
Indicator : LED



SL1-\*\*-  
IP42  
Indicator : LED



SM1-\*\*-  
IP42  
Indicator : LED

\*\* : Voltage Selection

## SPECIFICATION

ITEM	FUNCTION	SOLENOID COIL		
		SC1	SC2	
Voltage Tolerances		±10% of Rated Voltage		
Coil Insulation Class		F-Class or Equivalent		
Temperature Range		5~60°C (41~140°F)		
Holding Power	AC	60Hz	3.5VA	5.5VA
		50Hz	4.5VA	6.5VA
	DC	2.5W	2.5W	

### The Material of Parts

- Molding : Glass Pressure Nylon
- Lead Wire : AWC-no.22, no.24
- Lead Wire Packing : Viton
- Yoke : Carbon Iron
- Indicator Cap : Polycarbonate

※ The specification on each item can be amended without any prenotice to improve a performance.  
 ※ The specification on each item can be different from actual specification.

## ORDERING NO.

SC1 - A2

Solenoid Coil Type	
SC1	15mm-3 Pin Connector Coil
SG1	15mm-Grommet/Flying Leads
SD1	15mm-Grommet/Flying Leads With LED
SL1	15mm-90 Degree Plug-in Wire Assembly LED
SM1	15mm-180 Degree Plug-in Wire Assembly LED
SC2	22mm-3 Pin Connector Coil
SG2	22mm-Grommet/Flying Leads
SD2	22mm-Grommet/Flying Leads With LED

Voltage	
A2	AC 220V
A1	AC 110V
A4	AC 24V
D4	DC 24V
D2	DC 12V

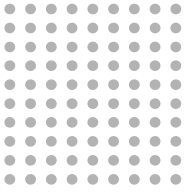

Solenoid Coil Series

15mm Width / 22mm Width

**SC1-\*\*-**  
(3Pin Connector Coil)

**SC2-\*\*-**  
(3Pin Connector Coil)

**SG1-\*\*-**  
(Grommet/Flying Leads)

**SG2-\*\*-**  
(Grommet/Flying Leads)

**SD1-\*\*-**  
(180 Degree Plug-in Wire Assembly LED)

**SD2-\*\*-**  
(Grommet/Flying Leads With LED)

**SL1-\*\*-**  
(90 Degree Plug-in Wire Assembly LED)

**SM1-\*\*-**  
(180 Degree Plug-in Wire Assembly LED)



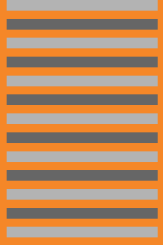

# DIN Connector Series

- A Wide Range of Option
- Various Voltage Specification
- 15mm Coil Width
- 22mm Coil Width

## SPECIFICATION

ITEM	FUNCTION	Connector	
		CN1	CN2
Voltage Tolerances		±10% of Rated Voltage	
Temperature Range		5~60°C (41~140°F)	
Max. Current		2.5A	
Protection Class		IP65(With Coil)	
Section Conductance		Max. 0.75mm <sup>2</sup>	Max. 1.50mm <sup>2</sup>

### The Material of Parts

- Indicator : Glass Pressure Nylon, Polycarbonate
- Sealing Packing : NBR
- Jointing Bolt : Carbon Iron

\* The specification on each item can be amended without any prenotice to improve a performance.  
 \* The specification on each item can be different from actual specification.



CN1



CN2



CD1-\*\*\*



CD2-\*\*\*



CZ1-\*\*\*



CZ2-\*\*\*



\*\*\*: Voltage Selection

## ORDERING NO.

**CD1 - A2**

### Connector Type

CN1	15mm-3 Pin Normal Connector
CD1	15mm-3 Pin Connector With LED
CZ1	15mm-3 Pin Connector With LED & Surge Suppressor
CN2	22mm-3 Pin Normal Connector
CD2	22mm-3 Pin Connector With LED
CZ2	22mm-3 Pin Connector With LED & Surge Suppressor
CNM2	24mm-3 Pin Metal Normal Connector
CDM2	24mm-3 Pin Metal Connector With LED
CZM2	24mm-3 Pin Metal Connector With LED & Surge Suppressor

### Voltage

A2	AC 220V
A1	AC 110V
A4	AC 24V
D4	DC 24V
D2	DC 12V

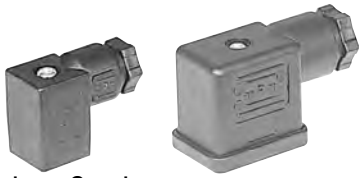
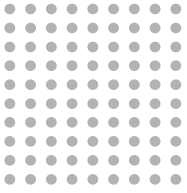

# DIN Connector Series

# 15mm Width / 22mm Width

**CN1**  
(Normal Connector)

**CD1-\*\***  
(Connector With Connector)

**CZ1-\*\***  
(Connector With Connector & Surge Suppressor)

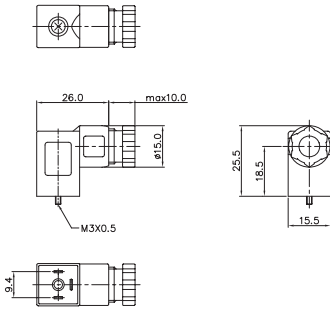

**CN2**  
(Normal Connector)

**CD2-\*\***  
(Connector With Connector)

**CZ2-\*\***  
(Connector With Connector & Surge Suppressor)

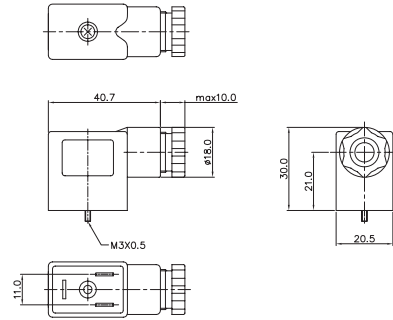

**CNM2**  
Metal Connector

**CDM2-\*\***  
Metal Connector With LED

**CZM2-\*\***  
Metal Connector With LED & Surge Suppressor

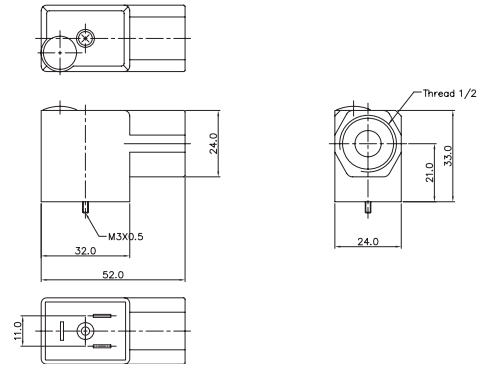



**YMV** Series  
**PMEV** Series  
**RLV** Series  
**HLV** Series  
**KMV** Series  
**TMV** Series  
**FT** Series

**CHAPTER 09**



**YMV Series** (3/2 Mechanically Valve)



**PMEV Series**  
 (5/2, 3/2 Panel Mounted Mechanically Valve)

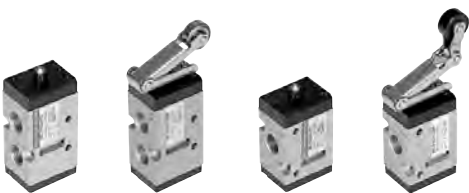

**RLV Series**  
 (5/2, 3/2 Roller Lever Mechanically Valve)



**HLV Series**  
 (5/2, 5/3, 3/2 Hand Lever Operated Spool Valve)



**KMV Series**  
 (5/2, 3/2 Knob push /Pull Manually Valve)



**TMV Series**  
 (5/2, 3/2 Toggle Lever Mechanically Valve)



**FT Series**  
 (5/2 Foot Treadle Operated Spool Valve)

# YMV Series

Manually & Mechanically Actuated Spool Valves

- 3/2
- Direct Operation Type
- A Wide Range of Option available
- Simple Panel Mounting

## SPECIFICATION

ITEM	SERIES	YMV310	YMV410
FUNCTION		3/2-Way	
Fluids		Compressed Air & Inert Gases	
Port Size		1/8	1/4
Pressure(bar)		0~8.0	
Eff. Sectional Area(mm <sup>2</sup> )-5bar		10.5	16.0
Ambient & Fluid Temp.		5~60°C (41~140°F)	
Lubrication		Not Required(Use ISO VG32#)	

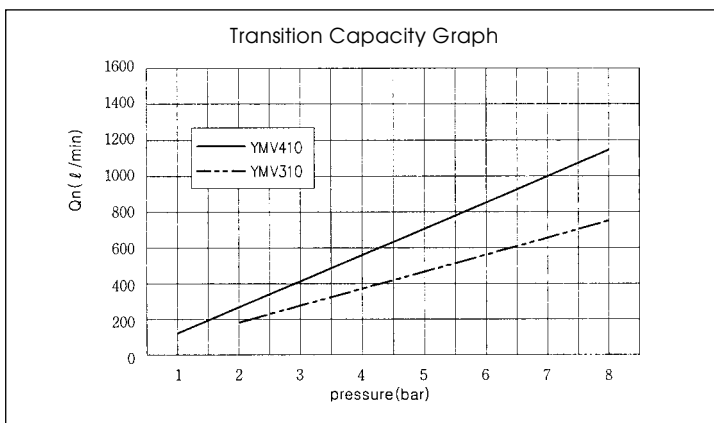

- ### The Material of Parts
- Valve Body : Die-Cast Aluminium
  - Spool : Aluminium
  - Seals : NBR
  - Spring : Stainless
  - Button Parts : Stainless Steel, POM
  - Switch Parts : Glass Filled Nylon, POM

※ The specification on each item can be amended without any prenotice to improve a performance.  
 ※ The specification on each item can be different from actual specification.

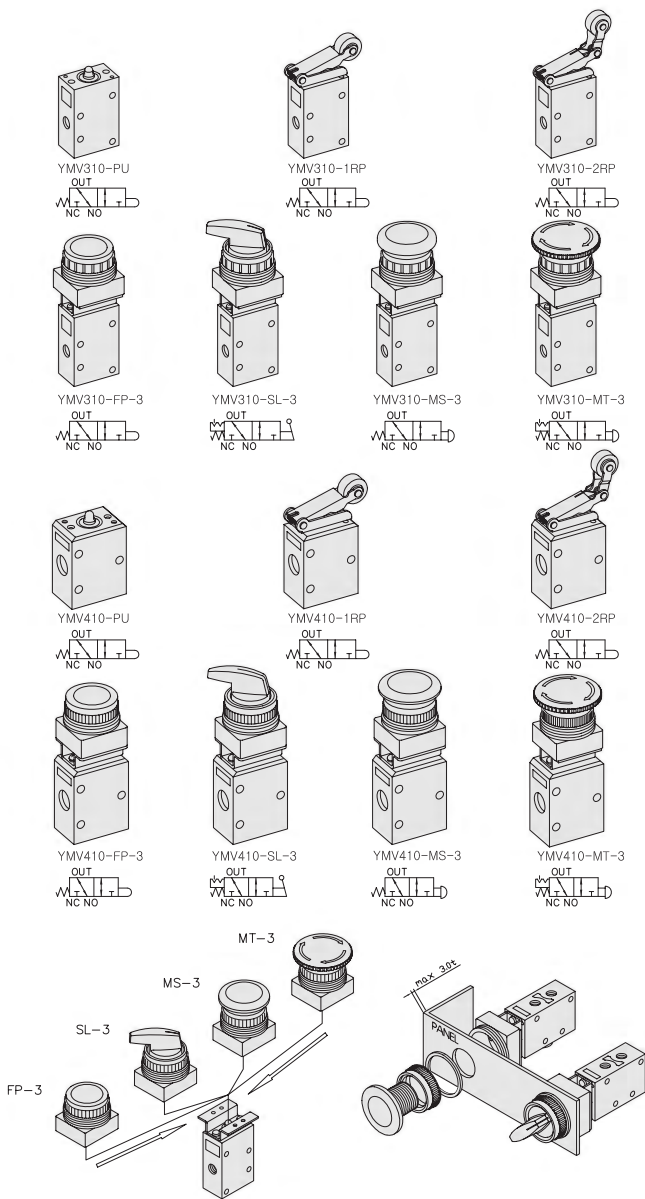

## ORDERING NO.

YMV3 1 0 - FP - 3

Valve Series	Function	Port Size & Thread	Switch Type	Mounting Holes
YMV3: 1/8-Port Body  YMV4: 1/4-Port Body	1   3/2 - Spring Return	0   G 1   NPT	PU   Pushrod 1RP   Two-way Plastic Roller Lever 1RB   Two-way Bearing Roller Lever 2RP   One-way Plastic Roller Lever 2RB   One-way Bearing Roller Lever FP   Flush, Push Button (R) SL   2-Position Selector (B) MS   Mushroom 40mm dia Spring Return (R) MT   Mushroom 40mm dia Turn to Unlock (R)	3   30mm

( ) Standard Color

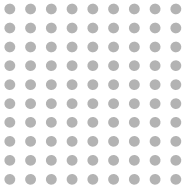

# Manually & Mechanically Actuated Spool Valves

## Port Thread 1/8, 1/4

### 3/2-Way, Direct Pushrod Operation Thread-1/8

T <sub>1</sub>	Valid Operation Dist	3.5mm
T <sub>2</sub>	Invalid Operation Dist	1.0mm
F <sub>1</sub>	Pressure for Valid Operation	3.5k <sub>g</sub>
F <sub>2</sub>	Pressure for Invalid Operation	

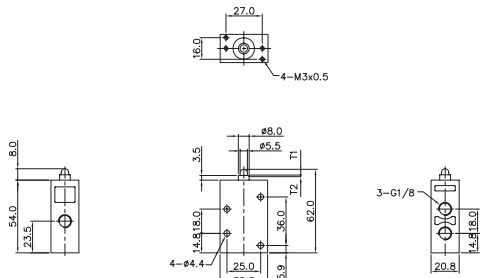

### 3/2-Way, Direct Pushrod Operation Thread-1/4

T <sub>1</sub>	Valid Operation Dist	3.5mm
T <sub>2</sub>	Invalid Operation Dist	1.0mm
F <sub>1</sub>	Pressure for Valid Operation	3.5k <sub>g</sub>
F <sub>2</sub>	Pressure for Invalid Operation	

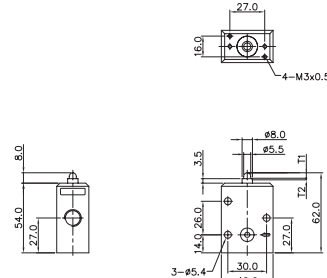

### 3/2-Way, Direct Roller Lever Operation Thread-1/8

		YMV310-1RP	YMV310-2RP
T <sub>1</sub>	Valid Operation Dist	8.5mm	9.0mm
T <sub>2</sub>	Invalid Operation Dist	3.0mm	3.5mm
F <sub>1</sub>	Pressure for Valid Operation	2.0k <sub>g</sub>	2.0k <sub>g</sub>
F <sub>2</sub>	Pressure for Invalid Operation		

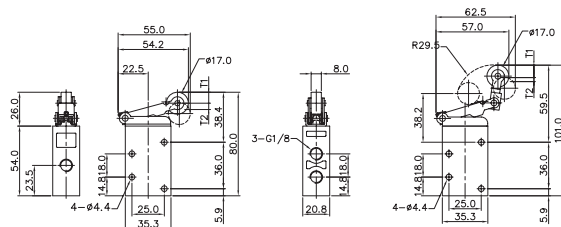
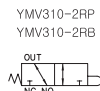
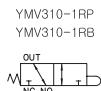

### 3/2-Way, Direct Roller Lever Operation Thread-1/4

		YMV410-1RP	YMV410-2RP
T <sub>1</sub>	Valid Operation Dist	8.0mm	9.0mm
T <sub>2</sub>	Invalid Operation Dist	3.0mm	3.5mm
F <sub>1</sub>	Pressure for Valid Operation	2.0k <sub>g</sub>	2.0k <sub>g</sub>
F <sub>2</sub>	Pressure for Invalid Operation		

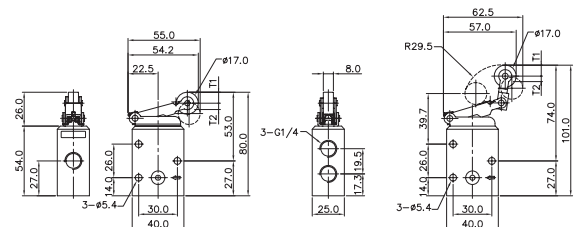
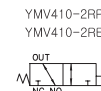
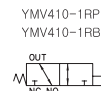

### 3/2-Way, Direct Pushrod & Selector Operation Thread-1/8

		YMV310-FP-3	YMV310-SL-3	YMV310-MS-3	YMV310-MT-3
T <sub>1</sub>	Valid Operation Dist	5.5mm			
T <sub>2</sub>	Invalid Operation Dist	1.0mm			
F <sub>1</sub>	Pressure for Valid Operation	3.5k <sub>g</sub>			
F <sub>2</sub>	Pressure for Invalid Operation				



Flush, Push Button      2-Position Selector      Dia Spring Return      Turn to unlock

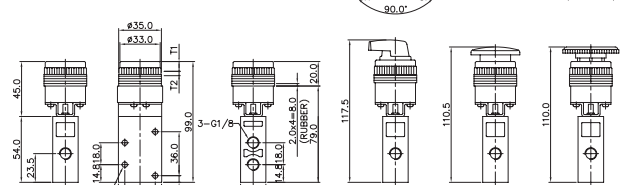
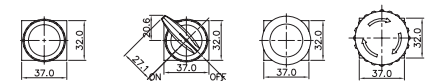

### 3/2-Way, Direct Pushrod & Selector Operation Thread-1/4

		YMV410-FP-3	YMV410-SL-3	YMV410-MS-3	YMV410-MT-3
T <sub>1</sub>	Valid Operation Dist	5.5mm			
T <sub>2</sub>	Invalid Operation Dist	1.0mm			
F <sub>1</sub>	Pressure for Valid Operation	3.5k <sub>g</sub>			
F <sub>2</sub>	Pressure for Invalid Operation				



Flush, Push Button      2-Position Selector      Dia Spring Return      Turn to unlock

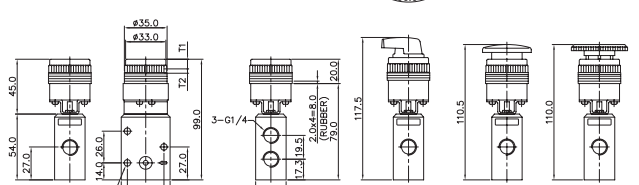
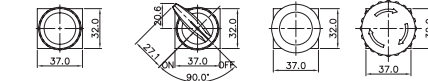

# PMEV Series

Panel Mounting Mechanically  
Actuated Spool Valves

- 5/2, 3/2 - M5, 1/8, 1/4
- A Wide Range of Option Available
- Direct Operation Type
- Simple Panel Mounting

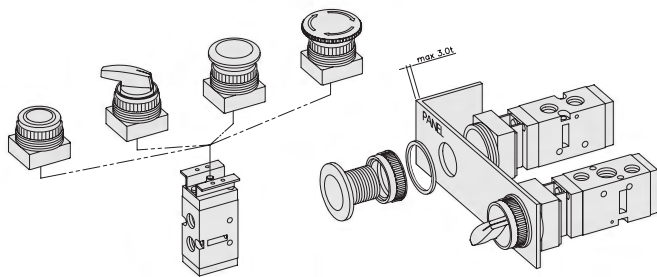
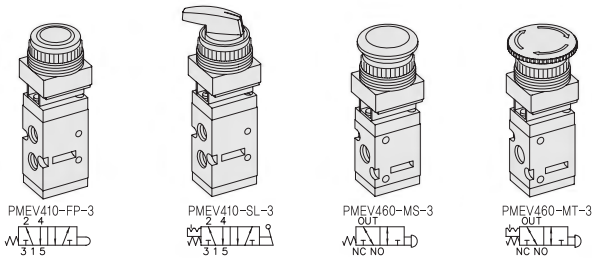
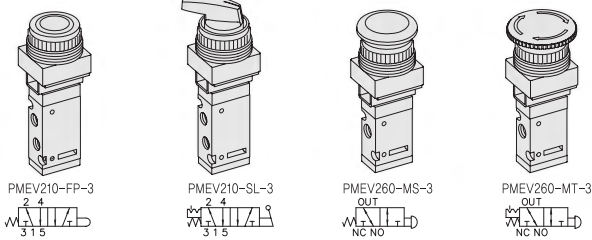
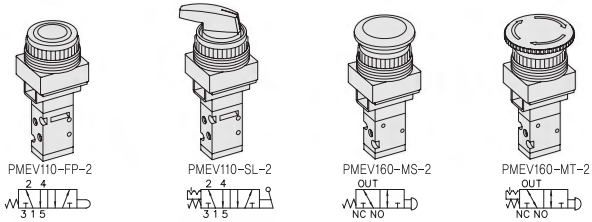

## SPECIFICATION

ITEM	SERIES	PMEV100	PMEV200	PMEV400
FUNCTION		5/2, 3/2-Way		
Fluids		Compressed Air & Inert Gases		
Port Size		M5	1/8	1/4
Pressure(bar)		0~8.0		
Eff. Sectional Area(mm <sup>2</sup> )-5bar		3.5	12.6	19.0
Ambient & Fluid Temp.		5~60°C (41~140°F)		
Lubrication		Not Required(Use ISO VG32#)		

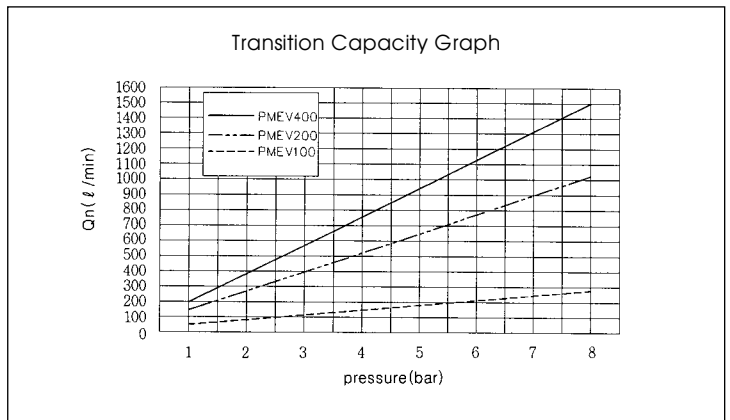

- ### The Material of Parts
- Valve Body : Die-Cast Aluminium
  - Spool : Aluminium
  - Seals : NBR
  - Spring : Stainless
  - Button Parts : Stainless Steel, POM
  - Switch Parts : Glass Filled Nylon, POM

\* The specification on each item can be amended without any prenotice to improve a performance.  
\* The specification on each item can be different from actual specification.

## ORDERING NO.

**PMEV1 1 0 - FP - 2**

Valve Series	Function	Port Size & Thread	Switch Type	Mounting Holes
PMEV1 : M5×0.8-Port Body	1 5/2 - Spring Return 6 3/2 - Spring Return	0 G 1 NPT	FP Flush, Push Button (R) SL 2-Position Selector (B) MS Mushroom 40mm dia Spring Return (R) MT Mushroom 40mm dia Turn to Unlock (R)	2 25mm 3 30mm
PMEV2 : 1/8-Port Body				
PMEV4 : 1/4-Port Body				

( ) Standard Color



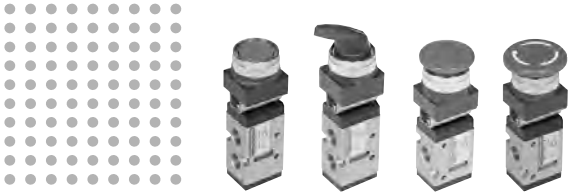

# Panel Mounting Mechanically Actuated Spool Valves **Port Thread M5, 1/8, 1/4**

## 5/2-Way, Pushrod & Selector Operation Thread-M5 × 0.8

OPERATION SPEC.	
T <sub>1</sub> Valid Operation Dist	5.5mm
T <sub>2</sub> Invalid Operation Dist	1.0mm
F <sub>1</sub> Pressure for Valid Operation	2.5kg
F <sub>2</sub> Pressure for Invalid Operation	

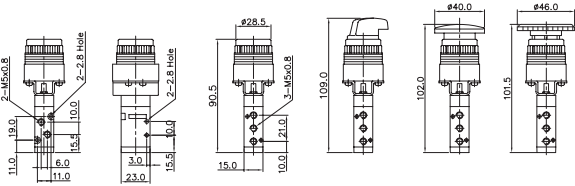
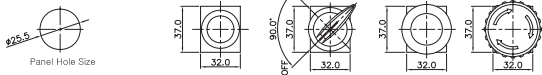
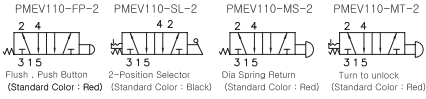

## 3/2-Way, Pushrod & Selector Operation Thread-M5 × 0.8

OPERATION SPEC.	
T <sub>1</sub> Valid Operation Dist	5.5mm
T <sub>2</sub> Invalid Operation Dist	1.0mm
F <sub>1</sub> Pressure for Valid Operation	2.5kg
F <sub>2</sub> Pressure for Invalid Operation	

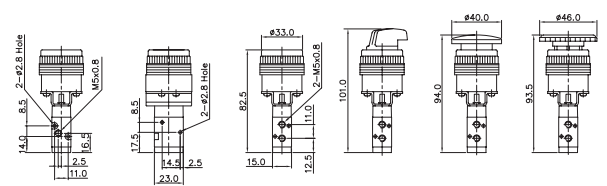
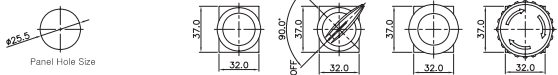
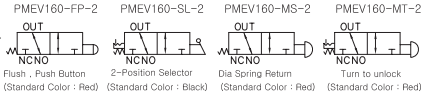

## 5/2-Way, Pushrod & Selector Operation Thread-1/8

OPERATION SPEC.	
T <sub>1</sub> Valid Operation Dist	5.5mm
T <sub>2</sub> Invalid Operation Dist	1.0mm
F <sub>1</sub> Pressure for Valid Operation	3.0kg
F <sub>2</sub> Pressure for Invalid Operation	

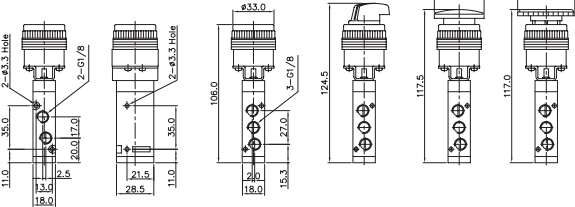
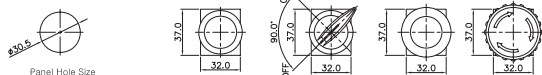
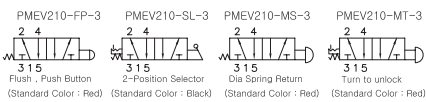

## 3/2-Way, Pushrod & Selector Operation Thread-1/8

OPERATION SPEC.	
T <sub>1</sub> Valid Operation Dist	5.5mm
T <sub>2</sub> Invalid Operation Dist	1.0mm
F <sub>1</sub> Pressure for Valid Operation	3.0kg
F <sub>2</sub> Pressure for Invalid Operation	

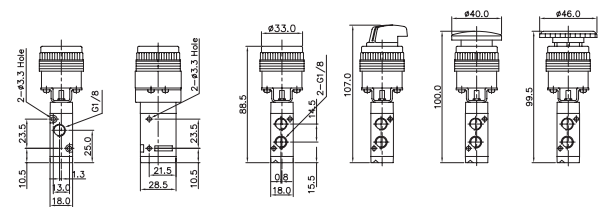
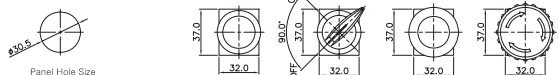
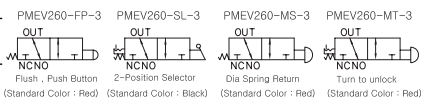

## 5/2-Way, Pushrod & Selector Operation Thread-1/4

OPERATION SPEC.	
T <sub>1</sub> Valid Operation Dist	5.5mm
T <sub>2</sub> Invalid Operation Dist	1.0mm
F <sub>1</sub> Pressure for Valid Operation	4.0kg
F <sub>2</sub> Pressure for Invalid Operation	

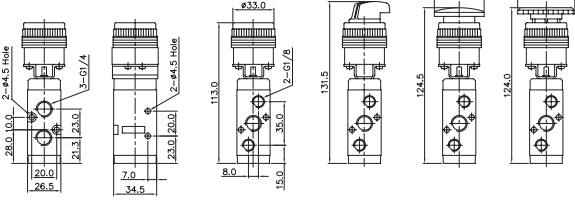
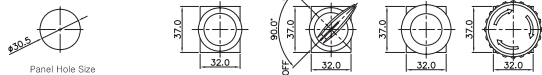
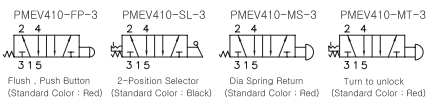

## 3/2-Way, Pushrod & Selector Operation Thread-1/4

OPERATION SPEC.	
T <sub>1</sub> Valid Operation Dist	5.5mm
T <sub>2</sub> Invalid Operation Dist	1.0mm
F <sub>1</sub> Pressure for Valid Operation	4.0kg
F <sub>2</sub> Pressure for Invalid Operation	

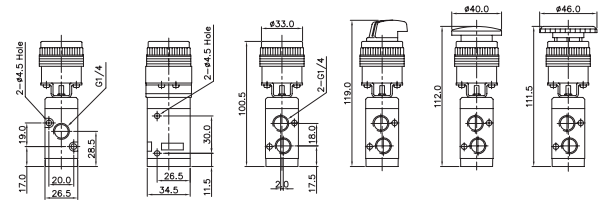
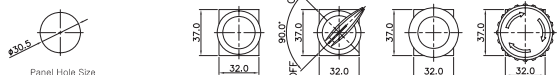
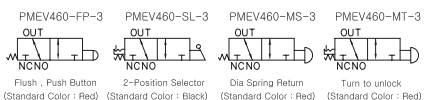

# RLV Series

Roller Lever Mechanically Actuated Spool Valves

- 5/2, 3/2 - M5, 1/8, 1/4
- Excellent Durability
- Convenient Installation
- Direct Type, Quick Response

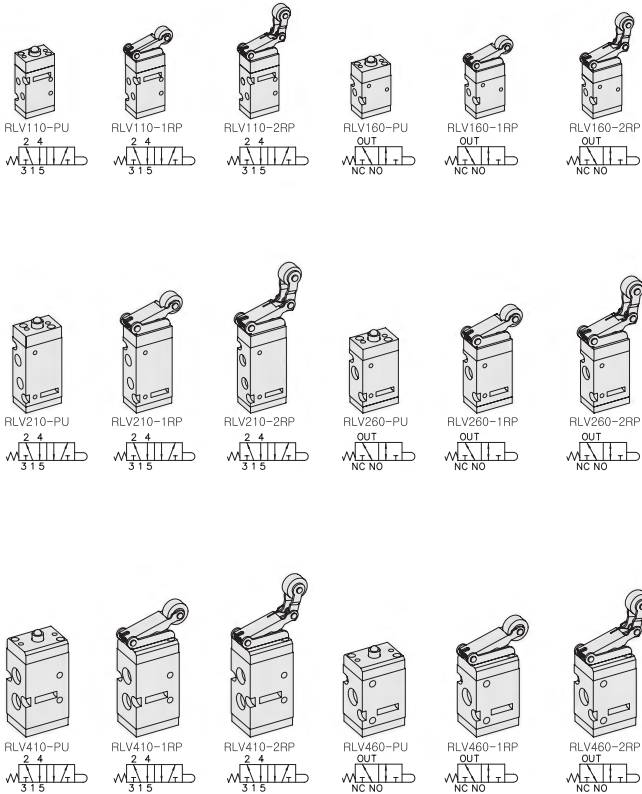

## SPECIFICATION

ITEM	SERIES	RLV100	RLV200	RLV400
FUNCTION		5/2, 3/2-Way		
Fluids		Compressed Air & Inert Gases		
Port Size		M5	1/8	1/4
Pressure(bar)		0~8.0		
Eff. Sectional Area(mm <sup>2</sup> )-5bar		3.5	12.6	19.0
Ambient & Fluid Temp.		5~60°C (41~140°F)		
Lubrication		Not Required(Use ISO VG32#)		

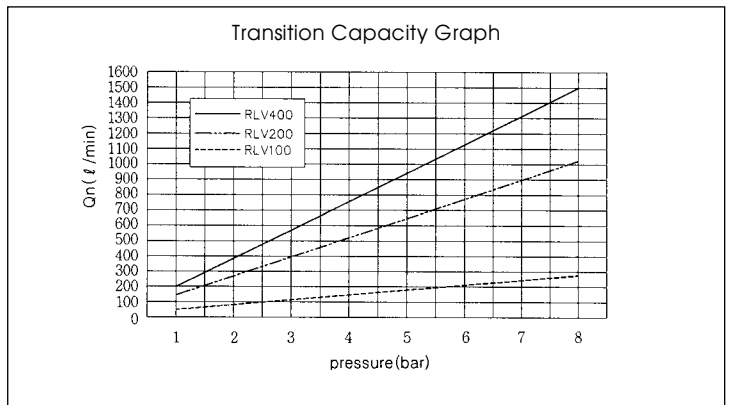

- ### The Material of Parts
- Valve Body : Die-Cast Aluminium
  - Lever Parts : Steel Plate, POM
  - Spool : Aluminium
  - Pilot Parts : Glass Filled Nylon
  - Seals : NBR
  - Cap : Zinc Pressure Die-Cast
  - Spring : Stainless
  - Button Parts : Stainless Steel

\* The specification on each item can be amended without any prenotice to improve a performance.  
 \* The specification on each item can be different from actual specification.

## ORDERING NO.

**RLV1 1 0 - PU**

Valve Series	Function	Port Size & Thread	Operator / Function
RLV1 : M5×0.8-Port Body	1 5/2 - Spring Return 6 3/2 - Spring Return	0 G 1 NPT	PU Pushrod 1RP Two-way Roller Plastic Lever 1RB Two-way Roller Bearing Lever 2RP One-way Roller Plastic Lever 2RB One-way Roller Bearing Lever
RLV2 : 1/8-Port Body			
RLV4 : 1/4-Port Body			

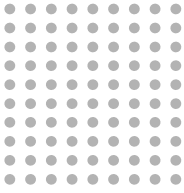

# Roller Lever Mechanically Actuated Spool Valves

# Port Thread M5, 1/8, 1/4

## 5/2-Way, Pushrod & Roller Lever Operation Thread-M5 × 0.8

	RLV110	RLV110-1RP	RLV110-2RP
T <sub>1</sub> Valid Operation Dist	2.0mm	6.0mm	7.0mm
T <sub>2</sub> Invalid Operation Dist	1.0mm	2.0mm	2.0mm
F <sub>1</sub> Pressure for Valid Operation	2.0kgf	1.0kgf	1.0kgf
F <sub>2</sub> Pressure for Invalid Operation			

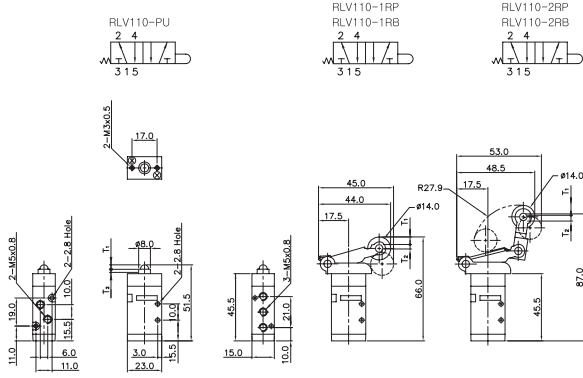

## 3/2-Way, Pushrod & Roller Lever Operation Thread-M5 × 0.8

	RLV160-PU	RLV160-1RP	RLV160-2RP
T <sub>1</sub> Valid Operation Dist	2.0mm	6.0mm	7.0mm
T <sub>2</sub> Invalid Operation Dist	1.0mm	2.0mm	2.0mm
F <sub>1</sub> Pressure for Valid Operation	2.0kgf	1.0kgf	1.0kgf
F <sub>2</sub> Pressure for Invalid Operation			

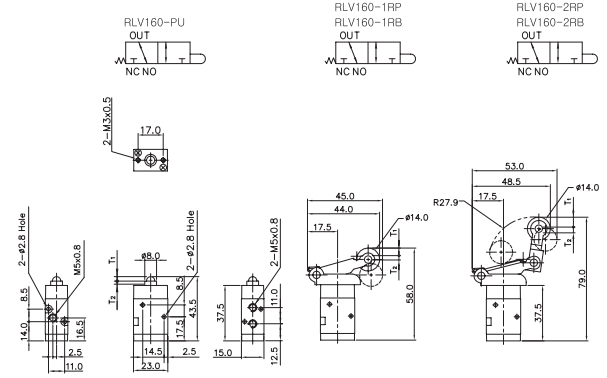

## 5/2-Way, Pushrod & Roller Lever Operation Thread-1/8

	RLV210	RLV210-1RP	RLV210-2RP
T <sub>1</sub> Valid Operation Dist	3.0mm	8.5mm	9.5mm
T <sub>2</sub> Invalid Operation Dist	1.0mm	2.0mm	2.0mm
F <sub>1</sub> Pressure for Valid Operation	2.5kgf	1.5kgf	1.5kgf
F <sub>2</sub> Pressure for Invalid Operation			

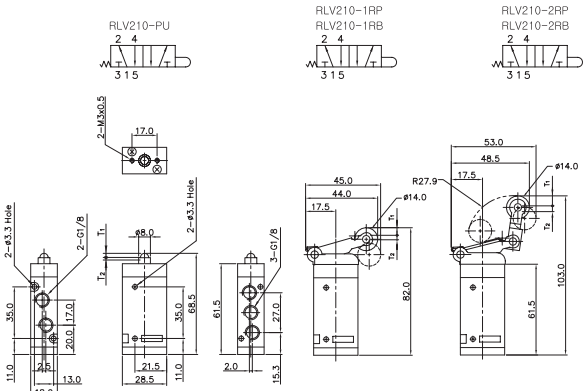

## 3/2-Way, Pushrod & Roller Lever Operation Thread-1/8

	RLV260-PU	RLV260-1RP	RLV260-2RP
T <sub>1</sub> Valid Operation Dist	3.0mm	8.5mm	9.5mm
T <sub>2</sub> Invalid Operation Dist	1.0mm	2.0mm	2.0mm
F <sub>1</sub> Pressure for Valid Operation	2.5kgf	1.5kgf	1.5kgf
F <sub>2</sub> Pressure for Invalid Operation			

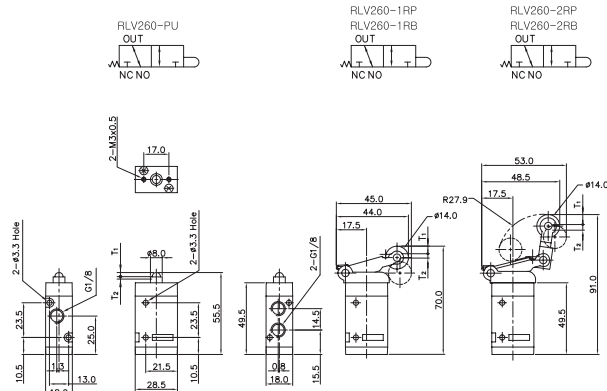

## 5/2-Way, Pushrod & Roller Lever Operation Thread-1/4

	RLV410	RLV410-1RP	RLV410-2RP
T <sub>1</sub> Valid Operation Dist	3.6mm	9.0mm	10.5mm
T <sub>2</sub> Invalid Operation Dist	1.0mm	3.0mm	3.0mm
F <sub>1</sub> Pressure for Valid Operation	3.5kgf	1.5kgf	1.5kgf
F <sub>2</sub> Pressure for Invalid Operation			

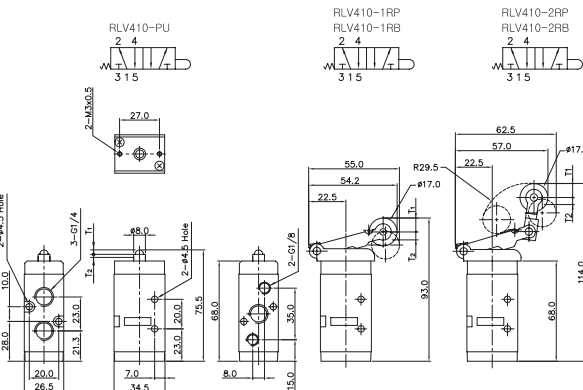

## 3/2-Way, Pushrod & Roller Lever Operation Thread-1/4

	RLV460-PU	RLV460-1RP	RLV460-2RP
T <sub>1</sub> Valid Operation Dist	3.6mm	9.0mm	10.5mm
T <sub>2</sub> Invalid Operation Dist	1.0mm	3.0mm	3.0mm
F <sub>1</sub> Pressure for Valid Operation	3.5kgf	1.5kgf	1.5kgf
F <sub>2</sub> Pressure for Invalid Operation			

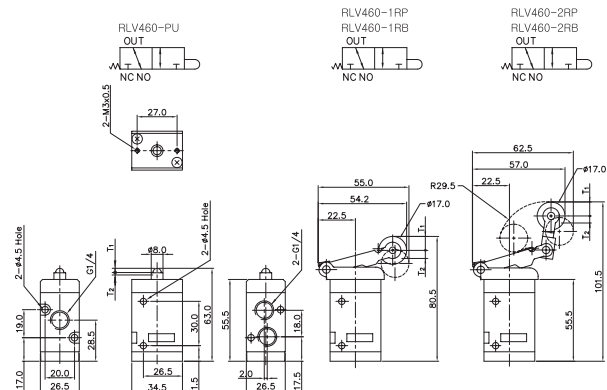

# HLV Series

Hand Lever Operated  
Spool Valves

- Direct Operation Type
- 5/2, 5/3, 3/2
- 1/8, 1/4, 3/8, 1/2
- High Flow Capacity

## SPECIFICATION

ITEM	SERIES	HLV300	HLV400	HLV500	HLV600
FUNCTION		5/2, 5/3-Way	5/2, 5/3, 3/2-Way	5/2, 5/3-Way	5/2, 5/3-Way
Fluids	Compressed Air & Inert Gases				
Port Size		1/8	1/4	3/8	1/2
Pressure(bar)	0~8.0				
Eff. Sectional Area(mm <sup>2</sup> )-5bar		13.5	18.0	35.0	90.0
Ambient & Fluid Temp.	5~60°C (41~140°F)				
Lubrication	Not Required(Use ISO VG32#)				

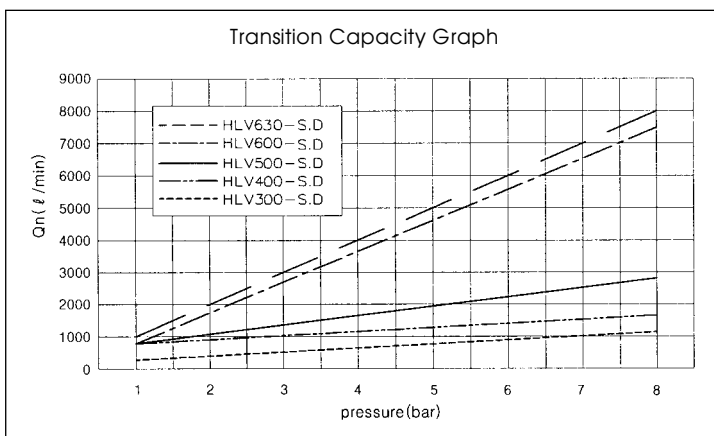

The Material of Parts

- Valve Body : Die-Cast Aluminium
- Cap : Zinc Pressure Die-Cast
- Spool : Aluminium
- Seals : NBR
- Spring : Stainless
- Lever Parts : Steel, NBR, Plastic

\* The specification on each item can be amended without any prenotice to improve a performance.  
\* The specification on each item can be different from actual specification.

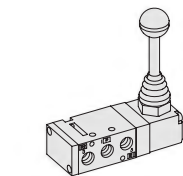

HLV310-S Single Detented

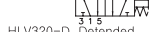

HLV320-D Detented

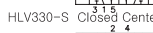

HLV330-S Closed Center

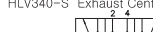

HLV340-S Exhaust Center



HLV350-S Pressure Center



HLV330-D Closed Center

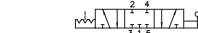

HLV340-D Exhaust Center



HLV350-D Pressure Center

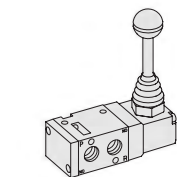

HLV460-S Single OUT

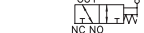

HLV460-D Detented OUT

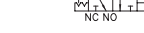

HLV410-S Single

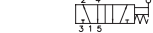

HLV420-D Detented



HLV430-S Closed Center

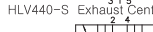

HLV440-S Exhaust Center



HLV450-S Pressure Center



HLV430-D Closed Center

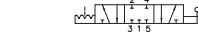

HLV440-D Exhaust Center

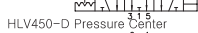

HLV450-D Pressure Center

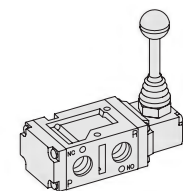

HLV560-S Single OUT

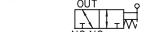

HLV560-D Detented OUT

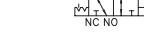

HLV510-S Single

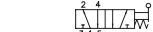

HLV520-D Detented



HLV530-S Closed Center

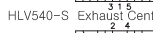

HLV540-S Exhaust Center

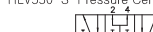

HLV550-S Pressure Center



HLV530-D Closed Center

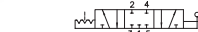

HLV540-D Exhaust Center



HLV550-D Pressure Center

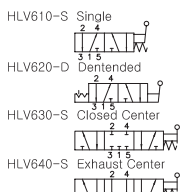
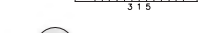

HLV610-S Single



HLV620-D Detented



HLV630-S Closed Center



HLV640-S Exhaust Center



HLV650-S Pressure Center

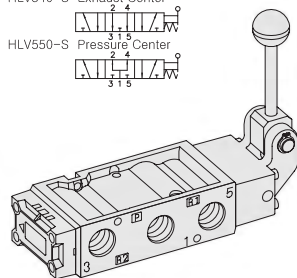

HLV630-D Closed Center



HLV640-D Exhaust Center



HLV650-D Pressure Center



## ORDERING NO.

HLV3 1 0 - S

Valve Series

HLV3 :  
1/8-Port Body  
HLV4 :  
1/4-Port Body  
HLV5 :  
3/8-Port Body  
HLV6 :  
1/2-Port Body

Function

1	5/2 Single
2	5/2 Double
3	5/3 Closed Center
4	5/3 Open Center
5	5/3 Pressure Center
6	3/2 Normally Closed

Port Size & Thread

0	G
1	NPT

Return Method

S	Single Spring Return
D	Double Detented

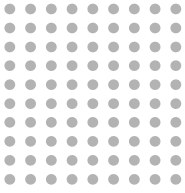

# Hand Lever Operated Spool Valves

# Port Thread 1/8, 1/4, 3/8, 1/2

## 5/2-Way, Hand Lever Manually Actuated Valve Thread-G1/8

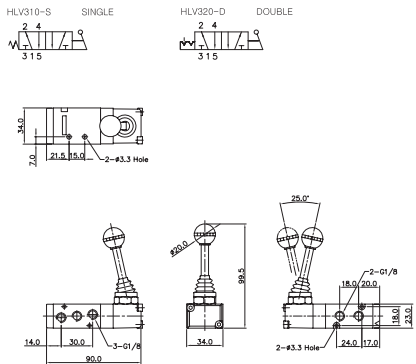

## 5/3-Way, Hand Lever Manually Actuated Valve Thread-G1/8

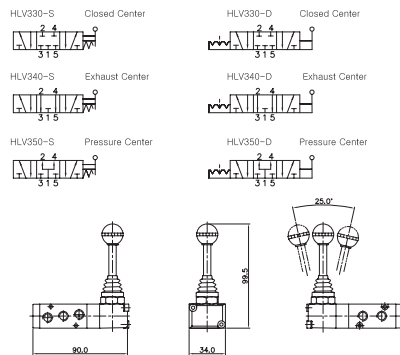

## 5/2-Way, Hand Lever Manually Actuated Valve Thread-G1/4

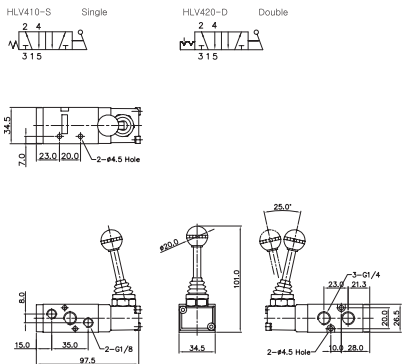

## 5/3-Way, Hand Lever Manually Actuated Valve Thread-G1/4

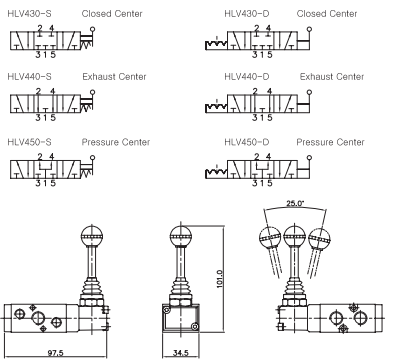

## 3/2-Way, Hand Lever Manually Actuated Valve Thread-G1/4

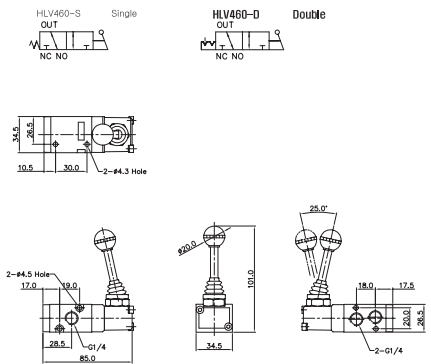

## 5/2-Way, Hand Lever Manually Actuated Valve Thread-G3/8

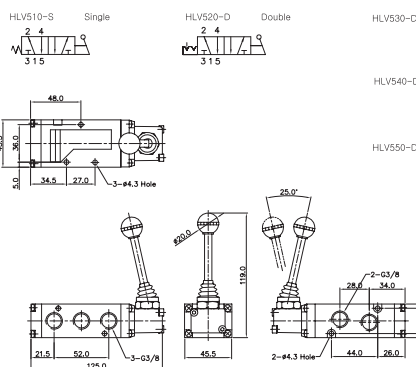

## 5/3-Way, Hand Lever Manually Actuated Valve Thread-G3/8

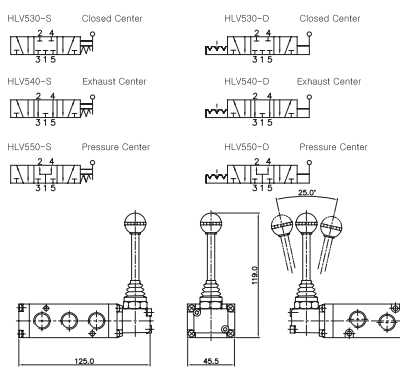

## 3/2-Way, Hand Lever Manually Actuated Valve Thread-G3/8

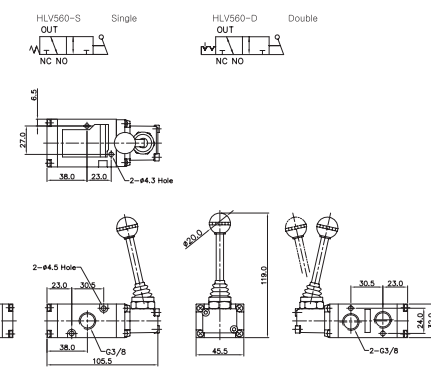

## 5/2-Way, Hand Lever Manually Actuated Valve Thread-G1/2

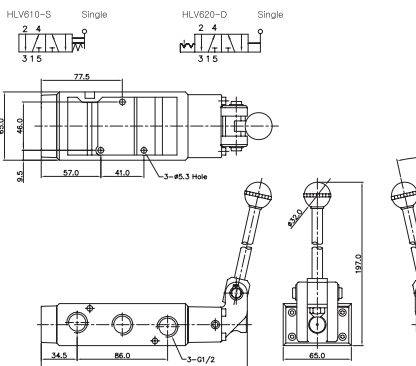

## 5/3-Way, Hand Lever Manually Actuated Valve Thread-G1/2

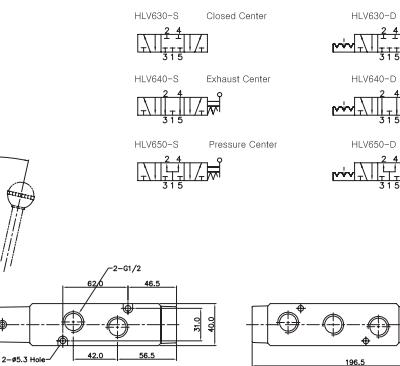

# KMV Series

Knob Push / Pull Manually  
Actuated Spool Valves

- 5/2, 3/2 - 1/8, 1/4
- Direct Operation Type
- Simple Operation
- Space Economy Type

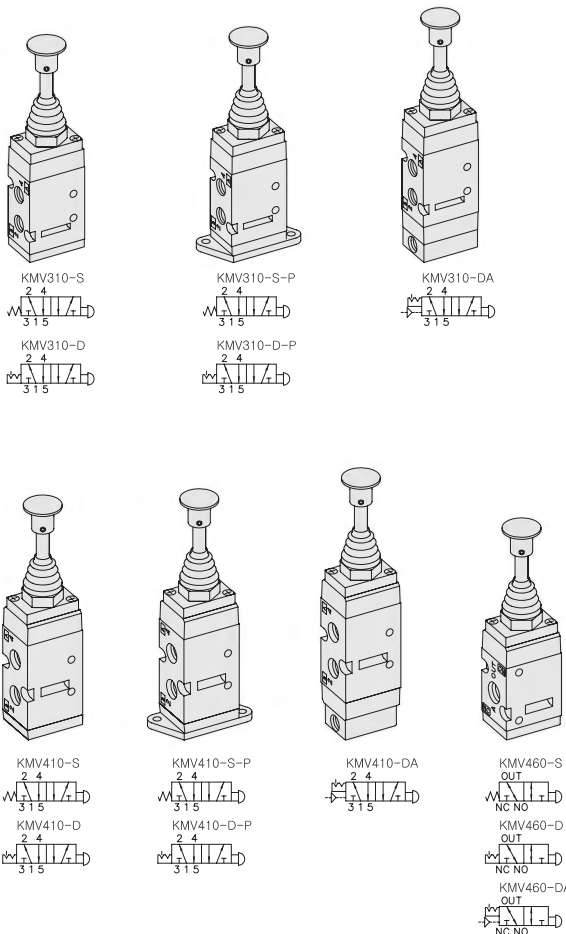

## SPECIFICATION

ITEM	SERIES	KMV300	KMV400
	FUNCTION	5/2-Way	5/2, 3/2-Way
Fluids	Compressed Air & Inert Gases		
Port Size	1/8		1/4
Pressure(bar)	0~8.0		
Eff. Sectional Area(mm <sup>2</sup> )-5bar	13.5		18.0
Ambient & Fluid Temp.	5~60°C (41~140°F)		
Lubrication	Not Required(Use ISO VG32#)		

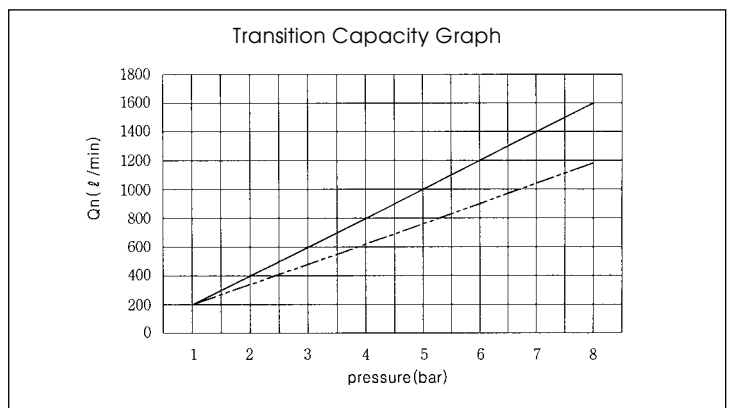

- ### The Material of Parts
- Valve Body : Die-Cast Aluminium
  - Cap : Zinc Pressure Die-Cast
  - Spool : Aluminium
  - Seals : NBR
  - Spring : Stainless
  - Lever Parts : Steel, NBR, Aluminium
  - Standing Plate : Steel Plate

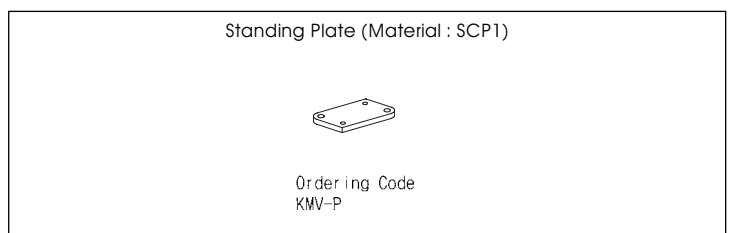

※ The specification on each item can be amended without any prenotice to improve a performance.  
※ The specification on each item can be different from actual specification.

## ORDERING NO.

KMV3 1 0 - S - P

Valve Series	Function	Port Size & Thread	Return Method	Plate
KMV3 : 1/8-Port Body	1   5/2 Single 6   3/2 Normally Closed	0   G 1   NPT	S   Push, Spring Return D   Push, Full DA   Push, Air Return	P   Standing Plate
KMV4 : 1/4-Port Body				



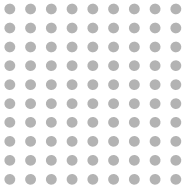

# Knob Push / Pull Manually Actuated Valves

## Port Thread 1/8, 1/4

### 5/2-Way, Spring Return & Push Pull & Air Return Operation Thread-G1/8

ITEM	KMV310-S	KMV310-D
T <sub>1</sub>	4.0mm	4.0mm
F <sub>1</sub>	4.5kg	2.0kg

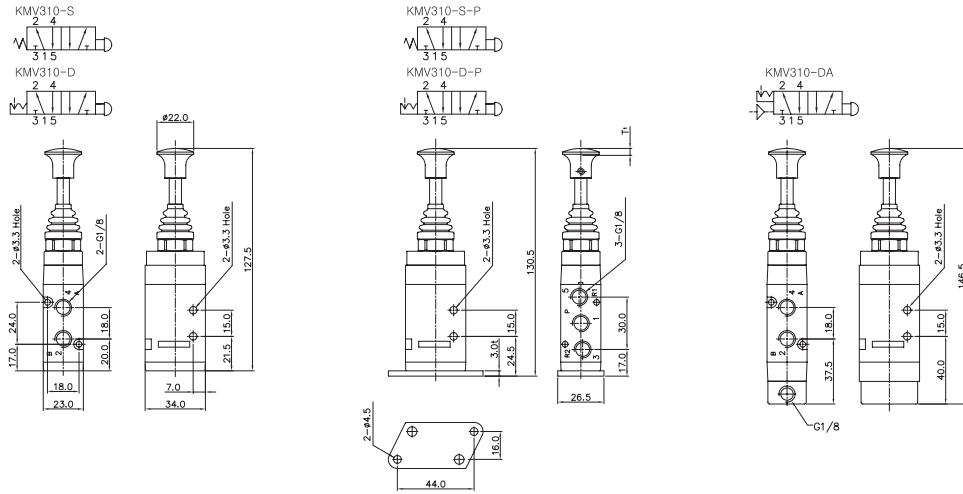

### 5/2-Way, Spring Return & Push Pull & Air Return Operation Thread-G1/4

ITEM	KMV410-S	KMV420-D
T <sub>1</sub>	4.0mm	4.0mm
F <sub>1</sub>	4.5kg	2.0kg

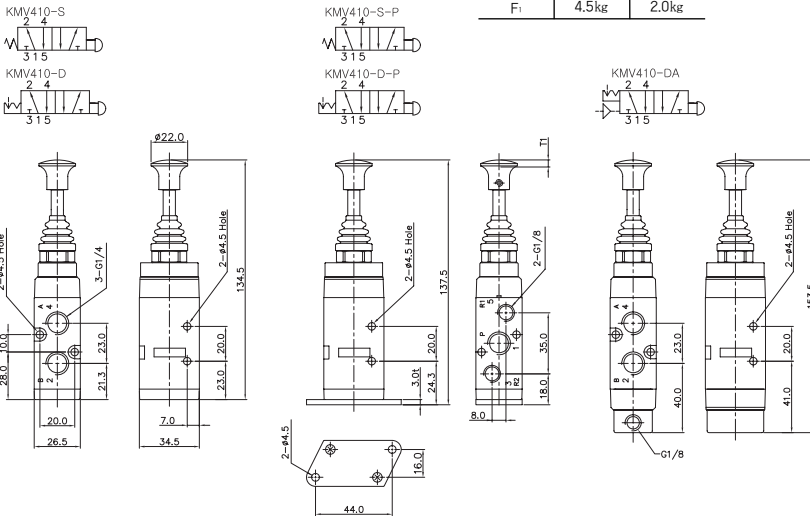

### 3/2-Way, Spring Return & Push Pull & Air Return Operation Thread-G1/4

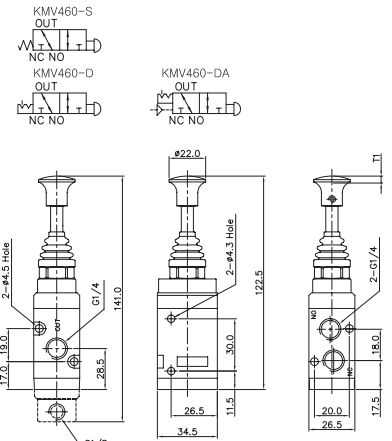

# TMV Series

Toggle Lever operated Mechanically Actuated Spool Valves

- 5/2, 3/2 - 1/8, 1/4
- Direct Operation Type
- Simple Operation
- Manifold Mounting Type

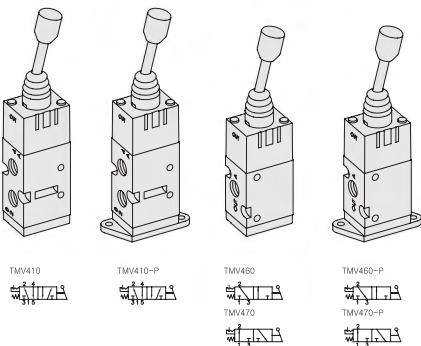
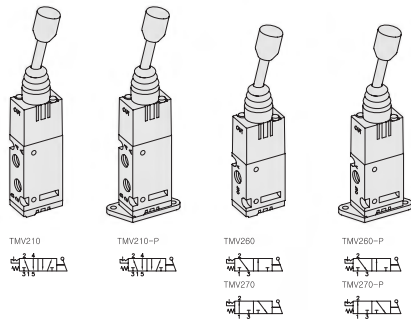

## SPECIFICATION

ITEM	SERIES	TMV200	TMV400
	FUNCTION	5/2, 3/2-Way	
Fluids	Compressed Air & Inert Gases		
Port Size		1/8	1/4
Pressure(bar)		2.0~10.0	0~8.0
Eff. Sectional Area(mm <sup>2</sup> )-5bar		9.0	18.0
Ambient & Fluid Temp.	5~60°C (41~140°F)		
Lubrication	Not Required(Use ISO VG32#)		

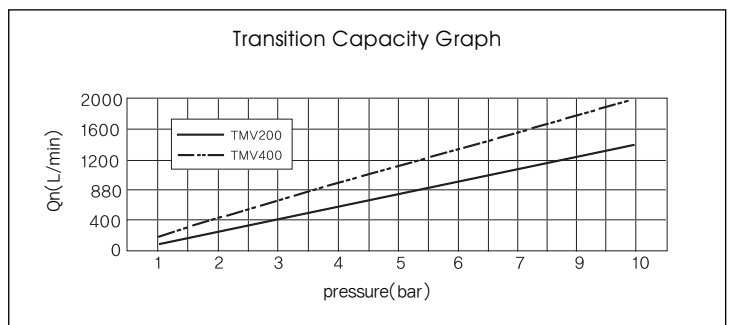

- ### The Material of Parts
- Valve Body : Die-Cast Aluminium
  - Cap : Zinc Pressure Die-Cast
  - Spool : Aluminium
  - Seals : NBR
  - Spring : Stainless
  - Lever Parts : Steel, NBR, Aluminium

Standing Plate (Material : SCP1)

Ordering Code  
TMV-P

\* The specification on each item can be amended without any prenotice to improve a performance.  
\* The specification on each item can be different from actual specification.

## ORDERING NO.

**TMV2 1 - 0 - P**

Valve Series	Function	Port Size & Thread	Plate
TMV2 : 1/8-Port Body	1   5/2 Single 6   3/2 Normally Closed 7   3/2 Normally Open	0   G 1   NPT	P   Standing Plate
TMV4 : 1/4-Port Body			



# FT Series

Foot Treadle Operated  
Air Return & Spring Return Spool Valves

- 5/2, 5/3
- Pilot Type - 1/4, 3/8
- Direct Operation Type - 1/2
- Excellent Durability

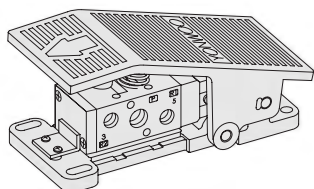

FT410-S  
2 4  
3 1 5

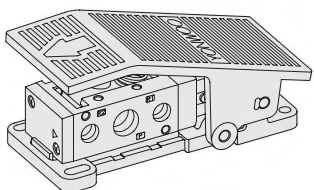

FT510-S  
2 4  
3 1 5

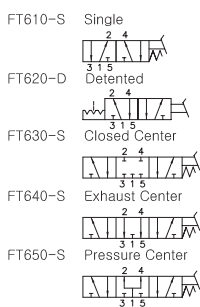
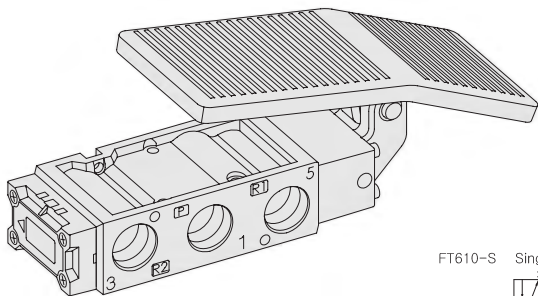

## SPECIFICATION

ITEM	SERIES	FT410-S	FT510-S	FT600-S, D
	FUNCTION	5/2-Way		5/2, 5/3-Way
Fluids	Compressed Air & Inert Gases			
Port Size		1/4	3/8	1/2
Pressure(bar)		1.5~8.0		0~8.0
Eff. Sectional Area(mm <sup>2</sup> )-5bar		19.0	35.0	90.0
Ambient & Fluid Temp.	5~60°C (41~140°F)			
Lubrication	Not Required(Use ISO VG32#)			

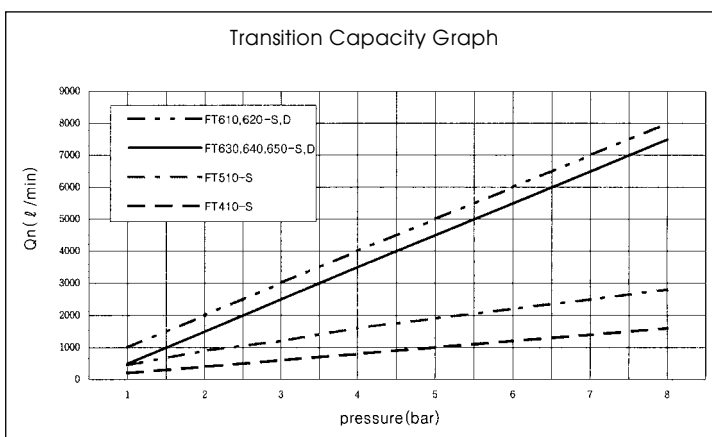

## The Material of Parts

- Valve Body : Die-Cast Aluminium
- Spool : Aluminium
- Seals : NBR
- Spring : Stainless
- Cap : Zinc Pressure Die-Cast
- Pilot parts : Glass Filled Nylon
- Foot Upper Plate : Die-Cast Aluminium
- Foot Low Plate : Zinc Pressure Die-Cast

\* The specification on each item can be amended without any prenotice to improve a performance.  
\* The specification on each item can be different from actual specification.

## ORDERING NO.

**FT4 1 0 - S**

Valve Series
FT4 : 1/4-Port Body
FT5 : 3/8-Port Body
FT6 : 1/2-Port Body

Function
1 5/2 Single
2 5/2 Double
3 5/3 Closed Center
4 5/3 Open Center
5 5/3 Pressure Center

Port Size & Thread
0 G
1 NPT

Return Method
S Spring Return
D Detented

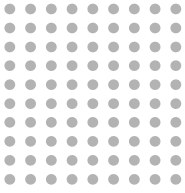

# Foot Treadle Operated Spool Valves

## Port Thread 1/4, 3/8, 1/2

### 5/2-Way, Foot Valve, Air Return Operation Thread-G1/4

FT410-S

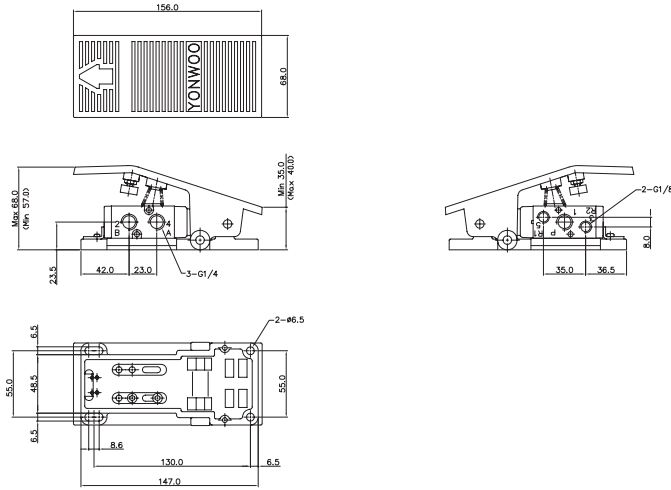
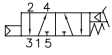

### 5/2-Way, Foot Valve, Air Return Operation Thread-G3/8

FT510-S

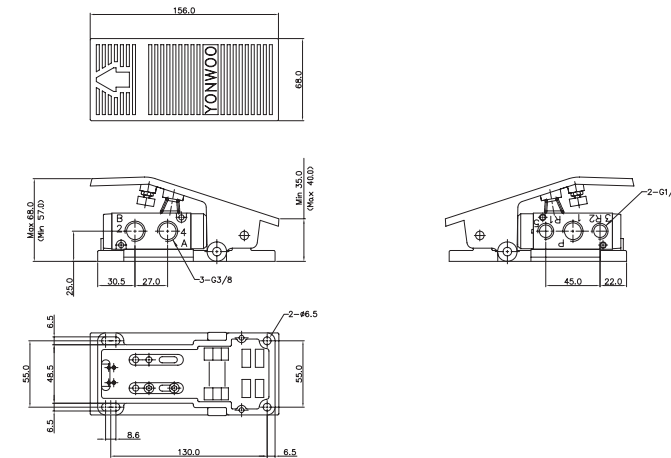
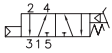

### 5/2-Way, Foot Valve, Spring Return & Detented Operation Thread-G1/2

FT610-S



FT620-D

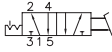

FT630-S

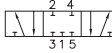

FT640-S

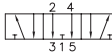

FT650-S

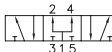

FT630-D



FT640-D



FT650-D

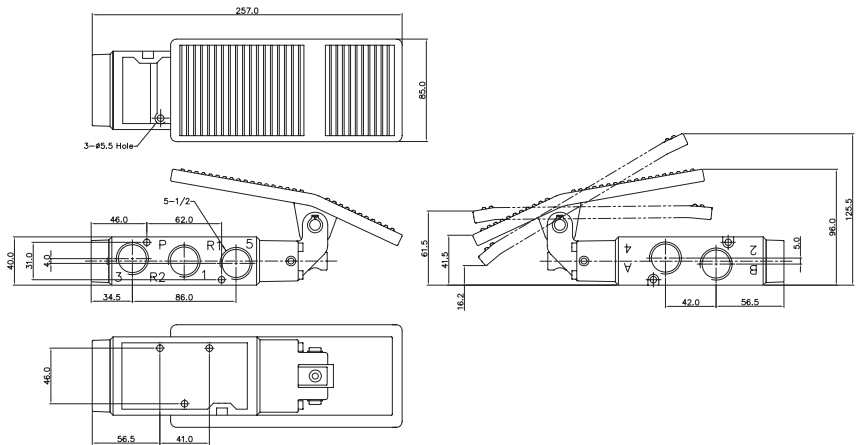
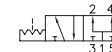





**COMPACT CYLINDER** Series  
**SPEED CONTROLLER** Series  
**AIR SILENCER** Series  
**AIR HYDRO CONVERTER** Series  
**BOOSTER CYLINDER** Series

**CHAPTER 10**



Compact Cylinder



Speed Controller



Metal Silencer



Plastic Silencer



Air Hydro Converter



Direct Compressed Type  
Booster Cylinder



Precompressed Type  
Booster Cylinder

# YC(D)Q2 Series

Compact Cylinder

- In Magnet, Without Magnet
- Female(Standard), Male Thread

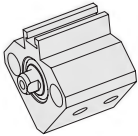

YCQ2B-12x5D~YCQ2B-12x30D  
YCDQ2B-12x5D~YCDQ2B-12x30D  
(ø12, ø16, ø20, ø25)

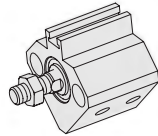

YCQ2B-12x5DM~YCQ2B-12x30DM  
YCDQ2B-12x5DM~YCDQ2B-12x30DM  
(ø12, ø16, ø20, ø25)

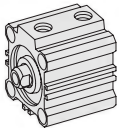

YCQ2B-32x5D~YCQ2B-32x50D  
YCDQ2B-32x5D~YCDQ2B-32x50D  
(ø32, ø40)

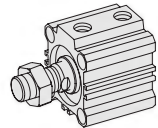

YCQ2B-32x5DM~YCQ2B-32x50DM  
YCDQ2B-32x5DM~YCDQ2B-32x50DM  
(ø32, ø40)

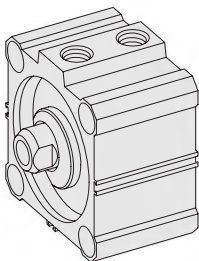

YCQ2B-50x10D~YCQ2B-50x50D  
YCDQ2B-50x10D~YCDQ2B-50x50D  
(ø50, ø63, ø80)

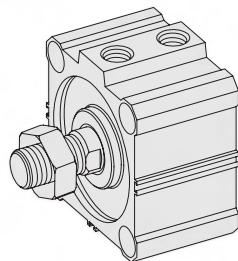

YCQ2B-50x10DM~YCQ2B-50x50DM  
YCDQ2B-50x10DM~YCDQ2B-50x50DM  
(ø50, ø63, ø80)

## SPECIFICATION

Fluids	Air
Certified Pressure	15bar
Maximum Operation Pressure	10bar
Minimum Operation Pressure	0.5bar (ø12, ø16 : 0.7bar)
Ambient & Fluid Temp.	5~60°C (41~140°F)
Lubrication	Not Required(Use ISO VG32#)
Cussion	None
Rod End Screw	Female Nut(standard), male Nut(option)
Tolerance of Screw	2nd grade of KS
Allowance of Stroke Distance	+1
Supporting Type	Standard
Mounting	Pierce(Basic), Both Ends Tap(Option)

### The Material of Parts

- Tube : Aluminium Extruding
- Piston : Aluminium
- Piston Rod : ø12~ø25-ST304  
ø32~ø80-Carbon Iron
- Seals : NBR
- Snap Ring : HSWR1
- Hex Nut : Carbon Iron
- Bush : DU Bush
- Head Cover : Aluminium
- Magnet : Rubber Magnet

\* The specification on each item can be amended without any prenotice to improve a performance.  
\* The specification on each item can be different from actual specification.

## ORDERING NO.

YCDQ2 **B** - **20** × **30** **D** **M**

Magnet is Attached or Not		Mounting		Tube Diameter	Cylinder Stroke			Operating Method		Rod Type	
YCQ2	Non Built-in	A	Both Ends Tap	12 : 12mm	Cylinder diameter	Cylinder Stroke(mm)		D	Double-acting type	Non-marked	Nut(Basic)
YCDQ2	Built-in	B	Pierce	16 : 16mm	ø12, ø16	5, 10, 15, 20, 25, 30				M5×0.8	M
				20 : 20mm	ø20, ø25	5, 10, 15, 20, 25, 30, 35, 40, 45, 50					
				25 : 25mm	ø32, ø40	5, 10, 15, 20, 25, 30, 35, 40, 45, 50, 75, 100					
				32 : 32mm	ø50, ø63	10, 15, 20, 25, 30, 35, 40, 45, 50, 75, 100					
				40 : 40mm	ø80	10, 15, 20, 25, 30, 35, 40, 45, 50, 75, 100					
				50 : 50mm							
				63 : 63mm							
				80 : 80mm							

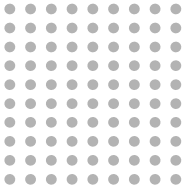

# YC(D)Q2 Series

## Non Built-in Magnet Dimension YCD2B-00 × 00D(M) φ12, φ16, φ20, φ25

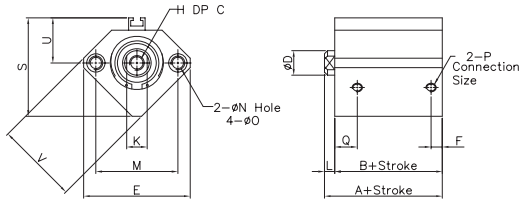

## Non Built-in Magnet Dimension YCD2B-00 × 00D(M) φ32, φ40, φ50, φ63, φ80

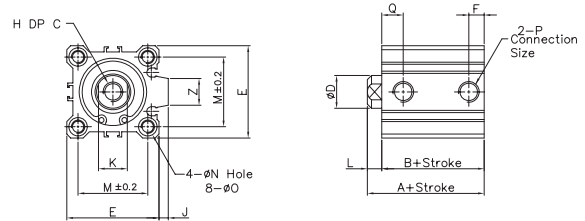

### Outside Dimension

Bore Size(mm)	Stroke Range(mm)	A	B	φD	E	F	H	C	φI	J	K	L	M	φN	φO	P	Q	S	U	V	Z	'B'	'C'	'E'	'G'	'H'	'L'	'X'
YCDQ2-12	5~30	20.5	17.0	6	32.0	5.0	M3×0.5	6	-	-	5	3.5	22	3.5	6.5 DP 3.5	M5×0.8	10.5	-	-	25	-	8	9.0	9.2	4	M5×0.8	14.0	10.5
YCDQ2-16	5~30	22.0	18.5	8	38.0	5.5	M4×0.7	8	-	-	6	3.5	28	3.5	6.5 DP 3.6	M5×0.8	10.0	-	-	29	-	10	10.0	9.2	5	M6×1.0	15.5	12.0
YCDQ2-20	5~50	24.0	19.5	10	46.8	5.5	M5×0.8	7	-	-	8	4.5	36	5.5	9.0 DP 7.0	M5×0.8	10.5	-	-	36	-	13	12.0	15.0	5	M8×1.25	18.5	14.0
YCDQ2-25	5~50	27.5	22.5	12	52.0	5.5	M6×1.0	12	-	-	10	5.0	40	5.5	9.0 DP 7.0	M5×0.8	11.0	-	-	40	-	17	15.0	19.6	6	M10×1.25	22.5	17.5
YCDQ2-32	5~100	30.0	23.0	16	45.0	7.5	M8×1.25	13	60	4.5	14	7.0	34	5.5	9.0 DP 7.0	G1/8	10.5	49.5	-	-	18	22	20.5	25.4	8	M14×1.5	28.5	23.5
YCDQ2-40	5~100	36.5	29.5	16	52.0	8.0	M8×1.25	13	69	5.0	14	7.0	40	5.5	9.0 DP 7.0	G1/8	12.0	57.0	-	-	18	22	20.5	25.4	8	M14×1.5	28.5	23.5
YCDQ2-50	10~100	38.5	30.5	20	64.0	10.5	M10×1.5	15	86	7.0	17	8.0	50	6.6	11.0 DP 8.0	G1/4	11.5	71.0	-	-	22	27	26.0	31.5	11	M18×1.5	33.5	28.5
YCDQ2-63	10~100	44.0	36.0	20	77.0	10.5	M10×1.5	15	103	7.0	17	8.0	60	9.0	14.0 DP 10.5	G1/4	15.0	84.0	-	-	22	27	26.0	31.2	11	M18×1.5	33.5	28.5
YCDQ2-80	10~100	53.0	43.5	25	98.0	12.5	M16×2.0	21	132	6.0	22	10.0	77	11.0	17.5 DP 13.5	G3/8	16.0	104.0	-	-	26	32	32.5	37.0	13	M22×1.5	43.5	35.5

## Built-in Magnet Dimension YCD2B-00 × 00D(M) φ12, φ16, φ20, φ25

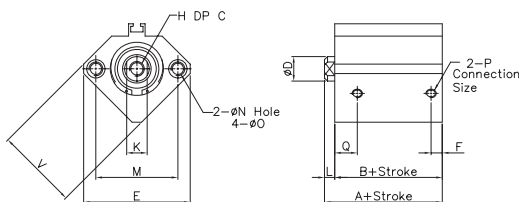

## Built-in Magnet Dimension YCD2B-00 × 00D(M) φ32, φ40, φ50, φ63, φ80

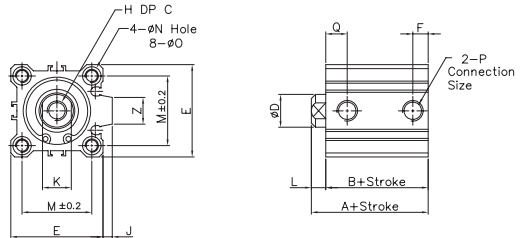

### Outside Dimension

Bore Size(mm)	Stroke Range(mm)	A	B	φD	E	F	H	C	φI	J	K	L	M	φN	φO	P	Q	S	U	V	Z	'B'	'C'	'E'	'G'	'H'	'L'	'X'
YCDQ2-12	5~30	31.5	28.0	6	32.0	5.0	M3×0.5	6	-	-	5	3.5	22	3.5	6.5 DP 3.5	M5×0.8	10.5	35.5	19.5	25	-	8	9.0	9.2	4	M5×0.8	14.0	10.5
YCDQ2-16	5~30	34.0	30.0	8	38.0	5.5	M4×0.7	8	-	-	6	3.5	28	3.5	6.5 DP 3.6	M5×0.8	10.0	41.5	22.5	29	-	10	10.0	9.2	5	M6×1.0	15.5	12.0
YCDQ2-20	5~50	36.0	31.5	10	46.8	5.5	M5×0.8	7	-	-	8	4.5	36	5.5	9.0 DP 7.0	M5×0.8	10.5	48.0	24.5	36	-	13	12.0	15.0	5	M8×1.25	18.5	14.0
YCDQ2-25	5~50	37.5	32.5	12	52.0	5.5	M6×1.0	12	-	-	10	5.0	40	5.5	9.0 DP 7.0	M5×0.8	11.0	53.5	27.5	40	-	17	15.0	19.6	6	M10×1.25	22.5	17.5
YCDQ2-32	5~100	40.0	33.0	16	45.0	7.5	M8×1.25	13	60	4.5	14	7.0	34	5.5	9.0 DP 7.0	G1/8	10.5	58.5	31.5	-	18	22	20.5	25.4	8	M14×1.5	28.5	23.5
YCDQ2-40	5~100	46.5	39.5	16	52.0	8.0	M8×1.25	13	69	5.0	14	7.0	40	5.5	9.0 DP 7.0	G1/8	12.0	66.0	35.0	-	18	22	20.5	25.4	8	M14×1.5	28.5	23.5
YCDQ2-50	10~100	48.5	40.5	20	64.0	10.5	M10×1.5	15	86	7.0	17	8.0	50	6.6	11.0 DP 8.0	G1/4	11.5	80.0	41.0	-	22	27	26.0	31.5	11	M18×1.5	33.5	28.5
YCDQ2-63	10~100	54.0	46.0	20	77.0	10.5	M10×1.5	15	103	7.0	17	8.0	60	9.0	14.0 DP 10.5	G1/4	15.0	93.0	47.5	-	22	27	26.0	31.2	11	M18×1.5	33.5	28.5
YCDQ2-80	10~100	63.5	53.5	25	98.0	12.5	M16×2.5	21	132	6.0	22	10.0	77	11.0	17.5 DP 13.5	G3/8	16.0	112.5	57.5	-	26	32	32.5	37.0	13	M22×1.5	43.5	35.5

## Male Screw Outside Dimension

φ12, φ16, φ20, φ25

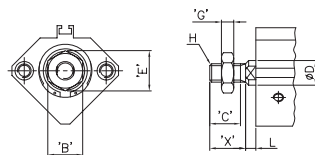

φ32, φ40, φ50, φ63, φ80

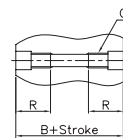
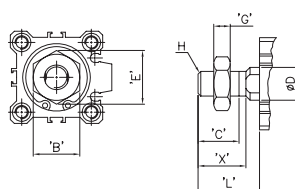

Both Ends Type

### Both Ends Tap Dimension

Bore Size	O	R
12	M4×0.7	10
16	M4×0.7	10
25	M6×1.0	17
30	M6×1.0	17
32	M6×1.0	17
40	M6×1.0	17
50	M8×1.25	20
63	M10×1.5	20
80	M12×1.75	25

# YSC Series

Speed Controller

- 1/8, 1/4
- Precise Flow Adjustment
- Elegant External View

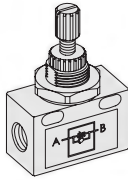

YSC02-1

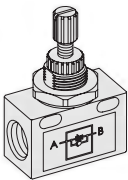

YSC02-2

## SPECIFICATION

ITEM	SERIES	
	YSC02	
	PORT SIZE	
	1/8	1/4
Inside Pressure(bar)	15.0	
Pressure Range(bar)	0.5~9.9	
Ambient & Fluid Temp.	5~60°C (41~140°F)	
Rotation Frequency	8 Cycle	
Weight(g)	80	
Free	Flux(Nl/min)	340
Flowing	Effective Profile Area mm <sup>2</sup>	5
Control	Flux(Nl/min)	250
Flowing	Effective Profile Area mm <sup>2</sup>	3.7
Applicable Syylinder Diameter( ∅ )	12, 16, 20, 25, 32, 40, 50, 63, 80	

### The Material of Parts

- Valve Body : Zinc Pressure Die-Cast
- Lock Nut : Brass
- Housing : Brass
- Controll Bar : Brass
- Hex Nut : Carbon Iron
- Seals : NBR

\* The specification on each item can be amended without any prenotice to improve a performance.  
 \* The specification on each item can be different from actual specification.

## ORDERING NO.

**YSC 02 - 1**

Model

YSC 02

Port Size & Thread

1	G 1/8
2	G 1/4
3	NPT 1/8
4	NPT 1/4

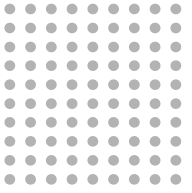

Pipe Type Speed Controller  
Thread- 1/8

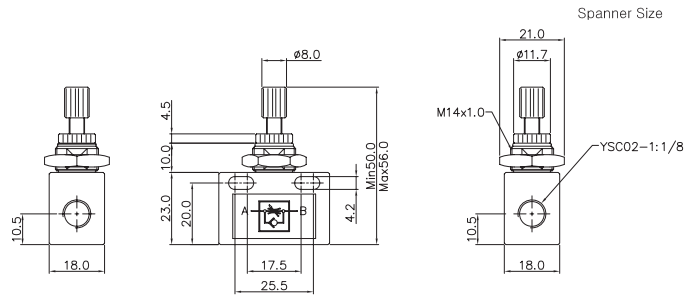

Pipe Type Speed Controller  
Thread- 1/4

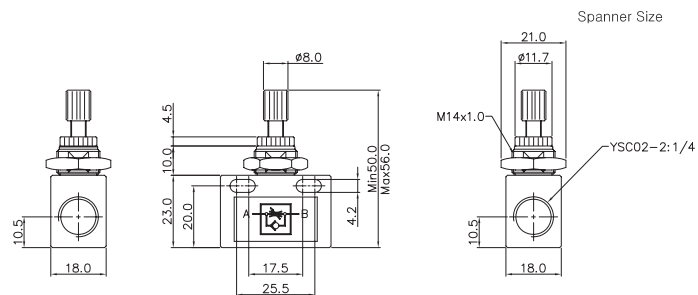

PANEL HOLE

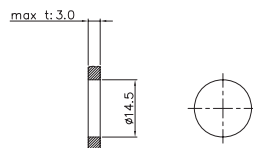

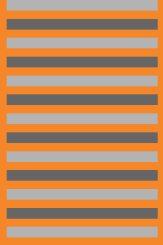

# Air Silencer Series

- M5, PT 1/8, 1/4, 3/8, 1/2
- Space Economy Type
- Long Life Time

## SPECIFICATION

### METAL SILENCER

Type	PORT SIZE	WEIGHT (g)	DIAMETER			
	PT		A	B	C	D
ASS 1000	M5	2	4	18	7	7
ASS 2000	1/8	6	7	24	8	11
ASS 4000	1/4	17	8	32	10.5	15
ASS 5000	3/8	28	10	39	12	19
ASS 6000	1/2	35	14	44	15	22

### PLASTIC SILENCER

Type	PORT SIZE	WEIGHT (g)	DIAMETER			
	PT		A	B	C	D
AS 2000	1/8	5	40	16	14	7
AS 4000	1/4	14	65	21	20	10
AS 5000	3/8	22	85	25	22	13
AS 6000	1/2	32	95	26	26	14

#### The Material of Parts

- Metal Silencer
- Plastic Silencer
- Body : Copper
- Body, Cap : POM
- Element : Powder
- Resin Element

※ The specification on each item can be amended without any prenotice to improve a performance.  
 ※ The specification on each item can be different from actual specification.

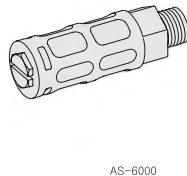
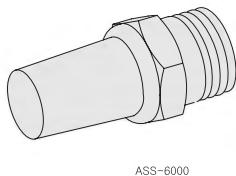
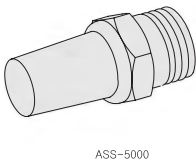
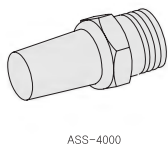
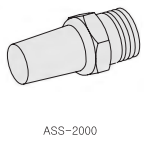
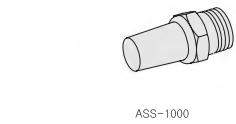

## ORDERING NO.

**ASS - 1000**

#### Silencer Type

ASS:  
Metal Silencer

AS:  
Plastic Silencer

#### Connection Size

1000	M5×0.8
2000	PT 1/8
4000	PT 1/4
5000	PT 3/8
6000	PT 1/2



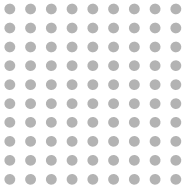

**Air Silencer Series**

**M5, 1/8, 1/4, 3/8, 1/2**

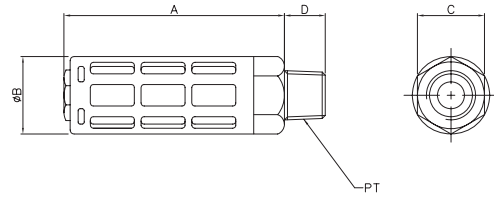
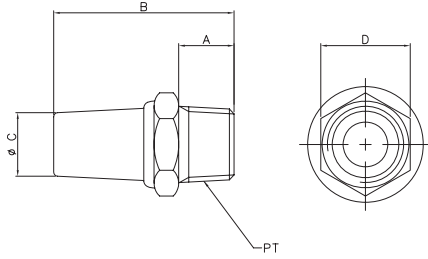

MODEL NO.	PORT SIZE	WEIGHT (g)	DIAMETER			
	PT		A	B	C	D
ASS 1000	M5	2	4	18	7	7
ASS 2000	1/8	6	7	24	8	11
ASS 4000	1/4	17	8	32	10,5	15
ASS 5000	3/8	28	10	39	12	19
ASS 6000	1/2	35	14	44	15	22

MODEL NO.	PORT SIZE	WEIGHT (g)	DIAMETER			
	PT		A	φB	C	D
AS 2000	1/8	5	40	16	14	7
AS 4000	1/4	14	65	21	20	10
AS 5000	3/8	22	85	25	22	13
AS 6000	1/2	32	95	26	26	14

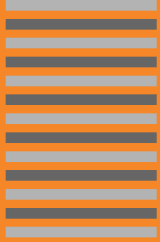

# YCT Series

Air Hydro Converter

- Usage Pressure 3~7bar
- Guaranteed Internal Pressure 10.5bar

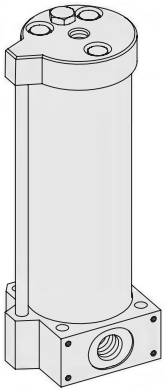

YCT 63x100

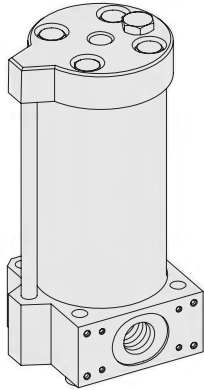

YCT 100x100

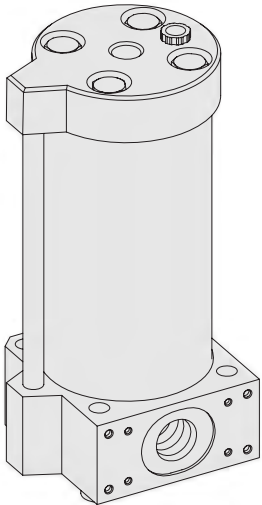

YCT 160x100

## SPECIFICATION

Usage Pressure	3~7bar
Guaranteed Internal Pressure	10.5bar
Ambient & Fluid Temp.	5~50°C
Fluid	Tubin Oil, Hydercting Diameter(40~100cst)

### The Material of Parts

- Base : Die-Cast Aluminium
- Tube : Aluminium Extruding
- Indicator Tube : Polycarbonate
- Float : Bubble Resin
- Tie Rod : Carbon Iron
- Nut Part : STS304

\* The specification on each item can be amended without any prenotice to improve a performance.  
 \* The specification on each item can be different from actual specification.

## ORDERING NO.

**YCT 63 - 100**

Diameter of Converter

63	63mm
100	100mm
160	160mm

Standard Effective Stroke(Str)

	50	100	150	200	250	300	350	400	500	600	700	800
63	○	○	○	○	○	○	○	○	○	×	×	×
100	×	○	○	○	○	○	○	○	○	○	×	×
160	×	×	×	○	○	○	○	○	○	○	○	○

\*Except to the above stroke statements, stroke design can be according to a quotation.

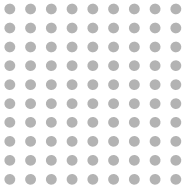

# Air Hydro Converter

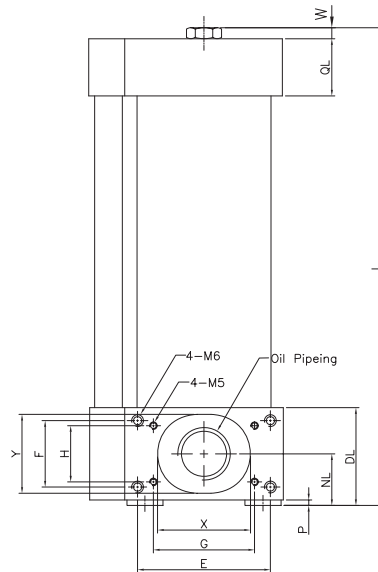
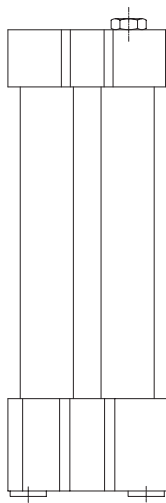
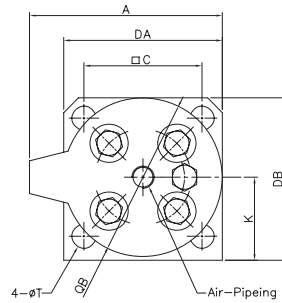

MODEL NO.\ITEM	AIR PIPE (PT)	OIL PIPE (PT)	A	C	DA	DB	DL	E
YCT 63	3/8	3/4	104	64	86	89	53	72
YCT 100	1/2	1	139	92	117	124	61	100
YCT 160	3/4	1 1/4	202	144	180	183	59	100

MODEL NO.\ITEM	F	G	H	K	NL	P	QB	QL	ø T	W	X	Y
YCT 63	36	72	36	45	28	3	86	31	11	6	35	35
YCT 100	40	72	36	65	33	5	118	32	13	6	53	45
YCT 160	40	72	36	93	29	0	180	48	18	6	44	44

### L' Dimension

MODEL NO.\STROKE	50	100	150	200	250	300	350	400	500	600	700	800
YCT 63	224	294	344	394	444	494	544	594	694	-	-	-
YCT 100	-	304	354	404	454	504	554	604	704	804	-	-
YCT 160	-	-	-	414	464	514	564	614	714	814	914	1014

# Booster Series

Direct Compressed Type  
Precompressed Type

■ Heavy Pressure Rate - 11 : 1  
25 : 1

■ Overflowing Oil Gauge  
70cm<sup>3</sup> (70cc)

Direct Compressed Type  
YNBH3-40 (11:1)  
YNBH3-60 (25:1)

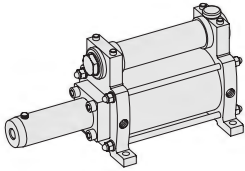

Precompressed Type  
YNPH3-40 (11:1)  
YNPH3-60 (25:1)

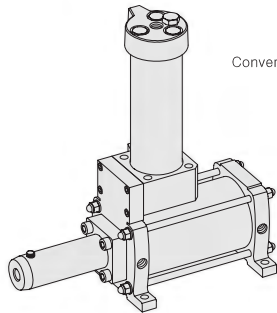

Converter is Optional

## SPECIFICATION

ITEM	SERIES	YNBH3-40	YNBH3-60
		YNPH3-40	YNPH3-60
Heavy Pressure Rate		11 : 1	25 : 1
Overflowing Oil Gauge		70cm <sup>3</sup> (70cc)	70cm <sup>3</sup> (70cc)
Overflowing Oil Pressure at the Time of Application Maximum air Pressure Temperature		77kgf/cm <sup>2</sup>	175kgf/cm <sup>2</sup>
Ambient & Fluid Temp.		5~60°C (41~140°F)	
Operation Oil		Cosmomiter 10(cosmo gasolin), Tough spendux oil(made in Julkwang Tongsan Co.)	
Air Pressure Department	Fluid	Air	
	Oil-Feeding	Not Require	
	Pressure	3~7bar	
	Oil	Tubin oil, Oil Equivalent to ISO VG 32#	
Weight(direct pressure)		8.0kgf	10.0kgf

### The Material of Parts

- Rod Cover : Die-Cast Aluminium
- Tie Rod : Carbon Iron
- Head Cover : Die-Cast Aluminium
- Hex Nut : Carbon Iron
- Tube : Aluminium Extruding

\* The specification on each item can be amended without any prenotice to improve a performance.  
\* The specification on each item can be different from actual specification.

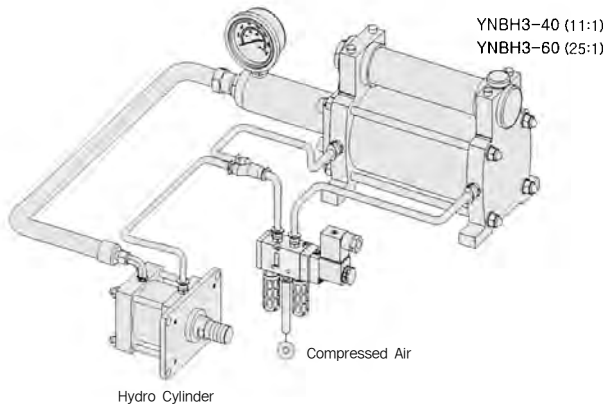

Hydro Cylinder

Compressed Air

YNBH3-40 (11:1)  
YNBH3-60 (25:1)

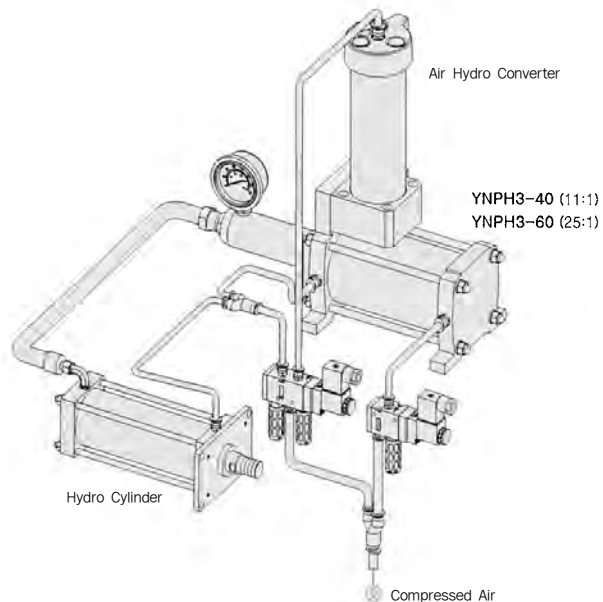

Hydro Cylinder

Air Hydro Converter

YNPH3-40 (11:1)  
YNPH3-60 (25:1)

Compressed Air

Direct Compressed Type

Precompressed Type

## ORDERING NO.

**YNBH 3 - 40 - 70**

Booster Series

YNBH3	Direct Compressed Type
YNPH3	Precompressed Type

Heavy Pressure Rate

40	(11:1)
60	(25:1)

Overflowing

70	70CC
100	100CC

# Booster Cylinder

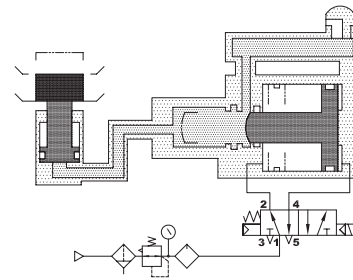
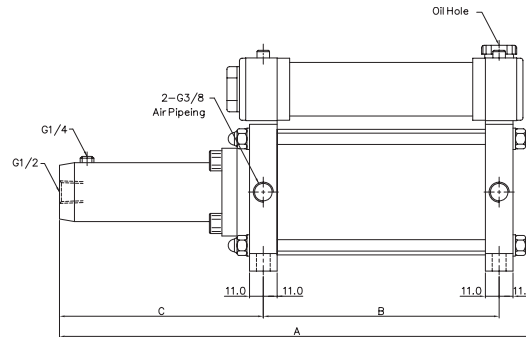
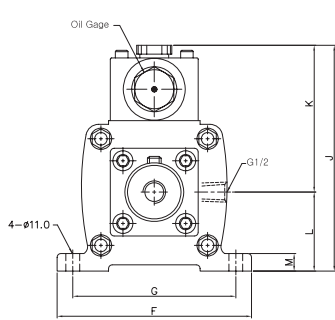
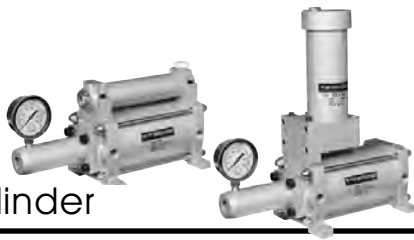

MODEL NO.	A	B	C	F	G	J	K	L	M
YNBH3-40-70	378	188	162.5	155	130	180	120	60	14
YNBH3-40-100	478	238	212.5						
YNBH3-60-70	378	188	162.5	225	190	227	137	90	16
YNBH3-60-100	478	238	212.5						

## Precompressed Type

MODEL NO.	A	B	C	F	G	J	K	L	M
YNPH3-40-70	378	188	162.5	155	130	196	136	60	14
YNPH3-40-100	478	238	212.5						
YNPH3-60-70	378	188	162.5	225	190	245	156	90	16
YNPH3-60-100	478	238	212.5						

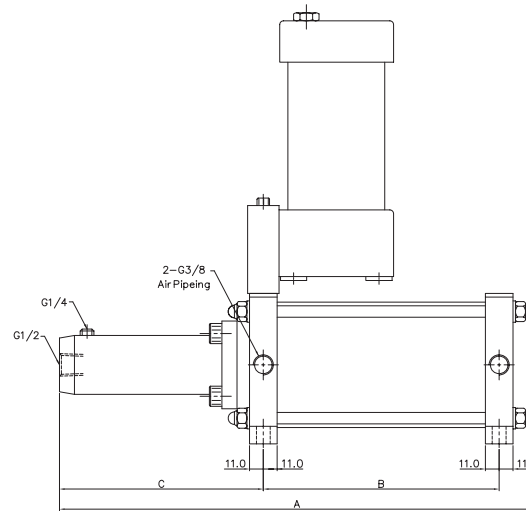
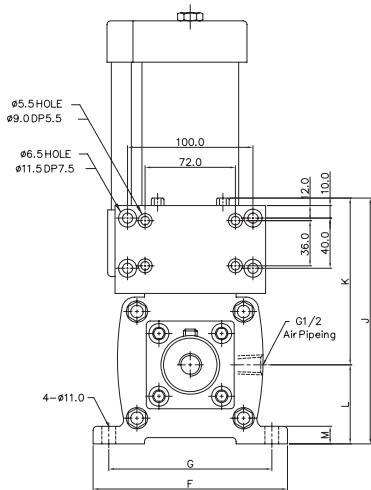

### ▶ Ending stroke

After finished work, compressor of oil cylinder has been restored to air pressure by converting valve, and all the stroke is returned original state, then is prepared to travel stroke.

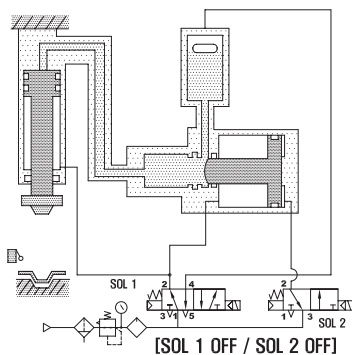

### ▶ Precompressed Travelling stroke

By using compressor, high compressed oil should be travelled to the hydraulic to get output.

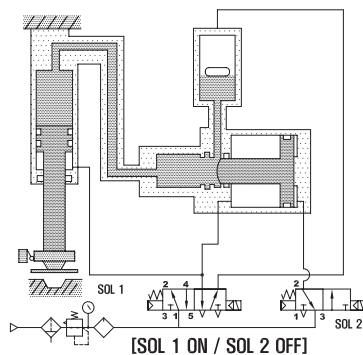

### ▶ Travelling stroke

By using common converter it has been changed from "low-compressed air pressure" to "oil pressure" at the time of 1:1 pressure.

